



Sitronix

ST2604B

PRELIMINARY

8 BIT Integrated Microcontroller with 512K Bytes ROM

Notice: Sitronix Technology Corp. reserves the right to change the contents in this document without prior notice. This is not a final specification. Some parameters are subject to change.

1. FEATURES

- **Totally static 8-bit CPU**
- **ROM: 512K x 8-bit**
- **RAM: 3.5K x 8-bit**
- **Stack: Up to 128-level deep**
- **Operation voltage: 2.4V ~ 3.6V**
- **Operation frequency:**
 - 3.0Mhz@2.4V(Min.)
 - 4.0Mhz@2.7V(Min.)
- **LCD Drives**
 - COM: 36 outputs. Eight shared with one output port
 - SEG: 64 outputs. Shared with 3 I/O ports and memory bus signals.
- **One 8x8 Signed Multiplier**
- **Low Voltage Reset (LVR)**
 - Two levels by code option
- **Low Voltage Detector (LVD)**
 - Programmable 4 levels
 - System power or external battery level can be detected.
- **Programmable Watchdog Timer (WDT)**
- **Memory interface to ROM, RAM, Flash**
- **Memory configuration**
 - Three kinds of banks for program, data and interrupt
 - 12-bit bank registers support up to 44M bytes
 - Six programmable chip-selects with 4 modes
 - Maximum single device of 16M bytes
- **General-Purpose I/O (GPIO) ports**
 - Up to 55 bit programmable CMOS I/Os
 - 39 shared with LCD drives
 - 8 open drain output pins shared with LCD COMs
 - Hardware de-bounce option for Port-A
 - Bit programmable pull-up for input pins
 - Pull-up/down and open-drain/CMOS control for Port-C
- **Timer/Counter**
 - Four 12-bit timers.
 - One 8-bit base timer
 - Seven fixed base timers
- **Three clocking outputs**
 - Clock sources including Timer0/1, baud rate generator
- **Eleven prioritized interrupts with dedicated exception vectors**
 - External interrupt (edge triggered)
 - PortA interrupt (transition triggered)
 - LCD buffer interrupt
 - Base timer interrupt
 - Timer0~3 interrupts (x4)
 - SPI interrupts (x2)
 - UART interrupts (x2)
- **Dual clock sources with warm-up timer**
 - Low frequency crystal oscillator (OSC) ...32768 Hz
 - High frequency resistor or crystal/resonator oscillator (OSC) selected by pin option 455K~4M Hz
- **Direct Memory Access (DMA)**
 - Block-to-Block transfer
 - Block to Single port
- **LCD Power Management**
 - DC-DC converter with 8-level output control
 - LC driving voltage regulator with 16-level control
 - 1/4, 1/5, 1/6 bias options with 4 voltage followers
- **LCD Driver**
 - 32x28~64x36 resolution, maximum 2304 dots
 - Clock source from OSC/OSCX.
 - Internal bias resistors(1/4, 1/5, 1/6 bias).
- **LCD Controller (LCDC)**
 - Software programmable display size up to 160X160
 - B/W, Hardware 4/16 gray levels with 5-bit palette
 - Support 1-/4-/8-bit LCD data bus
 - Share system memory with display buffer and with no loss of the CPU time
 - LCD buffer extension function to combine both internal and external RAM for larger display
 - Diverse functions including virtual screen, panning, scrolling, contrast control and alternating signal generator
- **Programmable Sound Generator (PSG)**
 - Four channels with three playing modes:
 - 9-bit ADPCM, 8-bit PCM and 8-bit melody
 - One 16-byte buffer and 6-bit volume control per channel
 - Wavetable melody support
 - Two dedicated PWM outputs for direct driving
 - One 12-bit current DAC
- **Universal Asynchronous Receiver/Transmitter (UART)**
 - Full-duplex operation
 - Baud rate generator with one digital PLL
 - Standard baud rates of 600 bps to 115.2 kbps
 - Both transmitter and receiver buffers supported
 - Direct glueless support of IrDA physical layer protocol
 - Two sets of I/Os (TX,RX) for two independent devices
- **Serial Peripheral Interface (SPI)**
 - Master and slave modes
 - Five serial signals including enable and data-ready
 - Both transmitter and receiver buffers supported
 - Programmable data length from 7-bit to 16-bit
- **Three power down modes**
 - WAI0 mode
 - WAI1 mode
 - STP mode

- Vlcd/LVD trimming fuse function:
 - Vlcd default voltage variation trimming.
 - 4-level LVD voltage variation trimming.

2. BLOCK DIAGRAM

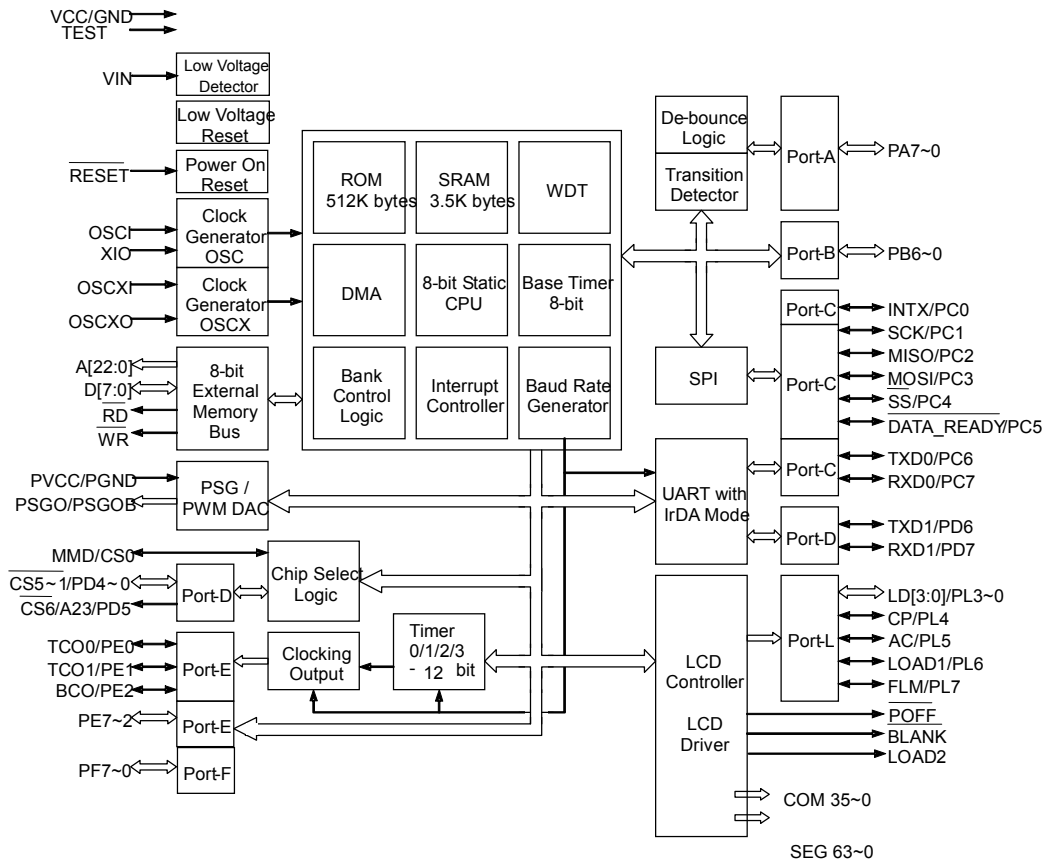

Figure 2-1 ST2604B Block Diagram

3. GENERAL DESCRIPTION

The ST2604B is a 8-bit integrated microcontroller designed with CMOS silicon gate technology. The true static CPU core, power down modes and dual oscillators design makes the ST2604B suitable for power saving and long battery life designs. The ST2604B integrates various logic to support functions on-chip which are needed by system designers.

The ST2604B features the capacity of memory access of maximum 44M bytes and DMA function for fast memory transfer. Six chip-select pins are equipped for direct connection to external ROM, SRAM, Flash memory or other devices. The maximum size for a single external memory device can be 16M bytes.

The ST2604B has 55 I/Os grouped into 6 ports. They are Port-A ~ Port-F and Port-L, where the Port-F is 8 open drain output pins shared with LCD COMs. Each I/O pins can be programmed to input or output individually. Port-C inputs have both pull-up and pull-down options. The other input pins have only pull-up options. In the case of output mode, Port-C outputs have open-drain type and CMOS type options; while the other ports are fixed at CMOS type. The Port-A and Port-B are designed for keyboard scan function. The Port-A inputs are further equipped with de-bounce and transition triggered interrupt function. The Port-B/C/D/E/L are shared with other system functions. All the properties of I/O pins are still programmable when they are configured to be other special functional signals. This enlarges the flexibility of the usage of the functional signals.

The ability of driving large LCD panels, up to 160x160, and hardware gray-level support rich the display information and the diversity of contents as well. By the patented sharing mechanism design of internal memory, the LCD display function can be done without the need of external display RAM. The variable LCD buffer design also makes it feasible to use small internal display RAM as the buffer of large-sized display. User may free major internal RAM for computing or temporary access while keeping the display content. The clock of LCD (LCDCK) is not only sourced from main-frequency (OSC), it can also be sourced by OSCX (32KHz crystal) to make current consumption to be minimum.

The ST2604B equips serial communication ports, one UART and one SPI, to perform different communications, ex.: RS-232 and IrDA, with system components or other products such as PC, Notebook, and popular PDA. Three clocking outputs can

produce synthesized PWM signals or high frequency carrier for IR remote control. This helps products become more useful in our daily life.

The built-in four-channel PSG are designed to generate key tone, melody, voice, and speech. Two dedicated pins with large driving capacity can drive a buzzer/speaker directly.

The ST2604B has a Low Voltage Detector (LVD) for power management usage. The status of internal or external power can be detected and reported to the management software.

Power bouncing during power-on is a major problem when designing a reliable system. The ST2604B equips a Low Voltage Reset function to keep the whole system in reset status when power is low. After the power returns to normal level, the system may recover its original states and keeps working correctly.

With these integrated functions inside, the ST2604B single chip microcontroller is a right solution for PDA, translator, databank and other consumer products.

The block diagram of ST2604B is shown in the above figure.

4. SIGNAL DESCRIPTIONS

Signal Function Groups

Function Group	Pad No.	Designation	Description
Power		VCC , PVCC, AVCC	VCC: Power supply for system AVCC: Power supply for LCD function PVCC: Power supply for PSGO and PSGOB
Ground		GND , PGND	GND: System power ground PGND: Power ground for PSGO and PSGOB
System control		$\overline{\text{RESET}}$, TEST, MMD/ $\overline{\text{CS0}}$	$\overline{\text{RESET}}$: Active low system reset signal input TEST: Leave this pin open when normal operation MMD/$\overline{\text{CS0}}$: Memory modes selection pin Normal mode: Enable internal ROM. MMD/ $\overline{\text{CS0}}$ is connected to GND. Emulation mode: Disable internal ROM. MMD/ $\overline{\text{CS0}}$ is connected to the chip-select pin of external ROM. During reset period, the MMD/ $\overline{\text{CS0}}$ is an internally pulled-up input pin. After reset cycles, MMD/ $\overline{\text{CS0}}$ is changed to be an output pin. It will output signal $\overline{\text{CS0}}$.
Clock		XIO,OSCI OSC XO,OSC XI ,	High frequency oscillator (OSC) mode selected by code-option Crystal mode: One crystal or resonator should be connected between OSCI and XIO Resistor oscillator mode: One resistor should be connected between OSCI and VCC OSC XI, OSC XO: Connect one 32768Hz crystal between these two pins when using low frequency oscillator
External memory bus signals / LCD drivers		$\overline{\text{WR}}$ / SEG9, $\overline{\text{RD}}$ / SEG8	External memory R/W control signals / LCD Segment drivers
		A[22:0]/SEG32~SEG10	External memory address bus / LCD Segment drivers
		D[7:0]/SEG7~SEG0	External memory data bus / LCD Segment drivers
PSG/PWM DAC		PSGO, PSGOB	PSG outputs. Connect to one buzzer or speaker
Keyboard scan signal (return line)		PA7~0	I/O port A
GPIO / LCD drivers		PB7~0/SEG63~SEG56	I/O port B / LCD Segment drivers
Chip selects / LCD drivers		CS5 ~ 1/PD4~0 / SEG37~SEG33, $\overline{\text{CS6}}$ /A23/PD5 /SEG38	I/O port D and chip-select outputs / LCD Segment drivers
UART		RXD0/PC7,TXD0/PC6, RXD1/PD7/SEG40,TXD1/ PD6/SEG39	UART signals and I/Os / LCD Segment drivers
SPI		$\overline{\text{DATA_READY}}$ /PC5 , SS/PC4 , SDO/PC3 , SDI/PC2 , SCK/PC1	SPI signals and I/Os

Signal Function Groups (continued)

Function Group	Pad No.	Designation	Description
External clock/signal interrupt		INTX/PC0	External interrupt inputs
Clocking output		BCO/PE2/SEG66 , TCO1/PE1/SEG65 , TCO0/PE0/SEG64	Clocking outputs / LCD Segment drivers
GPIO / LCD drivers		PE7~3/SEG71~SEG67	I/O port E/ LCD Segment drivers
LCD control signals (for controller mode)		BLANK/COM0, POFF/COM1, FLM/COM2, LOAD1/COM3, LOAD2/COM4, AC/COM5,CP/COM6, EIO/COM7, LD7~LD0/COM15/COM8	LCD control signals
LCD voltage source		Vout, Vlcd, V1, V2, V3, V4	LCD voltage sources
LCD voltage booster		C1+, C1-, C2+, C2-	Connect a 0.1 uF between C1+ and C1-, C2+ and C2- repectively.
Low Voltage Detector		VIN	Analog input pin of Low Voltage Dector module

5. ELECTRICAL CHARACTERISTICS

Absolute Maximum Ratings

DC Supply Voltage	-0.3V to +4.5V
Operating Ambient Temperature	-10°C to +60°C
Storage Temperature	-10°C to +125°C

***Note:** Stresses above those listed under "Absolute Maximum Ratings" may cause permanent damage to the device. All the ranges are stress ratings only. Functional operation of this device at these or any other conditions above those indicated in the operational sections of this specification is not implied or intended. Exposed to the absolute maximum rating conditions for extended periods may affect device reliability.

DC Electrical Characteristics

Standard operation conditions: VCC = 3.0V, GND = 0V, TA = 25°C, OSC = 4M Hz, unless otherwise specified

Parameter	Symbol	Min.	Typ.	Max.	Unit	Condition
Operating Voltage	VCC	2.4	3.0	3.6	V	Fosc = 3MHz
		2.7	3.0	3.6	V	Fosc = 4MHz
Operating Frequency	F ₁	-	-	3	MHz	VCC = 2.4V ~ 3.6V
Operating Frequency	F ₂	-	-	4	MHz	VCC = 2.7 ~ 3.6V
Operating Current	I _{OP}		2.5	3	mA	All I/O port are input and pull-up, execute NOP instruction, LCDC on
Standby Current	I _{SB0}		450	550	μA	All I/O port are input and pull-up, OSCX on, LCDC off (WAIT0 mode)
Standby Current	I _{SB1}		3.5	5	μA	All I/O port are input and pull-up, OSCX on, LCDC off (WAIT1 mode)
Standby Current	I _{SB2}		0.5	1	μA	All I/O port are input and pull-up, OSCX off, LCDC off (WAIT1 mode)
Standby Current	I _{SB3}		100	130	μA	LCD on, LCDCK=32Kz, Wait0, no panel
Input High Voltage	V _{IH}	0.7Vcc		Vcc+0.3	V	Port-C/D/E/L
		0.85Vcc			V	RESET
Input Low Voltage	V _{IL}	GND-0.3		0.3Vcc	V	Port-C/D/E/L
					0.15Vcc	V
Pull-up resistance	R _{IH}		150		KΩ	Port-C/D/E/L (input Voltage=0.7VCC)
Output high voltage	V _{OH1}	0.7Vcc			V	Port-C/D/L (I _{OH} = -6mA)
Output low voltage	V _{OL1}			0.3Vcc	V	Port-C/D/E/L (I _{OL} = 9mA)
Output high voltage	V _{OH2}	0.7Vcc			V	PSG, I _{OH} = -35mA.
Output low voltage	V _{OL2}			0.3Vcc	V	PSG, I _{OL} = 65mA.
DAC current						Maximum of I = 3mA
Low Voltage Detector current	I _{LVR}		30	60	μA	Total LVD current consumption
Vlcd variation		-3%		+3%		
INT LVD variation		-4%		+4%		
EXT LVD variation		-4%		+4%		

AC Electrical Characteristics

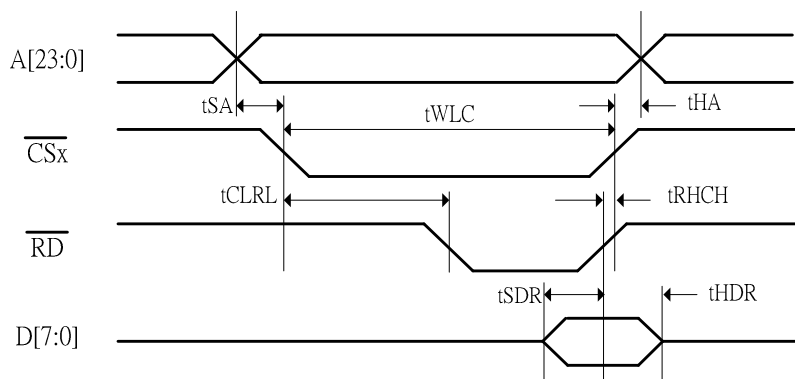

External Read Timing Diagram

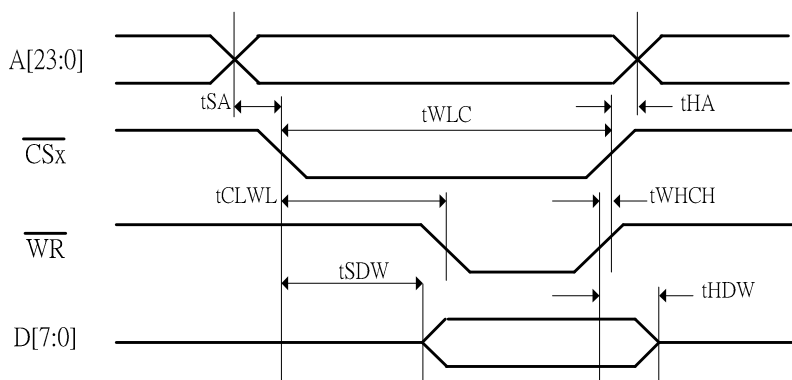

External Write Timing Diagram

1. Timing parameters for 0 and 0

Standard operation conditions: VCC = 3.0V, GND = 0V, TA = 25°C

Symbol	Characteristic	Rating			Unit
		Min.	Typ.	Max.	
tSA	Address setup time	—	—	10	ns
tHA	Address hold time	0	—	—	ns
tWLC	CS “L” pulse width	166	—	—	ns
tCLWL	CS asserted to WR asserted	—	1/2 tWLC	—	ns
tWHCH	CS negated after WR is negated	10	—	—	ns
tSDW	CS asserted to data-out is valid	—	1/2 tWLC	—	ns
tHDW	Data-out hold time after WR is negated	20	—	—	ns
tCLRL	CS asserted to RD asserted	—	1/2 tWLC	—	ns
tRHCH	CS negated after RD is negated	10	—	—	ns
tSDR	Data-in valid before RD is negated	30	—	—	ns
tHDR	Data-in hold time after RD is negated	10	—	—	ns
tR	Signal rise time	—	20	—	ns
tF	Signal fall time	—	10	—	ns

6. APPLICATION CIRCUITS

ST2604B Application Circuit 1

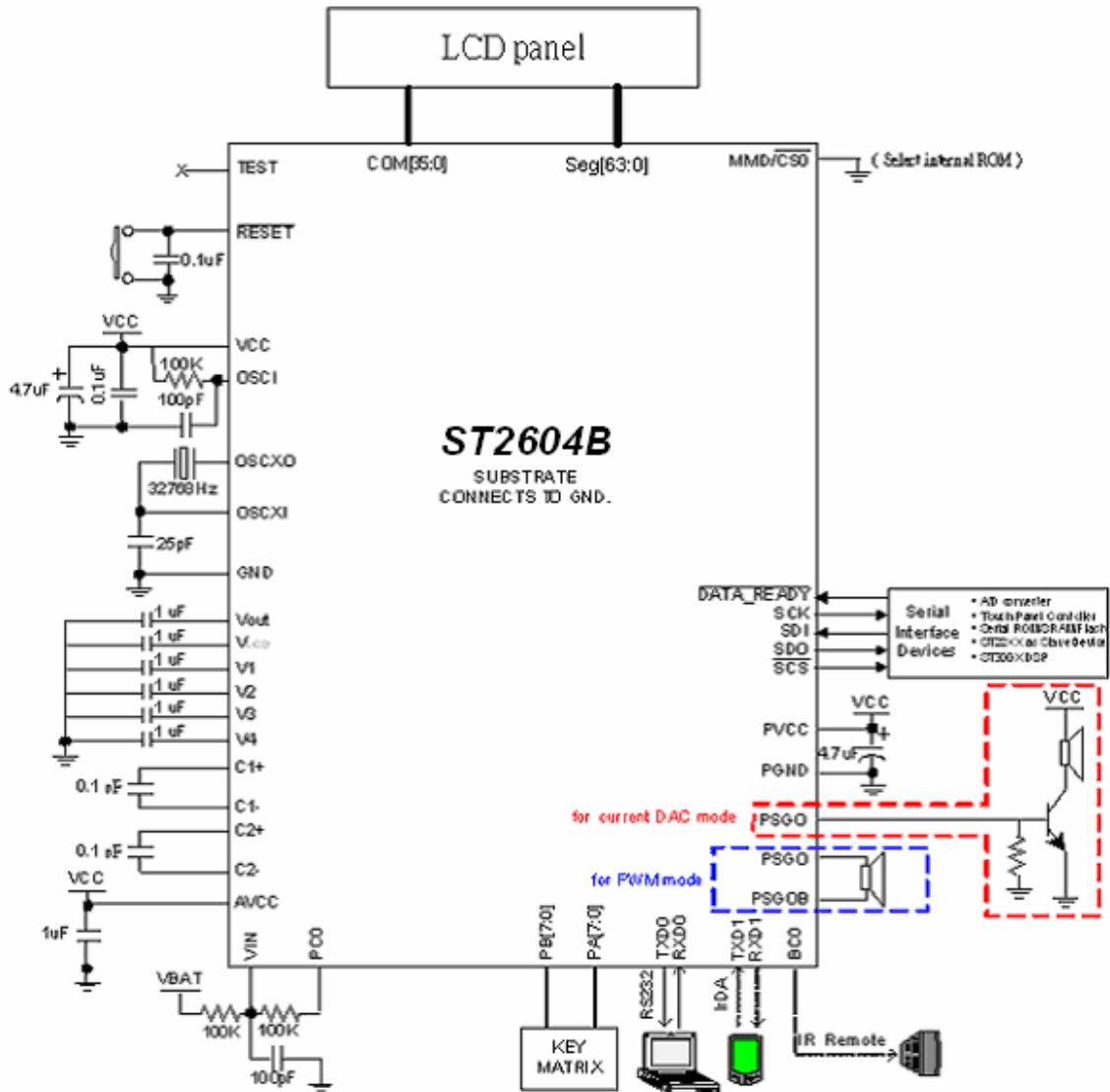

ST2604B Application Circuit 2

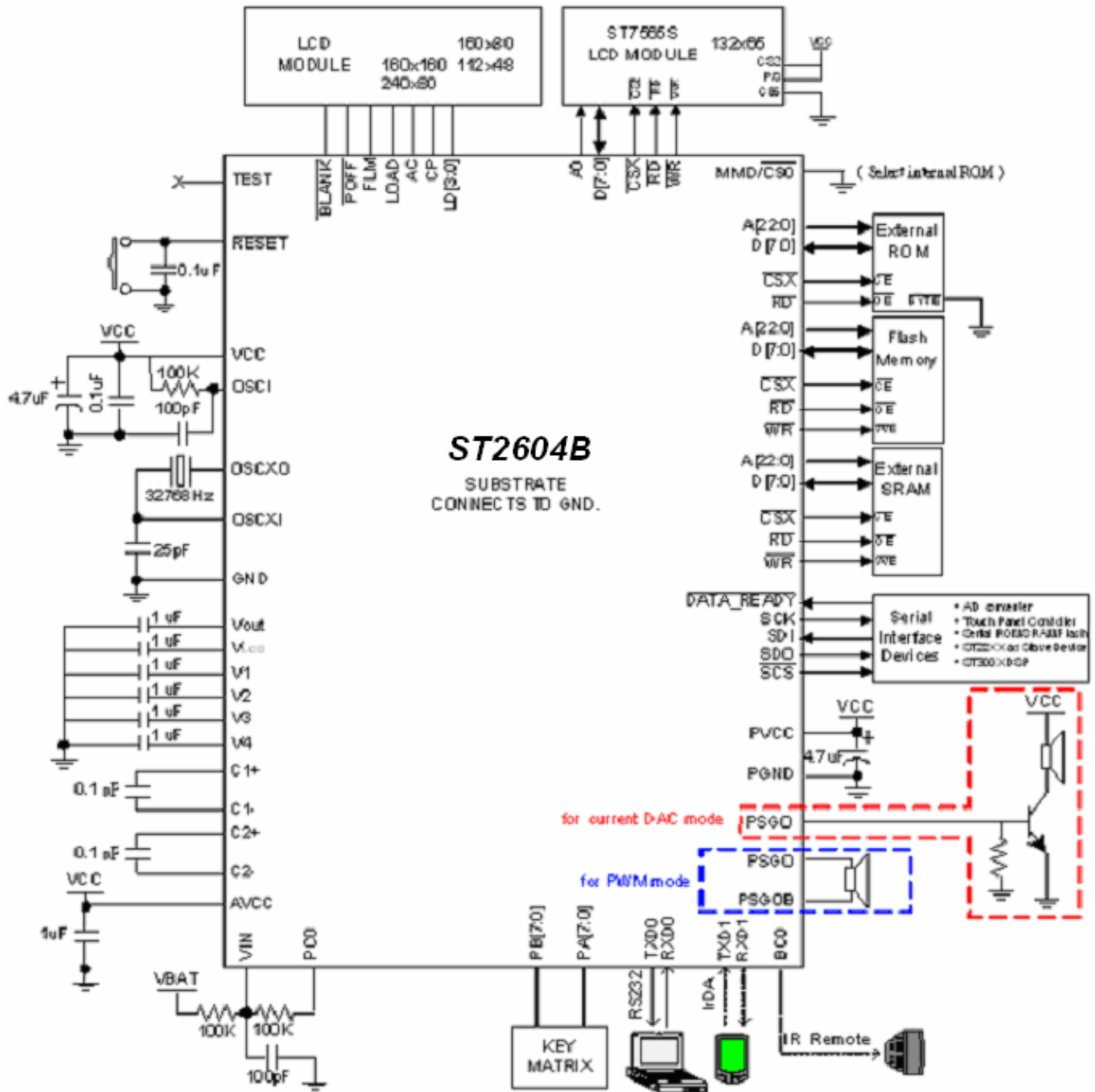

ST2604B+ST8008+ST8009 Application Circuit

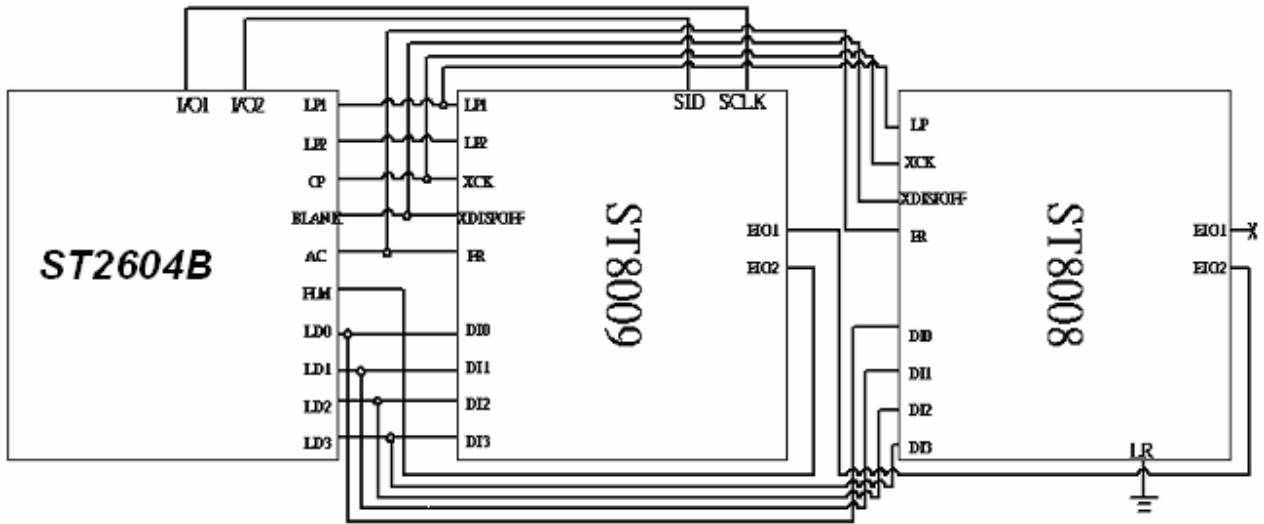

Note:

LR pin of ST8008 is connected to GND.

L/R bit of ST8009 is configured as low by "interface control selection" instruction

7. FEATURE COMPARISON OF ST2600B SERIES

Part Number	ST2608B	ST2604B	ST2602B	ST2601B
ROM	1M Byte	512K Byte	256K Byte	128K Byte
RAM	5K Byte	3.5K Byte	2.5K Byte	2.5K Byte
Built-in LCD Driver	36 COMs X 72 SEGs	36 COMs X 64 SEGs	36 COMs X 56 SEGs	36 COMs X 56 SEGs
Driving LCD with ext. driver	~9000 dots (16 gray) ~36000 dots (mono)	~6000 dots (16 gray) ~24000 dots (mono)	~4000 dots (16 gray) ~16000 dots (mono)	~2500 dots (16 gray) ~10000 dots (mono)
Dedicated I/O	24 (PA, PC, PL)	16 (PA, PC)	8 (PC)	8 (PC)
LCD-Shared I/O	32 (PB, PD, PE, PF)	39 (PB[6:0], PD, PE, PL, PF)	31 (PD, PE[6:0], PL, PF)	31 (PD, PE[6:0], PL, PF)
LCD gray level	16 gray levels			
PSG / volume-control	4-channel wavetable / 64 levels			
DAC	9-bit PWM, 12-bit current DAC			
Low voltage detector	4 levels			
Low voltage reset	Yes			
Watchdog timer	Yes			
Serial interface	UART, SPI, IrDA			

The above information is the exclusive intellectual property of Sitronix Technology Corp. and shall not be disclosed, distributed or reproduced without permission from Sitronix. Sitronix Technology Corp. reserves the right to change this document without prior notice and makes no warranty for any errors which may appear in this document. Sitronix products are not intended for use in life support, critical care, medical, safety equipment, or similar applications where products failure could result in injury, or loss of life, or personal or physical harm, or any military or defense application, or any governmental procurement to which special terms or provisions may apply.