

Sitronix

ST2016A

16K 8-bit Single Chip Microcontroller

Notice: Sitronix Technology Corp. reserves the right to change the contents in this document without prior notice. This is not a final specification. Some parameters are subject to change.

1. FEATURES

- 8-bit static pipeline CPU
- ROM: 16K x 8 bits
- RAM: 192 x 8 bits
- Operation voltage : 2.4V ~ 3.6V
- 24 CMOS Bi-directional bit programmable I/O pins
 - Twenty (Port-A high nibble & Port-B/C) are shared with LCD drives
- 6 Output pins (Four are shared with LCD common and two are shared with PSG)
- 2 Input pins (code option: Shared with OSCX)
- Hardware debounce option for input port
- Bit programmable PULL-UP for input port
- Timer/Counter :
 - One 8-bit timer / 16-bit event counter
 - One 8-bit BASE timer
- Five powerful interrupt sources :
 - External interrupt (edge trigger)
 - TIMER1 interrupt
 - BASE timer interrupt
 - PORTA[7~0] interrupt (transition trigger)
 - DAC reload interrupt
- 32-level deep stack
- Dual clock source :
 - OSCX: Crystal oscillator: 32768Hz
 - OSC: RC oscillator 500K ~ 4M Hz
 - CPU clock 250K ~ 2M Hz
- Build-in oscillator with warm-up timer
- LCD controller driver:
 - 16 level contrast control
 - 320 (8x40) dots (1/8 duty, 1/4 bias, programmable)
 - 160 (4x40) dots (1/4 duty, 1/3 bias, programmable)
 - Two clock source options: RC and resonator oscillator
 - Keyboard scan function supported on 20 shared segment drives
 - Internal bias resistors(1/4 bias & 1/3 bias) with 32 level driving strength control
- Programmable Sound Generator (PSG) includes :
 - Tone generator
 - Sound effect generator
 - 16 level volume control
 - Digital DAC for speech / tone
- Three power down modes :
 - WAI0 mode
 - WAI1 mode
 - STP mode

2. GENERAL DESCRIPTION

ST2016A is a low-cost, high-performance, fully static, 8-bit microcontroller designed with CMOS silicon gate technology. It comes with 8-bit pipeline CPU core, SRAM, timer, LCD driver, I/O port, PSG and mask program ROM. A

build-in dual oscillator is specially integrated to enhance chip performance. For business equipment and consumer applications. Such as watch, calculator, and LCD game , ST2016A is definitely a perfect solution for implementation.

3. BLOCK DIAGRAM

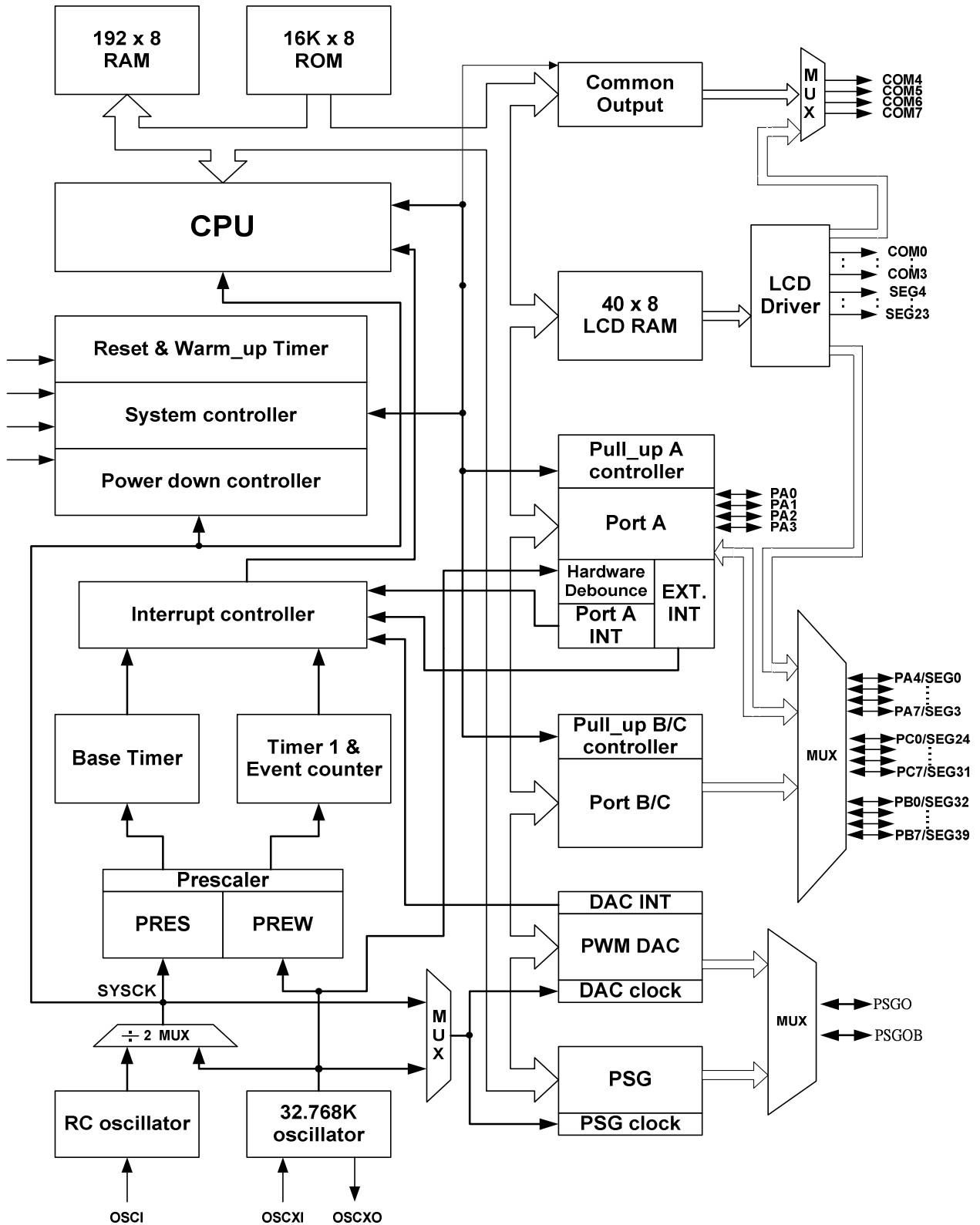

5. Bonding Information

Chip Size: 1700 X 1740 μm

- The chip substrate should be wired to GND pin.

Unit: μm

PAD #	NAME	PAD CENTER		PAD #	NAME	PAD CENTER	
		X	Y			X	Y
1	SEG11	57.5	57.5	31	COM1	1642.5	1682.5
2	SEG10	167.50	57.5	32	COM0	1522.50	1682.5
3	SEG9	277.50	57.5	33	PB7/SEG39	1412.50	1682.5
4	SEG8	382.50	57.5	34	PB6/SEG38	1307.50	1682.5
5	SEG7	486.25	57.5	35	PB5/SEG37	1203.75	1682.5
6	SEG6	588.75	57.5	36	PB4/SEG36	1101.25	1682.5
7	SEG5	691.25	57.5	37	PB3/SEG35	998.75	1682.5
8	SEG4	793.75	57.5	38	PB2/SEG34	896.25	1682.5
9	PA7/SEG3	896.25	57.5	39	PB1/SEG33	793.75	1682.5
10	PA6/SEG2	998.75	57.5	40	PB0/SEG32	691.25	1682.5
11	PA5/SEG1	1101.25	57.5	41	PC7/SEG31	588.75	1682.5
12	PA4/SEG0	1203.75	57.5	42	PC6/SEG30	486.25	1682.5
13	PA3	1307.5	57.5	43	PC5/SEG29	382.50	1682.5
14	PA2	1412.5	57.5	44	PC4/SEG28	277.50	1682.5
15	PA1	1522.5	57.5	45	PC3/SEG27	167.50	1682.5
16	PA0/INTX	1642.5	57.5	46	PC2/SEG26	57.5	1682.5
17	OSCXO/PD1	1642.5	175.35	47	PC1/SEG25	57.5	1568.70
18	OSCXI/PD0	1642.5	291.25	48	PC0/SEG24	57.5	1455.65
19	RESET	1642.5	405.25	49	SEG23	57.5	1347.35
20	OSCI	1642.5	518.25	50	SEG22	57.5	1240.30
21	VDD	1642.5	630.25	51	SEG21	57.5	1134.50
22	PSGOB	1642.5	741.25	52	SEG20	57.5	1028.70
23	PSGO	1642.5	843.75	53	SEG19	57.5	922.90
24	GND	1642.5	946.25	54	SEG18	57.5	817.10
25	COM7	1642.5	1048.75	55	SEG17	57.5	711.30
26	COM6	1642.5	1151.25	56	SEG16	57.5	605.50
27	COM5	1642.5	1253.75	57	SEG15	57.5	499.70
28	COM4	1642.5	1357.50	58	SEG14	57.5	392.65
29	COM3	1642.5	1462.50	59	SEG13	57.5	284.35
30	COM2	1642.5	1572.50	60	SEG12	57.5	171.30

6. PAD DESCRIPTION

Designation	Pad #	Type	Description
SEG0/PA4 ~ SEG3/PA7	12 ~ 9	O I/O	LCD Segment output Port-A bit programmable I/O
SEG4 ~ SEG23	8 ~ 1 60 ~ 49	O	LCD Segment output
SEG24/PC0 ~ SEG31/PC7	48 ~ 41	O I/O	LCD Segment output Port-C bit programmable I/O
SEG32/PB0 ~ SEG39/PB7	40 ~ 33	O I/O	LCD Segment output Port-B bit programmable I/O
COM 0 – 3	32 ~ 29	O	LCD Common output
COM 4 - 7	28 ~ 25	O O	LCD Common output Output port
RESET	19	I	Pad reset input (HIGH Active)
GND	24	P	Ground Input and chip substrate
PA0/INTX	16	I/O I I I	Port-A bit programmable I/O Edge-trigger Interrupt. Transition-trigger Interrupt Programmable Timer1 clock source
PA 1-7	15 ~ 13	I/O I	Port-A bit programmable I/O Transition-trigger Interrupt
PSGO,PSGOB	23,22	O	PSG/DAC Output
V _{DD}	21	P	Power supply
OSCXI/PD0	18	I I	OSC input pin. For 32768Hz crystal Port-D input
OSCXO/PD1	17	O I	OSC output pin. For 32768Hz crystal Port-D input
OSCI	20	I	OSC input pin. toward to external resistor

Legend: I = input, O = output, I/O = input/output, P = power.

7. CPU

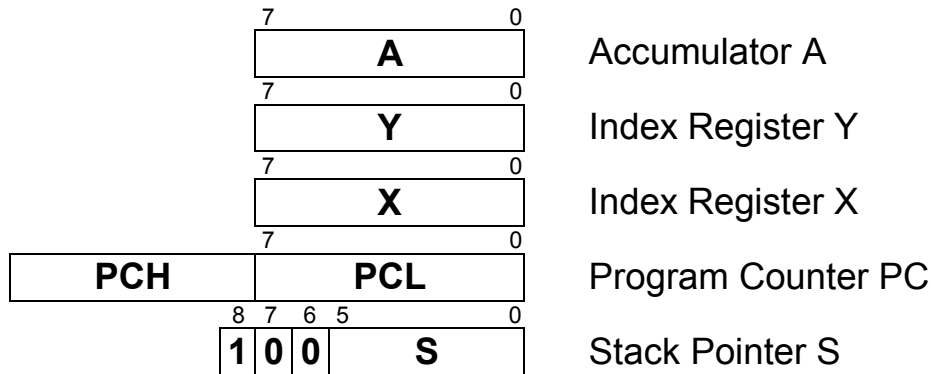

CPU REGISTER MODEL

7.1 Accumulator (A)

The accumulator is a general purpose 8-bit register which stores the results of most arithmetic and logic operations. In addition, the accumulator usually contains one of the two data words used in these operations.

7.2 Index Registers (X,Y)

There are two 8-bit Index Registers (X and Y) which may be used to count program steps or to provide an index value to be used in generating an effective address. When executing an instruction which specifies indexed addressing, the CPU fetches the OP code and the base address, and modifies the address by adding the index register to it prior to performing the desired operation. Pre or post-indexing of indirect addresses is possible.

7.3 Stack Pointer (S)

The stack Pointer is an 8-bit register which is used to control the addressing of the variable-length stack. Its range from 100H to 13FH total for 64 bytes (32-level deep). The stack pointer is automatically incremented and decremented under control of the microprocessor to perform stack

Accumulator A

Index Register Y

Index Register X

Program Counter PC

Stack Pointer S

manipulations under direction of either the program or interrupts (IRQ). The stack allows simple implementation of nested subroutines and multiple level interrupts. The stack pointer is initialized by the user's software.

7.4 Program Counter (PC)

The 16-bit Program Counter register provides the address which step the microprocessor through sequential program instructions. Each time the microprocessor fetches an instruction from program memory, the lower byte of the program counter (PCL) is placed on the low-order bits of the address bus and the higher byte of the program counter (PCH) is placed on the high-order 8 bits. The counter is incremented each time an instruction or data is fetched from program memory.

7.5 Status Register (P)

The 8-bit Processor Status Register contains seven status flags. Some of the flags are controlled by the program, others may be controlled both by the program and the CPU. The instruction set contains a member of conditional branch instructions which are designed to allow testing of these flags.

TABLE 7-1: STATUS REGISTER (P)

Bit 7	Bit 6	Bit 5	Bit 4	Bit 3	Bit 2	Bit 1	Bit 0
N	V	1	B	D	I	Z	C
<p>Bit 7: N : Signed flag by arithmetic 1 = Negative 0 = Positive</p> <p>Bit 6: V : Overflow of signed Arithmetic flag 1 = Negative 0 = Positive</p> <p>Bit 4: B : BRK interrupt flag * 1 = BRK interrupt occur 0 = Non BRK interrupt occur</p> <p>Bit 3: D : Decimal mode flag 1 = Decimal mode 0 = Binary mode</p> <p>Bit 2: I : Interrupt disable flag 1 = Interrupt disable 0 = Interrupt enable</p> <p>Bit 1: Z : Zero flag 1 = Zero 0 = Non zero</p> <p>Bit 0: C : Carry flag 1 = Carry 0 = Non carry</p>							

8. MEMORY CONFIGURATION

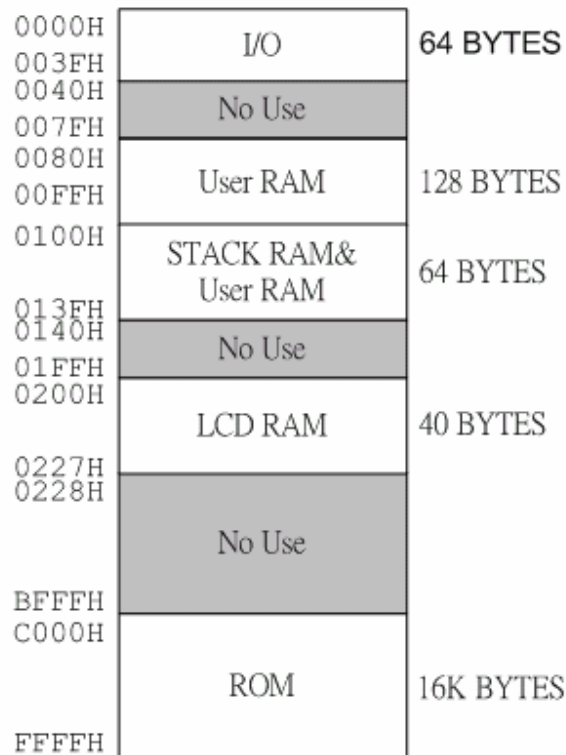

8.1 ROM (\$C000~\$FFFF)

The ST2016A has 16K bytes ROM used for program, data and vector address.

Vector address mapping :

\$FFFE	Software BRK operation vector..
\$FFFC	RESET vector.
\$FFFA	Reserved.
\$FFF8	INTX (PA0) edge interrupter.
\$FFF6	Reload DAC data interrupter.
\$FFF4	Reserved.
\$FFF2	Timer1 interrupter.
\$FFF0	PORTA transition interrupter.
\$FFEE	Base Timer interrupter.

8.2 RAM

The RAM mapping includes Control Registers, Data RAM, Stack RAM and LCD RAM.

TABLE 8-2: CONTROL REGISTERS (\$0000~\$003E)

Address	Name	R/W	Bit 7	Bit 6	Bit 5	Bit 4	Bit 3	Bit 2	Bit 1	Bit 0	Default
\$000	PA	R/W	PA[7]	PA[6]	PA[5]	PA[4]	PA[3]	PA[2]	PA[1]	PA[0]	1111 1111
\$001	PB	R/W	PB[7]	PB[6]	PB[5]	PB[4]	PB[3]	PB[2]	PB[1]	PB[0]	1111 1111
\$002	PC	R/W	PC[7]	PC[6]	PC[5]	PC[4]	PC[3]	PC[2]	PC[1]	PC[0]	1111 1111
\$003	PD	R/W	-	-	-	-	-	-	PD[1]	PD[0]	---- -- 11
\$008	PCA	R/W	PCA[7]	PCA[6]	PCA[5]	PCA[4]	PCA[3]	PCA[2]	PCA[1]	PCA[0]	0000 0000
\$009	PCB	R/W	PCB[7]	PCB[6]	PCB[5]	PCB[4]	PCB[3]	PCB[2]	PCB[1]	PCB[0]	0000 0000
\$00A	PCC	R/W	PCC[7]	PCC[6]	PCC[5]	PCC[4]	PCC[3]	PCC[2]	PCC[1]	PCC[0]	0000 0000
\$00E	PAK	R/W	PAK[7]	PAK[6]	PAK[5]	PAK[4]	PAK[3]	PAK[2]	PAK[1]	PAK[0]	0000 0000
\$00F	PMCR	R/W	PULL	PDBN	INTEG	-	-	-	-	-	100 - ----
\$010	PSG0L	R/W	PSG0[7]	PSG0[6]	PSG0[5]	PSG0[4]	PSG0[3]	PSG0[2]	PSG0[1]	PSG0[0]	0000 0000
\$011	PSG0H	R/W	-	-	-	-	PSG0[11]	PSG0[10]	PSG0[9]	PSG0[8]	---- 0000
\$012	PSG1L	R/W	PSG1[7]	PSG1[6]	PSG1[5]	PSG1[4]	PSG1[3]	PSG1[2]	PSG1[1]	PSG1[0]	0000 0000
\$013	PSG1H	R/W	-	-	-	-	PSG1[11]	PSG1[10]	PSG1[9]	PSG1[8]	---- 0000
\$014	DAC	R/W	DAC[7]	DAC[6]	DAC[5]	DAC[4]	DAC[3]	DAC[2]	DAC[1]	DAC[0]	0000 0000
\$015	PSGC2	R/W	-	-	-	-	PSGOD	PSGOBD	PSGOE	PSGOBE	---- 1111
\$016	PSGC	R/W	-	PCK[2]	PCK[1]	PCK[0]	PRBS	C1EN	C0EN	DACE=0	-000 0000
		R/W	-	PCK[2]	PCK[1]	PCK[0]	DMD[1]	DMD[0]	INH	DACE=1	-000 0000
\$017	VOL	R/W	VOL1[3]	VOL1[2]	VOL1[1]	VOL1[0]	VOL0[3]	VOL0[2]	VOL0[1]	VOL0[0]	0000 0000
\$020	LCK	R/W	DRV[4]	DRV[3]	DRV[2]	DRV[1]	DRV[0]	LCK[2]	LCK[1]	LCK[0]	0000 0100
\$021	BTM	R/W	-	-	-	-	BTM[3]	BTM[2]	BTM[1]	BTM[0]	---- 0000
\$023	PRS	R	PRS[7]	PRS[6]	PRS[5]	PRS[4]	PRS[3]	PRS[2]	PRS[1]	PRS[0]	1111 1111
		W	SRES	SENA	SENT	-	-	-	-	-	-
\$026	T1M	R/W	-	-	-	T1M[4]	T1M[3]	T1M[2]	T1M[1]	T1M[0]	--0 0000
\$027	T1C	R/W	T1C[7]	T1C[6]	T1C[5]	T1C[4]	T1C[3]	T1C[2]	T1C[1]	T1C[0]	0000 0000
\$030	SYS	R/W	XSEL	OSTP	XSTP	TEST	WSKP	WAIT	-	-	0000 00--
\$039	LSEL	R/W	LSEL[7]	-	-	LSEL[4]	LSEL[3]	LSEL[2]	LSEL[1]	LSEL[0]	1--1 1111
\$03A	LCTL	R/W	LPWR	BLANK	DUTY	SCAN	CTR[3]	CTR[2]	CTR[1]	CTR[0]	1000 0000
\$03B	COM	R/W	COM[7]	COM[6]	COM[5]	COM[4]	-	-	-	-	0000 ----
\$03C	IREQ	R/W	-	-	IRBT	IRPT	IRT1	-	IRDAC	IRX	???? ????
\$03E	IENA	R/W	-	-	IEBT	IEPT	IET1	-	IEDAC	IEX	--00 0-00

- Note: 1. Some addresses of I/O area, \$3~\$7, \$B~\$E, \$15, \$18~\$1F, \$22, \$24~\$25, \$28~\$2F, \$31~\$39, \$3D,\$3F, are no used.
 2. User should never use undefined addresses and bits.
 3. Do not use Bit instructions for write-only registers, such as RMBx, SMBx
 4. E.V.B 's RAM Power On Initial Value are Same as Real Chip.

8.2.2 DATA RAM (\$0080~\$00FF)

DATA RAM are organized in 128 bytes.

8.2.3 STACK RAM (\$0100~\$013F)

STACK RAM are organized in 64 bytes. It provides for a maximum of 32-level subroutine stacks And can be used as data memory.

8.2.4 LCD RAM (\$0200~\$0227)

Resident LCD-RAM, accessible through write and read instructions, are organized in 40 bytes for 40x8 LCD display. Note that this area can also be used as data memory.

9. INTERRUPTS

TABLE 9-3: PREDEFINED VECTORS FOR INTERRUPT

Name	Signal	Vector address	Priority	Comment
BRK	Internal	\$FFFF,\$FFFE	8	Software BRK operation vector
RESET	External	\$FFFD,\$FFFC	1	RESET vector
-	-	\$FFFB,\$FFFA	-	Reserved
INTX	External	\$FFF9,\$FFF8	2	PA0 edge interrupt
DAC	Internal	\$FFF7,\$FFF6	3	Reload DAC data interrupt
-	-	\$FFF5,\$FFF4	-	Reserved
T1	INT/EXT	\$FFF3,\$FFF2	4	Timer1 interrupt
PT	External	\$FFF1,\$FFF0	5	Port-A transition interrupt
BT	Internal	\$FEEF,\$FEE	6	Base Timer interrupt

9.1 Interrupt description

Brk

Instruction 'BRK' will cause software interrupt when interrupt disable flag (I) is cleared. Hardware will push 'PC', 'P' Register to stack and set interrupt disable flag (I). Program counter then will be loaded with the BRK vector from locations \$7FFE and \$7FFF.

RESET

A positive transition of RESET pin will then cause an initialization sequence to begin. After the system has been operating, a high on this line of a least two clock cycles will cease ST2016A activity. When a positive edge is detected, there is an initialization sequence lasting six clock cycles. Then the interrupt mask flag is set, the decimal mode is cleared and the program counter will be loaded with the restart vector from locations \$FFFC (low byte) and \$FFFD (high byte). This is the start location for program control. This input should be low in normal operation.

INTX interrupt

The IRX (INTX interrupt request) flag will be set while INTX edge signal occurs. The INTX interrupt will be active once IEX (INTX interrupt enable) is set, and interrupt mask flag is cleared. Hardware will push 'PC', 'P' Register to stack and set interrupt mask flag (I). Program counter will be loaded with the INTX vector from locations \$FFF8 and \$FFF9.

DAC interrupt

The IRDAC (DAC interrupt request) flag will be set while reload signal of DAC occurs. Then the DAC interrupt will be executed when IEDAC (DAC interrupt enable) is set, and

interrupt mask flag is cleared. Hardware will push 'PC', 'P' Register to stack and set interrupt mask flag (I). Program counter will be loaded with the DAC vector from locations \$FFF6 and \$FFF7.

T1 interrupt

The IRT1 (TIMER1 interrupt request) flag will be set while T1 overflows. With IET1 (TIMER1 interrupt enable) being set, the T1 interrupt will be executed, and interrupt mask flag will be cleared. Hardware will push 'PC', 'P' Register to stack and set interrupt mask flag (I). Program counter will be loaded with the T1 vector from locations \$FFF2 and \$FFF3.

PT interrupt

The IRPT (Port-A interrupt request) flag will be set while Port-A transition signal occurs. With IEPT (PT interrupt enable) being set, the PT interrupt will be executed, and interrupt mask flag will be cleared. Hardware will push 'PC', 'P' Register to stack and set interrupt mask flag (I). Program counter will be loaded with the PT vector from locations \$FFF0 and \$FFF1.

BT interrupt

The IRBT (Base timer interrupt request) flag will be set when Base Timer overflows. The BT interrupt will be executed once the IEBT (BT interrupt enable) is set and the interrupt mask flag is cleared. Hardware will push 'PC', 'P' Register to stack and set interrupt mask flag (I). Program counter will be loaded with the BT vector from locations \$FEEF and \$FEE.

9.2 Interrupt request clear

Interrupt request flag can be cleared by two methods. One is to write "0" to IENA, the other is to initiate the interrupt

service routine when interrupt occurs. Hardware will automatically clear the Interrupt flag.

TABLE 9-4: INTERRUPT REQUEST REGISTER (IREQ)

Address	Name	R/W	Bit 7	Bit 6	Bit 5	Bit 4	Bit 3	Bit 2	Bit 1	Bit 0	Default
\$03C	IREQ	R/W	-	-	IRBT	IRPT	IRT1	-	IRDAC	IRX	???? ????
<p>Bit 5: IRBT: Base Timer Interrupt Request bit 1 = Time base interrupt occurs 0 = Time base interrupt doesn't occur</p> <p>Bit 4: IRPT: Port-A Interrupt Request bit 1 = Port-A transition interrupt occurs 0 = Port-A transition interrupt doesn't occur</p> <p>Bit 3: IRT1: Timer1 Interrupt Request bit 1 = Timer1 overflow interrupt occurs 0 = Timer1 overflow interrupt doesn't occur</p> <p>Bit 1: IRDAC: DAC reload Interrupt Request bit 1 = DAC time out interrupt occurs 0 = DAC time out interrupt doesn't occur</p> <p>Bit 0: IRX: INTX Interrupt Request bit 1 = INTX edge interrupt occurs 0 = INTX edge interrupt doesn't occur</p>											

TABLE 9-5: INTERRUPT ENABLE REGISTER (IENA)

Address	Name	R/W	Bit 7	Bit 6	Bit 5	Bit 4	Bit 3	Bit 2	Bit 1	Bit 0	Default
\$03E	IENA	R/W	-	-	IEBT	IEPT	IET1	-	IEDAC	IEX	-- 00 0-00
<p>Bit 5: IEBT: Base Timer Interrupt Enable bit 1 = Time base interrupt enable 0 = Time base interrupt disable</p> <p>Bit 4: IEPT: Port-A Interrupt Enable bit 1 = Port-A transition interrupt enable 0 = Port-A transition interrupt disable</p> <p>Bit 3: IET1: Timer1 Interrupt Enable bit 1 = Timer1 overflow interrupt enable 0 = Timer1 overflow interrupt disable</p> <p>Bit 1: IEDAC: DAC reload Interrupt Enable bit 1 = DAC time out interrupt enable 0 = DAC time out interrupt disable</p> <p>Bit 0: IEX: INTX Interrupt Enable bit 1 = INTX edge interrupt enable 0 = INTX edge interrupt disable</p>											

10. I/O PORTS

ST2016A can supply total 24 GPIOs divided into three I/O ports, Port-A, Port-B, and Port-C. Besides I/O function, Port-B/C & Port-A's high nibble can also be used as LCD segment drives. For detail pin assignment, please refer to TABLE 10-6:

NOTE: all of unused input pins should be pulled up to minimize standby current

TABLE 10-6: I/O DESCRIPTION

PORT NAME	PAD NAME	PAD NUMBER	PIN TYPE	FEATURE
Port-A	PA0/INTX	16	I/O	Programmable input/output pin
	PA1	15	I/O	
	PA2	14	I/O	
	PA3	13	I/O	
	PA4/SEG0	12	I/O	
	PA5/SEG1	11	I/O	
	PA6/SEG2	10	I/O	
	PA7/SEG3	9	I/O	
Port-B	SEG32/PB0	40	I/O	Programmable input/output pin
	SEG33/PB1	39	I/O	
	SEG34/PB2	38	I/O	
	SEG35/PB3	37	I/O	
	SEG36/PB4	36	I/O	
	SEG37/PB5	35	I/O	
	SEG38/PB6	34	I/O	
	SEG39/PB7	33	I/O	
Port-C	SEG24/PC0	48	I/O	Programmable input/output pin
	SEG25/PC1	47	I/O	
	SEG26/PC2	46	I/O	
	SEG27/PC3	45	I/O	
	SEG28/PC4	44	I/O	
	SEG29/PC5	43	I/O	
	SEG30/PC6	42	I/O	
	SEG31/PC7	41	I/O	
COM[4~7]	COM4	28	O	Programmable output pin
	COM5	27	O	
	COM6	26	O	
	COM7	25	O	

10.2 PORT-A

Port-A is a bit-programmable bi-direction I/O port, which is controlled by PCA register. It also provides bit programmable pull-up resistor for each input pin. Two interrupts can be triggered by Port-A, de-bounced interrupt for keyboard scan and edge sensitive interrupt (PA0 only) for external event. Four of

these I/Os can change into LCD segment drives. LSEL[7] of control register LSEL specifies which of these I/Os are LCD drives (Please refer to 15.3.1.1 LCD Segment Number Selection Register (LSEL)).

TABLE 10-7: SUMMARY FOR PORT-A REGISTERS

Address	Name	R/W	Bit 7	Bit 6	Bit 5	Bit 4	Bit 3	Bit 2	Bit 1	Bit 0	Default
\$000	PA	R/W	PA[7]	PA[6]	PA[5]	PA[4]	PA[3]	PA[2]	PA[1]	PA[0]	1111 1111
\$008	PCA	R/W	PCA[7]	PCA[6]	PCA[5]	PCA[4]	PCA[3]	PCA[2]	PCA[1]	PCA[0]	0000 0000
\$00E	PAK	R/W	PAK[7]	PAK[6]	PAK[5]	PAK[4]	PAK[3]	PAK[2]	PAK[1]	PAK[0]	0000 0000
\$00F	PMCR	R/W	PULL	PDBN	INTEG	-	-	-	-	-	100 - - - - -
\$03C	IREQ	R/W	-	-	IRBT	IRPT	IRT1	-	IRDAC	IRX	???? ???? ?
\$03E	IENA	R/W	-	-	IEBT	IEPT	IET1	-	IEDAC	IEX	-- 00 0-00
\$039	LSEL	R/W	LSEL[7]	-	-	LSEL[4]	LSEL[3]	LSEL[2]	LSEL[1]	LSEL[0]	1 - -1 1111

10.2.1 PORT-A I/O control

Direction of Port-A is controlled by PCA. Every bit of PCA[7~0] is mapped to the I/O direction of PA[7~0]

correspondingly, with "1" for output mode, and "0" for input mode.

TABLE 10-8: PORT-A CONTROL REGISTER (PCA)

Address	Name	R/W	Bit 7	Bit 6	Bit 5	Bit 4	Bit 3	Bit 2	Bit 1	Bit 0	Default
\$008	PCA	R/W	PCA[7]	PCA[6]	PCA[5]	PCA[4]	PCA[3]	PCA[2]	PCA[1]	PCA[0]	0000 0000
Bit 7~0: PCA[7~0] : Port-A directional bits 1 = Output mode 0 = Input mode											

10.2.2 Port-A used as keyboard return line

When LCD Keyboard Awakening Pulses function is enabled (Please refer to 15.5 Keyboard-scan Function on LCD drives), the LCD waveform is always affected by Port-A signal if Port-A was used as keyboard return line and any key was being pressed. In order to reduce the effect from port-A, PAK

register must be set. The function will active when LCD on , LCD keyboard awakening pulses enable and **PAK[7~0]** is set to "1".

TABLE 10-9: Port-A used as keyboard return line selection

Address	Name	R/W	Bit 7	Bit 6	Bit 5	Bit 4	Bit 3	Bit 2	Bit 1	Bit 0	Default
\$00E	PAK	R/W	PAK[7]	PAK[6]	PAK[5]	PAK[4]	PAK[3]	PAK[2]	PAK[1]	PAK[0]	0000 0000
Bit 7~0: PAK[7~0] : 1 = Port-A used as keyboard return line. 0 = Port-A used as keyboard normal I/O.											

10.2.3 PORT-A PULL-UP OPTION

PORT-A contains pull-up MOS transistors controlled by software. When an I/O is used as an input. The ON/OFF of the pull-up MOS transistor will be controlled by port data register (PA) and the pull-up MOS will be enabled with "1"

for data bit and disable with "0" for data bit. The PULL control bit of PMCR controls the ON/OFF of all the pull-up MOS simultaneously. Please refer to the Figure 9-1.

FIGURE 10-1: Port-A Configuration Function Block Diagram

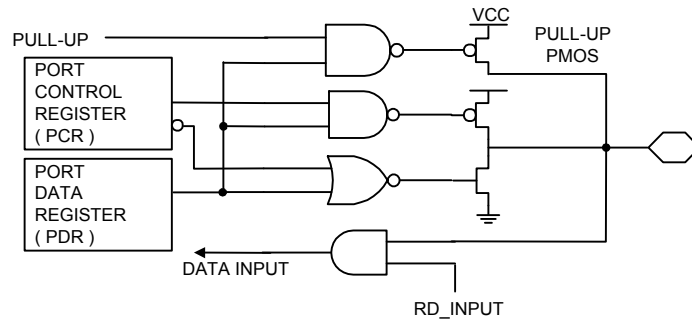

TABLE 10-10: PORT CONDITION CONTROL REGISTER (PMCR)

Address	Name	R/W	Bit 7	Bit 6	Bit 5	Bit 4	Bit 3	Bit 2	Bit 1	Bit 0	Default
\$00F	PMCR	R/W	PULL	PDBN	INTEG	-	-	-	-	-	100 - - - -

Bit 7: **PULL** : Enable all pull-up function bit
 1 = Enable pull-up function
 0 = Disable pull-up function

Bit 6: **PDBN** : Enable Port-A interrupt debounce bit
 1 = Debounce for Port-A interrupt
 0 = No debounce for Port-A interrupt

Bit 5: **INTEG** : INTX interrupt edge select bit
 1 = Rising edge
 0 = Falling edge

10.2.4 Port-A interrupt

Port-A, a programmable I/O, can be used as a port interrupt when it is in the input mode. Any edge transition of the Port-A input pin will generate an interrupt request. The last state of Port-A must be kept before I/O transition and this can be accomplished by reading Port-A.

When programmer enables INTX and PT interrupts, PA0 trigger occur. INTX and PT interrupts will therefore happen sequentially. Please refer to the Figure 9-2.

Operating Port-A interrupt step by step :

1. Set input mode.
2. Read Port-A.
3. Clear interrupt request flag (IRPT).
4. Set interrupt enable flag (IEPT).
5. Clear CPU interrupt disable flag (I).
6. Read Port-A before 'RTI' instruction in INT-Subroutine.

Example :

```

.
.
.
STZ    PCA           ;Set input mode.
LDA    #$FF
STA    PA           ;PA be PULL-UP.
LDA    PA           ;Keep last state.
RMB4   <IREQ       ;Clear IRQ flag.
SMB4   <IENA       ;Enable INT.
CLI
.
.

```

INT-SUBROUTINE

```

.
.
LDA    PA           ;Keep last state.
RTI

```

FIGURE 10-2: Port Interrupt Logic Diagram

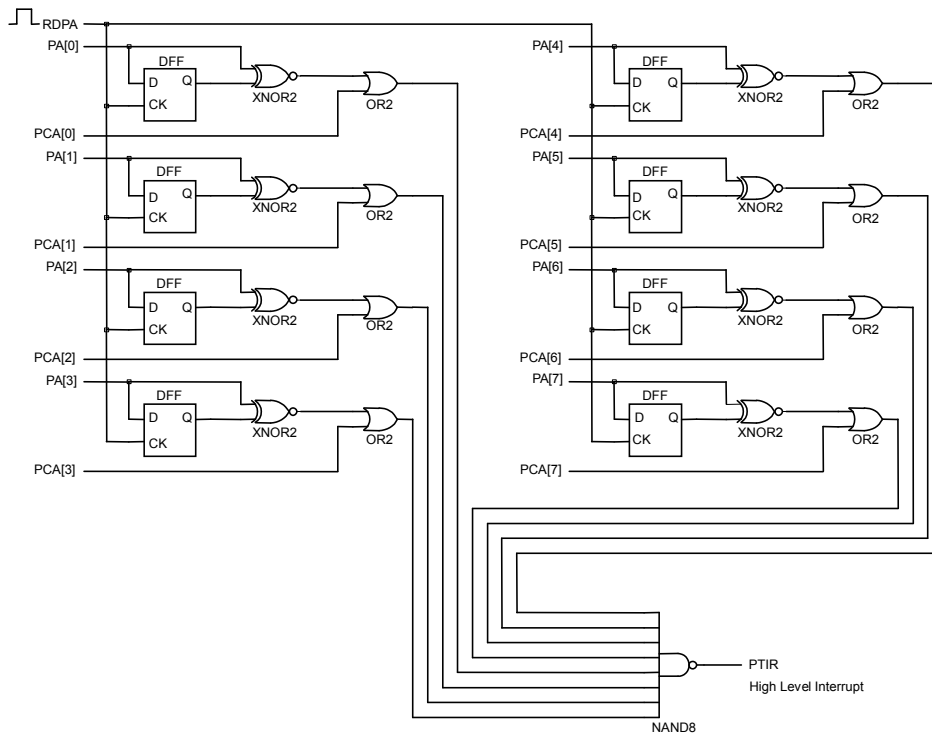

10.2.4.1 Port-A interrupt debounce

ST2016A has hardware debounce option for Port-A interrupt. The debounce will be enabled with "1" and disable with "0" for PDBN. The debounce will active when Port-A transition occurs, PDBN enable and **OSCX enable**.

The debounce time is **OSCX x 512 cycles(about 16 ms)**. Refer to the TABLE 9-10.

TABLE 10-11: PORT CONDITION CONTROL REGISTER (PMCR)

Address	Name	R/W	Bit 7	Bit 6	Bit 5	Bit 4	Bit 3	Bit 2	Bit 1	Bit 0	Default
\$00F	PMCR	R/W	PULL	PDBN	INTEG	-	-	-	-	-	100 - - - - -

Bit 6: **PDBN** : Enable Port-A interrupt debounce bit
 1 = Debounce for Port-A interrupt
 0 = No debounce for Port-A interrupt

10.2.5 PA0/INTX

PA0 can be used as an external interrupt input(INTX). Falling or Rising edge is controlled by INTEG(PMCR[5]) and the external interrupt is set up with "0" for falling edge and "1" for rising edge. Please refer to the Figure 9-3.

When programmer enables INTX and PT interrupts, PA0 trigger will occur. Both INTX and PT interrupts will happen sequentially. Please refer to the operating steps.

Operating INTX interrupt step by step :

1. Set PA0 pin into input mode. (PCA[0])
2. Select edge level. (INTEG)
3. Clear INTX interrupt request flag. (IRX)
4. Set INTX interrupt enable bits. (IEX)
5. Clear CPU interrupt mask flag (I).

Example :

```

.
.
.
RMB0 <PCA ;Set input mode.
SMB5 <PMCR ;Rising edge.
RMB0 <IREQ ;Clear IRQ flag.
SMB0 <IENA ;Enable INTX interrupt.
CLI
.
.
.
    
```

FIGURE 10-3: INTX Logic Diagram

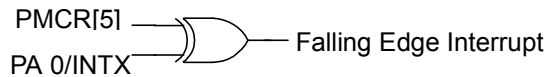

10.3 Port-B and Port-C

10.3.1 General Description

Port-B and Port-C are bit-programmable bi-direction I/O ports, controlled by PCB and PCC registers. There is also bit programmable pull-up resistor for each input pin. All of the 16 I/Os can change into LCD segment drives. Control register

LSEL specifies which of these I/Os are LCD drives(Please refer to 15.3.1.1 LCD Segment Number Selection Register (LSEL)).

TABLE 10-12: Summary of Port-B AND Port-C Registers

Address	Name	R/W	Bit 7	Bit 6	Bit 5	Bit 4	Bit 3	Bit 2	Bit 1	Bit 0	Default
\$001	PB	R/W	PB[7]	PB[6]	PB[5]	PB[4]	PB[3]	PB[2]	PB[1]	PB[0]	1111 1111
\$002	PC	R/W	PC[7]	PC[6]	PC[5]	PC[4]	PC[3]	PC[2]	PC[1]	PC[0]	1111 1111
\$009	PCB	R/W	PCB[7]	PCB[6]	PCB[5]	PCB[4]	PCB[3]	PCB[2]	PCB[1]	PCB[0]	0000 0000
\$00A	PCC	R/W	PCC[7]	PCC[6]	PCC[5]	PCC[4]	PCC[3]	PCC[2]	PCC[1]	PCC[0]	0000 0000
\$00F	PMCR	R/W	PULL	PDBN	INTEG	-	-	-	-	-	100 - - - -
\$039	LSEL	R/W	LSEL[7]	-	-	LSEL[4]	LSEL[3]	LSEL[2]	LSEL[1]	LSEL[0]	1 - - 1 1111

10.3.2 Input/Output Control

PCB/PCC controls the I/O direction of Port-B/C. Each bit of PCB[7~0]/PCC[7~0] controls the direction of one single bit of

Port-B/C respectively, with “1” for output mode, and “0” for input mode.

TABLE 10-13: PORT-B Control Register (PCB)

Address	Name	R/W	Bit 7	Bit 6	Bit 5	Bit 4	Bit 3	Bit 2	Bit 1	Bit 0	Default
\$009	PCB	R/W	PCB[7]	PCB[6]	PCB[5]	PCB[4]	PCB[3]	PCB[2]	PCB[1]	PCB[0]	0000 0000
Bit 7~0: PCB[7~0] : Port-B directional bits 1 = Output mode 0 = Input mode											

TABLE 10-14: PORT-C Control Register (PCC)

Address	Name	R/W	Bit 7	Bit 6	Bit 5	Bit 4	Bit 3	Bit 2	Bit 1	Bit 0	Default
\$00A	PCC	R/W	PCC[7]	PCC[6]	PCC[5]	PCC[4]	PCC[3]	PCC[2]	PCC[1]	PCC[0]	0000 0000
Bit 7~0: PCC[7~0] : Port-C directional bits 1 = Output mode 0 = Input mode											

10.3.3 Port-B and Port-C PULL-UP option

Port-B/C contains PMOS transistors of pull-up resistor controlled by software in bit-manner. In case of input direction, on/off of the pull-up PMOS transistor is controlled by the data wrote to data register, PB/PC. "1" is for enable

and "0" is for disable. Above all, whole pull-up control is by PULL bit of PMCR. Refer to FIGURE 10-4: for the block description.

FIGURE 10-4: Port-B and Port-C Block Diagram

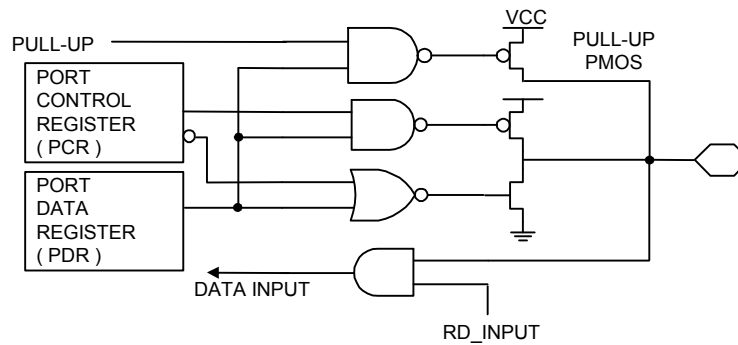

TABLE 10-15: Port Control Register (PMCR)

Address	Name	R/W	Bit 7	Bit 6	Bit 5	Bit 4	Bit 3	Bit 2	Bit 1	Bit 0	Default
\$00F	PMCR	R/W	PULL	PDBN	INTEG	-	-	-	-	-	100 - - - - -
Bit 7: PULL : Enable all pull-up functions bit 1 = Enable pull-up function 0 = Disable pull-up function											

10.4 PORT-D

Port-D only can be used as input. These two pins(PD0,PD1) are shared with OSCXI and OSCXO by one **code option**. The structure of input is different from Port-A/B/C. It has a

latch circuit to keep input value. Once low or high voltages are inputted, the circuit will latch "0" or "1" respectively. If the input pin is floating, it keeps the latest value.

FIGURE 10-5: Port-D latch input circuit

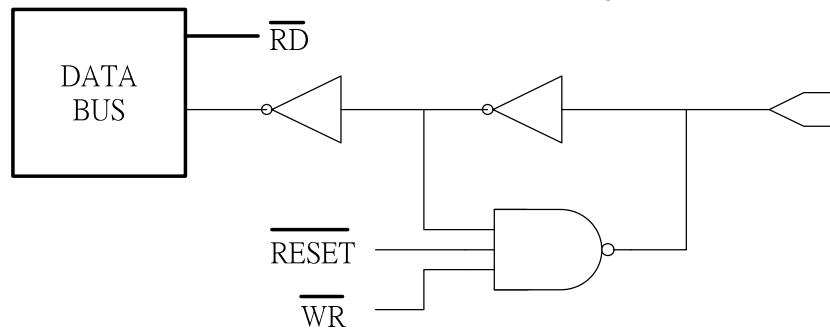

Address	Name	R/W	Bit 7	Bit 6	Bit 5	Bit 4	Bit 3	Bit 2	Bit 1	Bit 0	Default
\$03	PD	R/W	-	-	-	-	-	-	PD[1]	PD[0]	---- -- 11

Bit 1~0: **PD[1~0]** :
 . If the input pin is floating, it keeps the latest value.

10.5 COMMON-PORT

The COM4~COM7 can be used as LCD drivers or output ports. In output port mode, COM[7~4] will be map to COM7~COM4 output ports, which pin assignment will be

decided by Bit 5 of LCTL[5], Please refer to the following table.

TABLE 10-16: LCD CONTROL REGISTER (LCTL)

Address	Name	R/W	Bit 7	Bit 6	Bit 5	Bit 4	Bit 3	Bit 2	Bit 1	Bit 0	Default
\$03A	LCTL	R/W	LPWR	BLANK	DUTY	SCAN	CTR[3]	CTR[2]	CTR[1]	CTR[0]	1000 0000
Bit 5: DUTY : Common output selection bit 1 = 1/8 duty and COM4~COM7 used as LCD Common pins 0 = 1/4 duty and COM4~COM7 used as output pins											

TABLE 10-17: COMMON OUTPUT REGISTER (COM)

Address	Name	R/W	Bit 7	Bit 6	Bit 5	Bit 4	Bit 3	Bit 2	Bit 1	Bit 0	Default
\$03B	COM	R/W	COM[7]	COM[6]	COM[5]	COM[4]	-	-	-	-	0000 ----
Bit 4: COM[4] : COM4 scan output bit 1 = COM4 output =FLOATING 0 = COM4 output =LOW Bit 5: COM[5] : COM5 scan output bit 1 = COM5 output =FLOATING 0 = COM5 output =LOW Bit 6: COM[6] : COM6 scan output bit 1 = COM6 output =FLOATING 0 = COM6 output =LOW Bit 7: COM[7] : COM7 scan output bit 1 = COM7 output =FLOATING 0 = COM7 output =LOW											

11. Oscillator

ST2016A is with dual-clock system. Programmer can choose between OSC(RC) and OSCX(32.768k), or both as clock source through program. The system clock(SYSCK) also can be switched between OSC and OSCX. The OSC will be switch with "0" and OSCX will be switch with "1" for

XSEL. Whenever system clock be switch, the warm-up cycles are occur at the same time. That is confirm SYSCK really switched when read **XSEL** bit. LCD driver, Timer1, Base Timer can utilize these two clock sources as well.

TABLE 11-18: SYSTEM CONTROL REGISTER (SYS)

Address	Name	R/W	Bit 7	Bit 6	Bit 5	Bit 4	Bit 3	Bit 2	Bit 1	Bit 0	Default
\$030	SYS	R/W	XSEL	OSTP	XSTP	TEST	WSKP	WAIT	-	-	0000 00- -
<p>Bit 7: XSEL : SYS [XSEL] must be 0</p> <p>Bit 6: OSTP : OSC stop control bit 1 = Disable OSC 0 = Enable OSC</p> <p>Bit 5: XSTP : OSCX stop control bit 1 = Disable OSCX 0 = Enable OSCX</p> <p>Bit 4: TEST :Test bit, must be "0"</p> <p>Bit 3: WSKP : System warm-up control bit 1 = Warm-up to 16 oscillation cycles 0 = Warm-up to 256 oscillation cycles</p> <p>Bit 2: WAIT : WAI-0 / WAI-1mode select bit (Refer to POWER DOWN MODE) 1 = WAI instruction causes the chip to enter WAI-1 mode 0 = WAI instruction causes the chip to enter WAI-0 mode</p>											

Note:
The XSEL(SYS[7]) bit will show which real working mode is when it is read.

FIGURE 11-6: System Clock Diagram

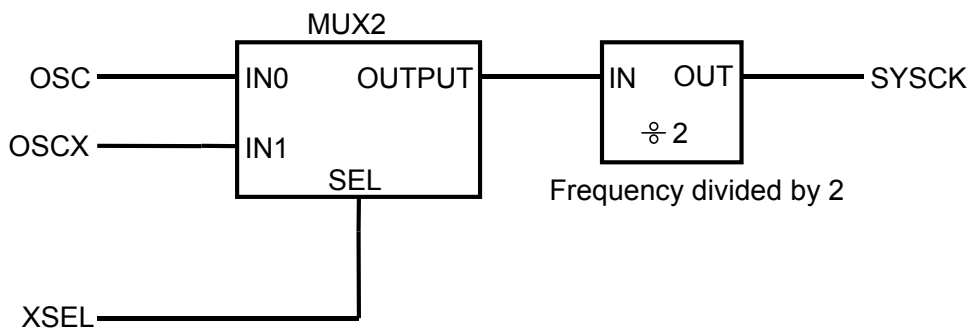

12. TIMER/EVENT COUNTER

The ST2016A has two timers: Base timer/Timer1, and two prescalers (PRES and PREW). There are two clock sources

for PRES and one clock source(OSCX) for PREW. Please refer to the following table:

TABLE 12-19: CLOCK SOURCE (TCLK) FOR PRES

SENT	Clock source(TCLK)	MODE
1	INTX	Event counter
0	SYSCK	Timer

TABLE 12-20: SUMMARY FOR TIMER REGISTERS

Address	Name	R/W	Bit 7	Bit 6	Bit 5	Bit 4	Bit 3	Bit 2	Bit 1	Bit 0	Default
\$021	BTM	R/W	-	-	-	-	BTM[3]	BTM[2]	BTM[1]	BTM[0]	---- 0000
\$023	PRS	R	PRS[7]	PRS[6]	PRS[5]	PRS[4]	PRS[3]	PRS[2]	PRS[1]	PRS[0]	1111 1111
		W	SRES	SENA	SENT	-	-	-	-	-	-
\$026	T1M	R/W	-	-	-	T1M[4]	T1M[3]	T1M[2]	T1M[1]	T1M[0]	--0 0000
\$027	T1C	R/W	T1C[7]	T1C[6]	T1C[5]	T1C[4]	T1C[3]	T1C[2]	T1C[1]	T1C[0]	0000 0000
\$030	SYS	R/W	XSEL	OSTP	XSTP	TEST	WSKP	WAIT	-	-	0000 00--
\$03C	IREQ	R/W	-	-	IRBT	IRPT	IRT1	-	IRDAC	IRX	???? ????
\$03E	IENA	R/W	-	-	IEBT	IEPT	IET1	-	IEDAC	IEX	-- 00 0-00

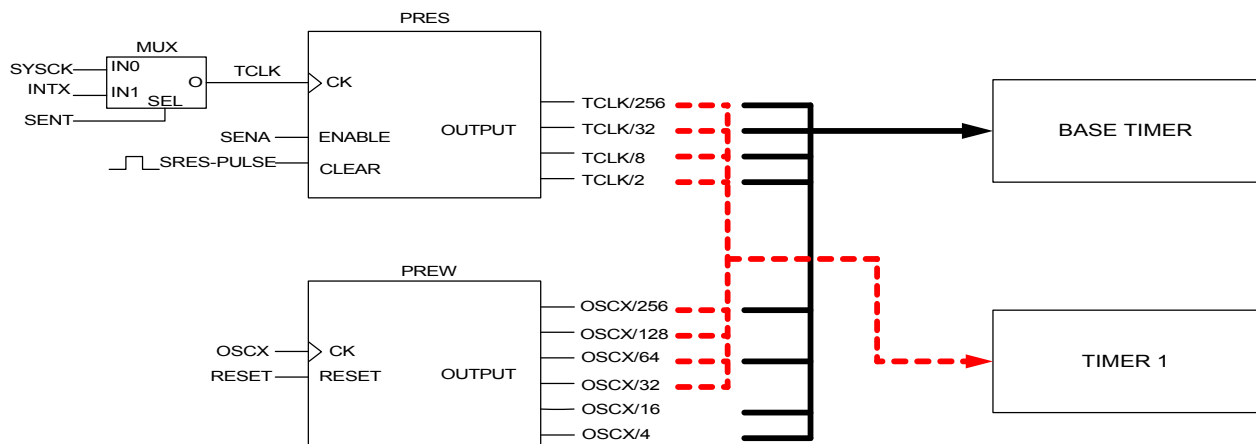

FIGURE 12-7: Prescaler for Timers

12.1 PRES

The prescaler PRES is an 8-bits counter as shown in Figure 12-7. Which provides four clock sources for base timer and timer1, and it is controlled by register PRS. The instruction read toward PRS will bring out the content of PRES and the

instruction write toward PRS will reset, enable or select clock sources for PRES.

When user set external interrupt as the input of PRES for event counter, combining PRES and Timer1 will get a 16bit-event counter.

TABLE 12-21: PRESCALER CONTROL REGISTER (PRS)

Address	Name	R/W	Bit 7	Bit 6	Bit 5	Bit 4	Bit 3	Bit 2	Bit 1	Bit 0	Default
\$023	PRS	R	PRS[7]	PRS[6]	PRS[5]	PRS[4]	PRS[3]	PRS[2]	PRS[1]	PRS[0]	1111 1111
		W	SRES	SENA	SENT	-	-	-	-	-	000 - - - - -

READ

Bit 7~0: **PRS[7~0]** : 1's complement of PRES counter

WRITE

Bit 7: **SRES** : Prescaler Reset bit
Write "1" to reset the prescaler (PRS[7~0])

Bit 6: **SENA** : Prescaler enable bit
0 = Disable prescaler counting
1 = Enable prescaler counting

Bit 5: **SENT** : Clock source(TCLK) selection for prescaller PRES
0 = Clock source from system clock "SYSCK"
1 = Clock source from external events "INTX"

12.2 PREW

The prescaler PREW is an 8-bits counter as shown in Figure 12-7. PREW provides four clock source for base timer and

timer1. It stops counting only if OSCX stops or hardware reset occurs.

12.3 Base timer

Base timer is an 8-bit up counting timer. When it overflows from \$FF to \$00, a timer interrupt request IRBT will be generated. Please refer to Figure 11-7. :

FIGURE 12-8: Structure of Base Timer

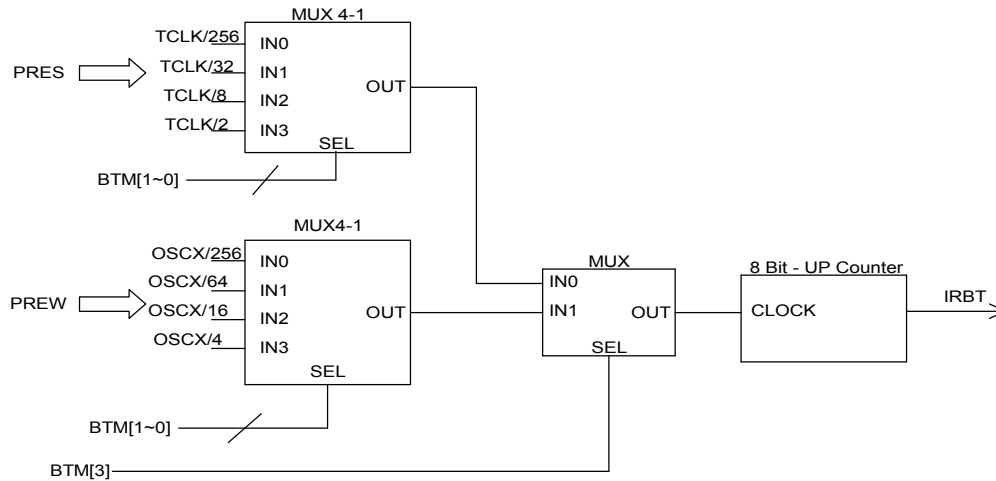

12.3.1 Clock source control for Base Timer

Several clock sources can be selected for Base Timer. Please refer to the following table:

TABLE 12-22: CLOCK SOURCE FOR BASE TIMER

* SENA	BTM[3]	BTM[2]	BTM[1]	BTM[0]	Base Timer source clock
0	0	X	X	X	STOP
1	0	X	0	0	TCLK / 256
1	0	X	0	1	TCLK / 32
1	0	X	1	0	TCLK / 8
1	0	X	1	1	TCLK / 2
X	1	X	0	0	OSCX / 256
X	1	X	0	1	OSCX / 64
X	1	X	1	0	OSCX / 16
X	1	X	1	1	OSCX / 4

* TCLK will stop when an '0' is written to SENA(PRS[6]).

12.4 Timer 1

The Timer1 is an 8-bit up counter. It can be used as a timer or an event counter. T1C(\$27) is a real time read/write counter. When an overflow from \$FF to \$00, a timer interrupt request IRT1 will be generated. Timer1 will stop counting when system clock stops. Please refer to Figure 11-8.

FIGURE 12-9: Timer1 Structure Diagram

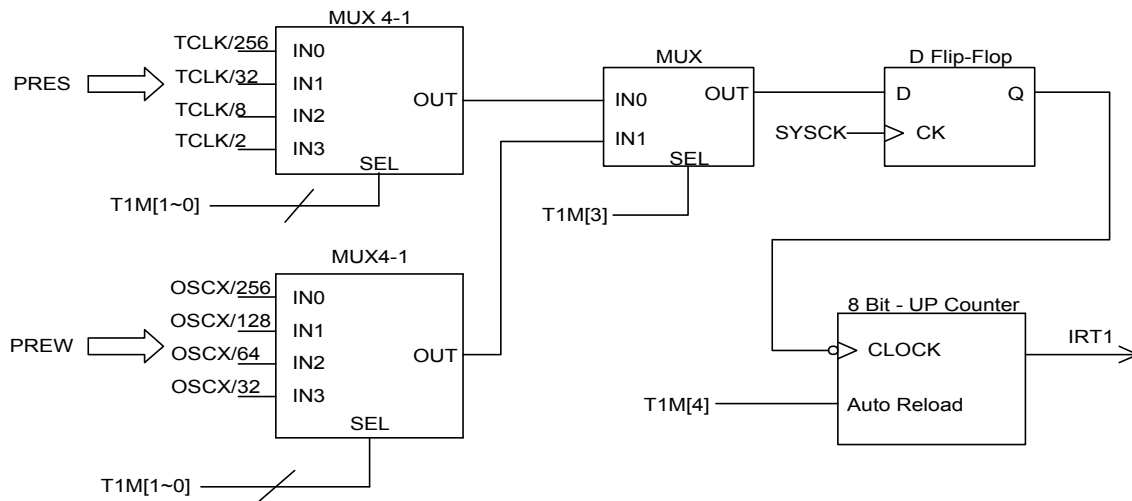

TABLE 12-23: TIMER1 COUNTING REGISTER (T1C)

Address	Name	R/W	Bit 7	Bit 6	Bit 5	Bit 4	Bit 3	Bit 2	Bit 1	Bit 0	Default
\$027	T1C	R/W	T1C[7]	T1C[6]	T1C[5]	T1C[4]	T1C[3]	T1C[2]	T1C[1]	T1C[0]	0000 0000

12.4.1.2

Bit 7-0: T1C[7-0] : Timer1 up counter register

12.4.1 Clock source control for Timer1

Several clock source can be chosen from for Timer1. It's very important that Timer1 can keep counting as long as SYSCK stays active. Refer to the following table:

TABLE 12-24: CLOCK SOURCE FOR TIMER1

* SENA	T1M[4]	T1M[3]	T1M[2]	T1M[1]	T1M[0]	Clock source	Auto-Reload
0	X	0	X	X	X	STOP	-
1	0	0	X	0	0	TCLK / 256	No
1	0	0	X	0	1	TCLK / 32	No
1	0	0	X	1	0	TCLK / 8	No
1	0	0	X	1	1	TCLK / 2	No
X	0	1	X	0	0	OSCX / 256	No
X	0	1	X	0	1	OSCX / 128	No
X	0	1	X	1	0	OSCX / 64	No
X	0	1	X	1	1	OSCX / 32	No
1	1	0	X	0	0	TCLK / 256	Yes
1	1	0	X	0	1	TCLK / 32	Yes
1	1	0	X	1	0	TCLK / 8	Yes
1	1	0	X	1	1	TCLK / 2	Yes
X	1	1	X	0	0	OSCX / 256	Yes
X	1	1	X	0	1	OSCX / 128	Yes
X	1	1	X	1	0	OSCX / 64	Yes
X	1	1	X	1	1	OSCX / 32	Yes

* TCLK would stop when SENA is set to 0.

13. PSG

13.1 Function description

The built-in dual channel Programmable Sound Generator (PSG) is controlled by registers. Its flexibility makes it useful in applications such as music synthesis, sound effects generation, audible alarms and tone signaling. In order to generate sound effects while allowing the processor to perform other tasks, the PSG can continue to produce sound after the initial commands have been given by the CPU. The structure of PSG was shown in FIGURE 13-11: and the

PSG clock source is shown in FIGURE 13-10: . ST2016A has three playing modes. First is that both channel0 (CH0) and channel1 (CH1) output square type tones. Second is CH0 outputs square tone, and CH1 outputs noise. Third mode is PWM DAC mode. Sounds of two channels are mixed into one signal and are outputted in the form of digital waveform from two pins, PSGOB/PSGO. Therefore one AC waveform can be performed.

FIGURE 13-10: Clock Source for PSG

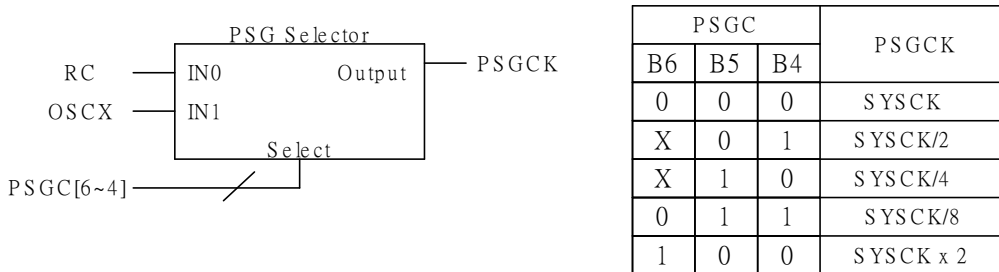
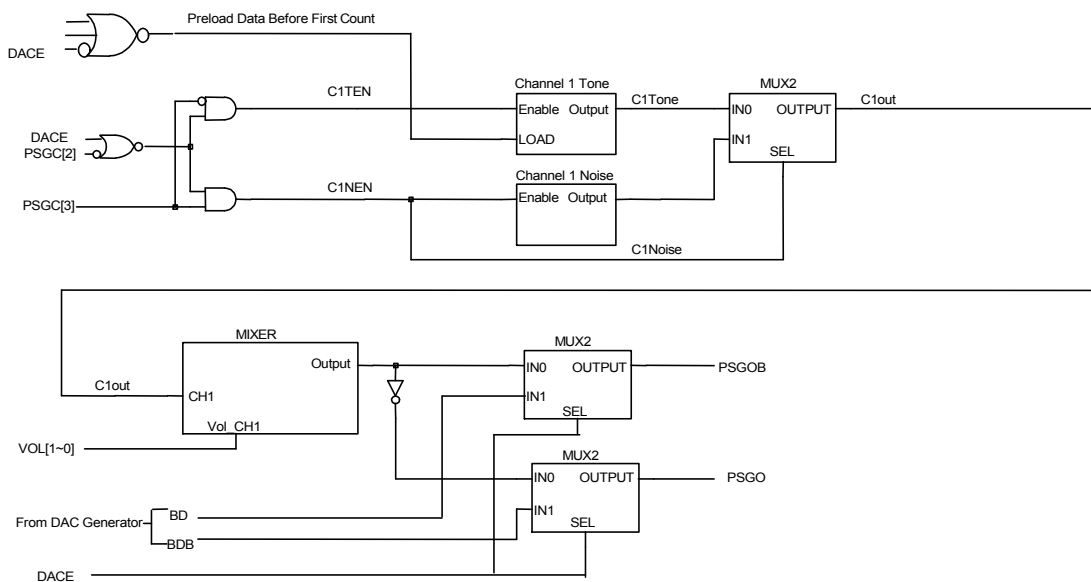

FIGURE 13-11: Program Sound Generator



CC

13.2 SUMMARY FOR PSG REGISTERS

Address	Name	R/W	Bit 7	Bit 6	Bit 5	Bit 4	Bit 3	Bit 2	Bit 1	Bit 0	Default
\$010	PSG0L	R/W	PSG0[7]	PSG0[6]	PSG0[5]	PSG0[4]	PSG0[3]	PSG0[2]	PSG0[1]	PSG0[0]	0000 0000
\$011	PSG0H	R/W	-	-	-	-	PSG0[11]	PSG0[10]	PSG0[9]	PSG0[8]	---- 0000
\$012	PSG1L	R/W	PSG1[7]	PSG1[6]	PSG1[5]	PSG1[4]	PSG1[3]	PSG1[2]	PSG1[1]	PSG1[0]	0000 0000
\$013	PSG1H	R/W	-	-	-	-	PSG1[11]	PSG1[10]	PSG1[9]	PSG1[8]	---- 0000
\$015	PSGC2	R/W	-	-	-	-	PSGOD	PSGOBD	PSGOE	PSGOBE	---- 1111
\$016	PSGC	R/W	-	PCK[2]	PCK[1]	PCK[0]	PRBS	C1EN	C0EN	DACE=0	- 000 0000
		R/W	-	PCK[2]	PCK[1]	PCK[0]	DMD[1]	DMD[0]	INH	DACE=1	- 000 0000
\$017	VOL	R/W	VOL1[3]	VOL1[2]	VOL1[1]	VOL1[0]	VOL0[3]	VOL0[2]	VOL0[1]	VOL0[0]	0000 0000

TABLE 13-25: CONTROL REGISTER FOR PSG OUTPUT (PSGC2)

Address	Name	R/W	Bit 7	Bit 6	Bit 5	Bit 4	Bit 3	Bit 2	Bit 1	Bit 0	Default
\$015	PSGC2	R/W	-	-	-	-	PSGOD	PSGOBD	PSGOE	PSGOBE	---- 1111

Bit 3: **PSGOD** : Data bit if PSGO is used as normal output pin.
 1 = PSGO is output High.
 0 = PSGO is output Low

Bit 2: **PSGOBD** : Data bit if PSGOB is used as normal output pin.
 1 = PSGOB is output High.
 0 = PSGOB is output Low

Bit 1: **PSGOE** : PSG output enable bit
 1 = PSGO is PSG data output pin.
 0 = PSGO is normal output pin

Bit 0: **PSGOBE** : PSG inverse signal output enable bit
 1 = PSGOB is PSG inverse data output pin.
 0 = PSGOB is normal output pin

TABLE 13-26: CONTROL REGISTER FOR PSG VOLUME (VOL)

Address	Name	R/W	Bit 7	Bit 6	Bit 5	Bit 4	Bit 3	Bit 2	Bit 1	Bit 0	Default
\$017	VOL	R/W	VOL1[3]	VOL1[2]	VOL1[1]	VOL1[0]	VOL0[3]	VOL0[2]	VOL0[1]	VOL0[0]	0000 0000

Bit 3~0: **VOL0[3~0]** : PSG volume control bit
 * 0000 = No sound output
 0001 = 1/16 volume (PSGCK must >= 320K Hz)
 0010 = 2/16 volume
 :
 1110 = 15/16 volume
 1111 = Maximum volume (PSGCK must >= 20K Hz)

Bit 7~4: **VOL1[3~0]** : PSG volume control bit
 * 0000 = No sound output
 0001 = 1/16 volume (PSGCK must >= 320K Hz)
 0010 = 2/16 volume
 :
 1110 = 15/16 volume
 1111 = Maximum volume (PSGCK must >= 20K Hz)

* Only use Channel-0 and VOL=0FFH , volume is maximum.

13.3 Tone Generator

The tone frequency is decided by PSGCK and 12-bit programmable divider (PSG0[11~0]) and (PSG1[11~0])
Please refer to Figure 12-11.

FIGURE 13-12: Channel0 PSG Tone Counter

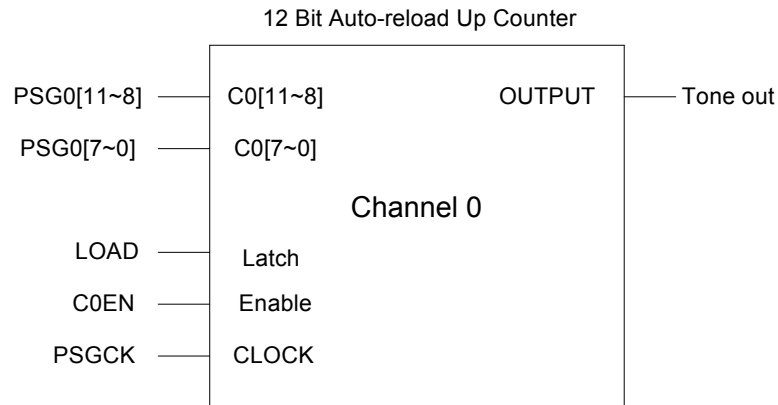

$$\text{Frequency of Channel 0 Tone} = \text{PSGCK} / (1000\text{H} - \text{PSG0}[11\sim0]) / 2$$

FIGURE 13-13: Channel1 PSG Tone Counter

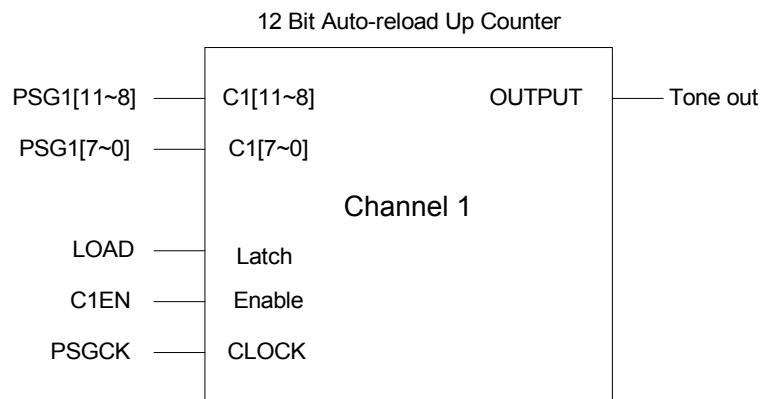

$$\text{Frequency of Channel 1 Tone} = \text{PSGCK} / (1000\text{H} - \text{PSG1}[11\sim0]) / 2$$

13.4 PSG Tone programming

To program tone generator, Tone or DAC function is defined by DACE, writing to C1EN will enable tone generator when

PSG is in tone function. Noise or tone function is selected by PRBS.

TABLE 13-27: PSG CONTROL REGISTER (PSGC)

Address	Name	R/W	Bit 7	Bit 6	Bit 5	Bit 4	Bit 3	Bit 2	Bit 1	Bit 0	Default
\$016	PSGC	R/W	-	PCK[2]	PCK[1]	PCK[0]	PRBS	C1EN	C0EN	DACE=0	- 000 0000
		R/W	-	PCK[2]	PCK[1]	PCK[0]	DMD[1]	DMD[0]	INH	DACE=1	- 000 0000

Bit 0: **DACE** : Tone(Noise) or DAC Generator selection bit
 1 = PSG is used as the DAC generator
 0 = PSG is used as the Tone(Noise) generator

Bit 1: **C0EN** : PSG Channel-0(Tone) enable bit
 1 = PSG0 enable
 0 = PSG0 disable

Bit 2: **C1EN** : PSG Channel-1(Tone or Noise) enable bit
 1 = PSG1 (Tone or Noise) enable
 0 = PSG 1(Tone or Noise) disable

Bit 3: **PRBS** : Tone or Noise generator selection bit
 1 = Noise generator
 0 = Tone generator

Bit 6~4: **PCK[2~0]** : clock source(PSGCK) selection for PSG and DAC
 000 = SYSCK
 X01 = SYSCK / 2
 X10 = SYSCK / 4
 011 = SYSCK / 8
 100 = SYSCK * 2

13.5 Noise Generator Control

Noise generator is shown in Figure 12-12., which base frequency is controlled by PSG1L[5~0].

FIGURE 13-14: Noise Generator Diagram

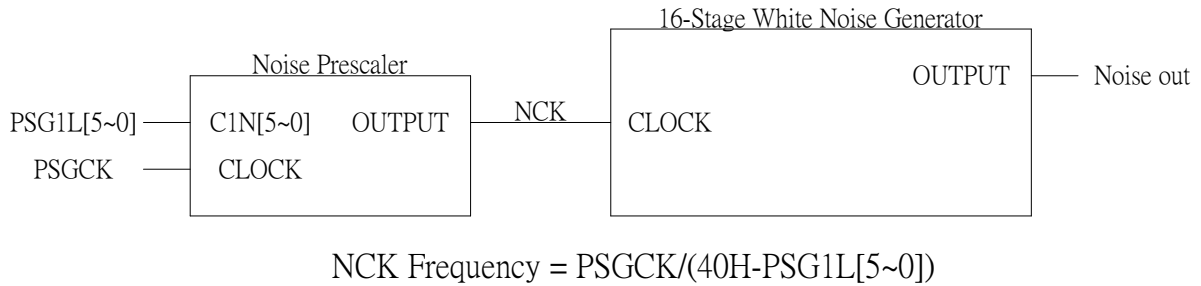

13.6 PSG Noise programming

To program noise generator, Noise or DAC function is defined by DACE. Writing a “1” to C1EN will enable noise generator when PSG is in noise mode.

13.7 PSG Application Circuit

Sounds of two channels are modulated by PSGCK and combine together into one AC signal. Then it outputs on

PSGOB and PSGO. Positive part of the AC signal is output from PSGO while the negative part is from PSGOB.

FIGURE 13-15: PSG application circuit

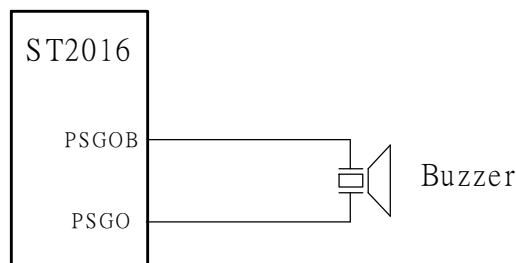

14. Digital DAC

A built-in digital DAC is for analog sampling data or voice signals. The structure of DAC is shown in Figure 13-13. There is an interrupt signal from DAC to CPU whenever DAC

data update is needed and the same signal will decide the sampling rate of voice. In DAC mode, the OSC can't less 4 M Hz.

TABLE 14-28: SUMMARY FOR DAC REGISTERS

Address	Name	R/W	Bit 7	Bit 6	Bit 5	Bit 4	Bit 3	Bit 2	Bit 1	Bit 0	Default
\$012	PSG1L	R/W	PSG1[7]	PSG1[6]	PSG1[5]	PSG1[4]	PSG1[3]	PSG1[2]	PSG1[1]	PSG1[0]	0000 0000
\$013	PSG1H	R/W	-	-	-	-	PSG1[11]	PSG1[10]	PSG1[9]	PSG1[8]	---- 0000
\$014	DAC	R/W	DAC[7]	DAC[6]	DAC[5]	DAC[4]	DAC[3]	DAC[2]	DAC[1]	DAC[0]	0000 0000
\$015	PSGC2	R/W	-	-	-	-	PSGOD	PSGOBD	PSGOE	PSGOBE	---- 1111
\$016	PSGC	R/W	-	PCK[2]	PCK[1]	PCK[0]	PRBS	C1EN	C0EN	DACE=0	- 000 0000
		R/W	-	PCK[2]	PCK[1]	PCK[0]	DMD[1]	DMD[0]	INH	DACE=1	- 000 0000

TABLE 14-29: DAC DATA REGISTER (DAC)

Address	Name	R/W	Bit 7	Bit 6	Bit 5	Bit 4	Bit 3	Bit 2	Bit 1	Bit 0	Default
\$014	DAC	R/W	DAC[7]	DAC[6]	DAC[5]	DAC[4]	DAC[3]	DAC[2]	DAC[1]	DAC[0]	0000 0000

Bit 7~0: **DAC[7~0]** : DAC output data

Note: For Single-Pin Single Ended mode, the effective output resolution is 7 bit.

TABLE 14-30: DAC CONTROL REGISTER (PSGC)

Address	Name	R/W	Bit 7	Bit 6	Bit 5	Bit 4	Bit 3	Bit 2	Bit 1	Bit 0	Default
\$016	PSGC	R/W	-	PCK[2]	PCK[1]	PCK[0]	PRBS	C1EN	-	DACE=0	- 000 00-0
		R/W	-	PCK[2]	PCK[1]	PCK[0]	DMD[1]	DMD[0]	INH	DACE=1	- 000 0000

Bit 0: **DACE** : PSG play as Tone(Noise) or DAC Generator selection bit
 1 = PSG is used as DAC Generator
 0 = PSG is used as Tone(Noise) Generator

Bit 1: **INH** : DAC output inhibit control bit
 1 = DAC output inhibit
 0 = DAC output enable

Bit 3~2: **DMD[1~0]** : DAC output mode selection
 00 = Single-Pin mode : 7 bit resolution
 01 = Two-Pin Two Ended mode : 8 bit resolution
 10 = Reserved
 11 = Two-Pin Push Pull mode : 8 bit resolution

Bit 6~4: **PCK[2~0]** : PSGCK selection for PSG and DAC
 000 = SYSCK
 X01 = SYSCK / 2
 X10 = SYSCK / 4
 011 = SYSCK / 8
 100 = SYSCK *2

* **In DAC mode, PSGCK must select SYSCK.**

14.2 Sampling Rate Control

The sample rate is controlled by PSG1L and PSG1H. PSG1[11~7] controls sample rate/post scaling and PSG1[6] must set '0' and PSG1[5~0] must set '1'. The input clock

source is controlled by PCK[2~0]. The block diagram is shown as the following:

FIGURE 14-16: DAC Generator Diagram

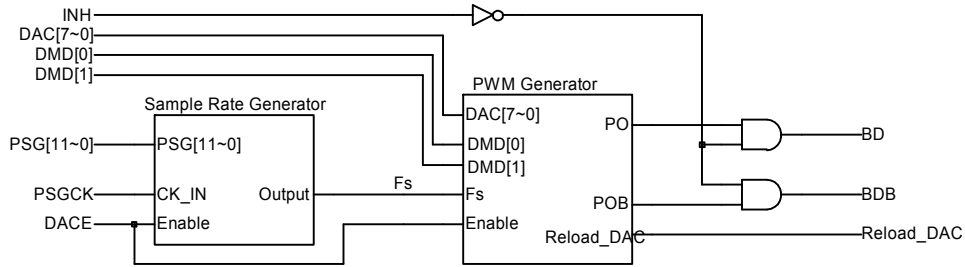
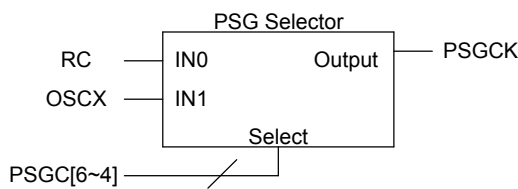

FIGURE 14-17: Clock Source for DAC



PSGC			PSGCK
B6	B5	B4	
0	0	0	YSCK
X	0	1	YSCK/2
X	1	0	YSCK/4
0	1	1	YSCK/8
1	0	0	YSCK x 2

TABLE 14-31: DAC Sample Rate Description (RC_{osc} = 2MHz)

DAC interrupt frequency	PSGC b6, b5, b4	PSG1H, PSG1L
8K	100	00001111, 00111111
16K	100	00001111, 10111111

14.3 PWM DAC Mode Select

The PWM DAC generator has three modes, Single-pin mode, Two-pin two ended mode and Two-pin push pull

mode. They are depended on the application used. The DAC mode is controlled by DMD[1~0]. (TABLE 13-31)

14.3.1 Single-Pin Mode (Accurate to 7 bits)

Single-pin mode is designed for use with a single-transistor amplifier. It has 7 bits of resolution. The duty cycle of the **PSGO** is proportional to the output value. If the output value is 0, the duty cycle is 50%. As the output value increases from 0 to 63, the duty cycle goes from being high 50% of the

time up to 100% high. As the value goes from 0 to -64, the duty cycle decreases from 50% high to 0%. **PSGOB** is inverse of **PSGO**'s waveform. Figure 13-15 shows the **PSGO** wave-forms.

FIGURE 14-18: Single-Pin PWM DAC Wave-form

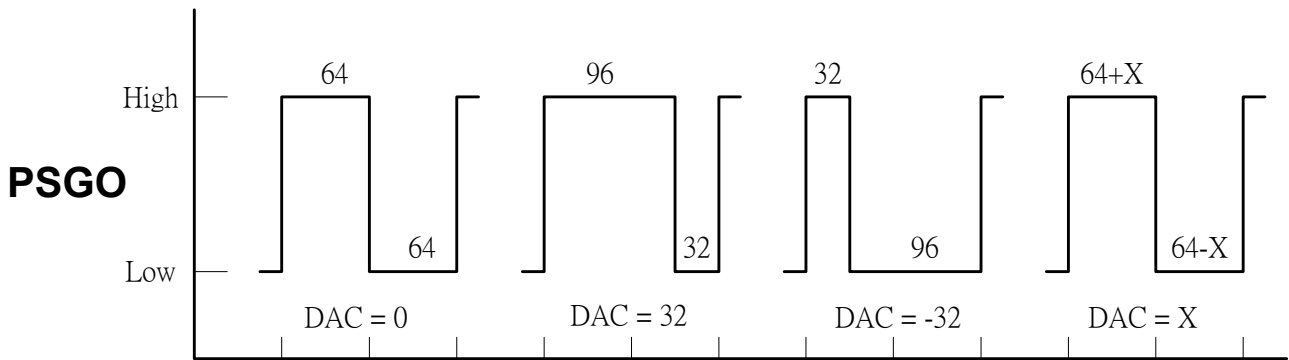
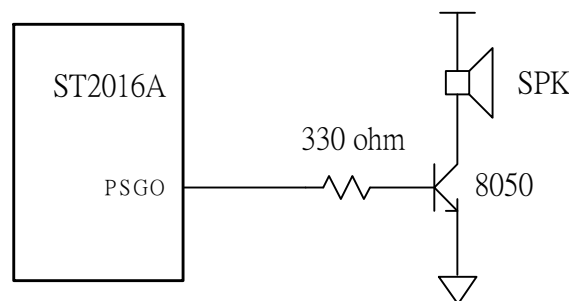

FIGURE 14-19: Single-Pin Application Circuit



14.3.2 Two-Pin Two Ended mode (Accurate to 8 bits)

Two-Pin Two Ended mode is designed for use with a single transistor amplifier. It requires two pins that **PSGOB** and **PSGO**. When the DAC value is positive, **PSGO** goes high with a duty cycle proportional to the output value, while **PSGOB** stays high. When the DAC value is negative, **PSGOB** goes low with a duty cycle proportional to the output value, while **PSGO** stays low. This mode offers a resolution of 8 bits.

Figure 13-17 shows examples of DAC output waveforms with different output values. Each pulse of the DAC is divided into 128 segments per sample period. For a positive output value $x=0$ to 127, **PSGO** goes high for X segments while **PSGOB** stays high. For a negative output value $x=0$ to -127, **PSGOB** goes low for $|X|$ segments while **PSGO** stays low.

FIGURE 14-20: Two-Pin Two Ended PWM DAC Wave-form

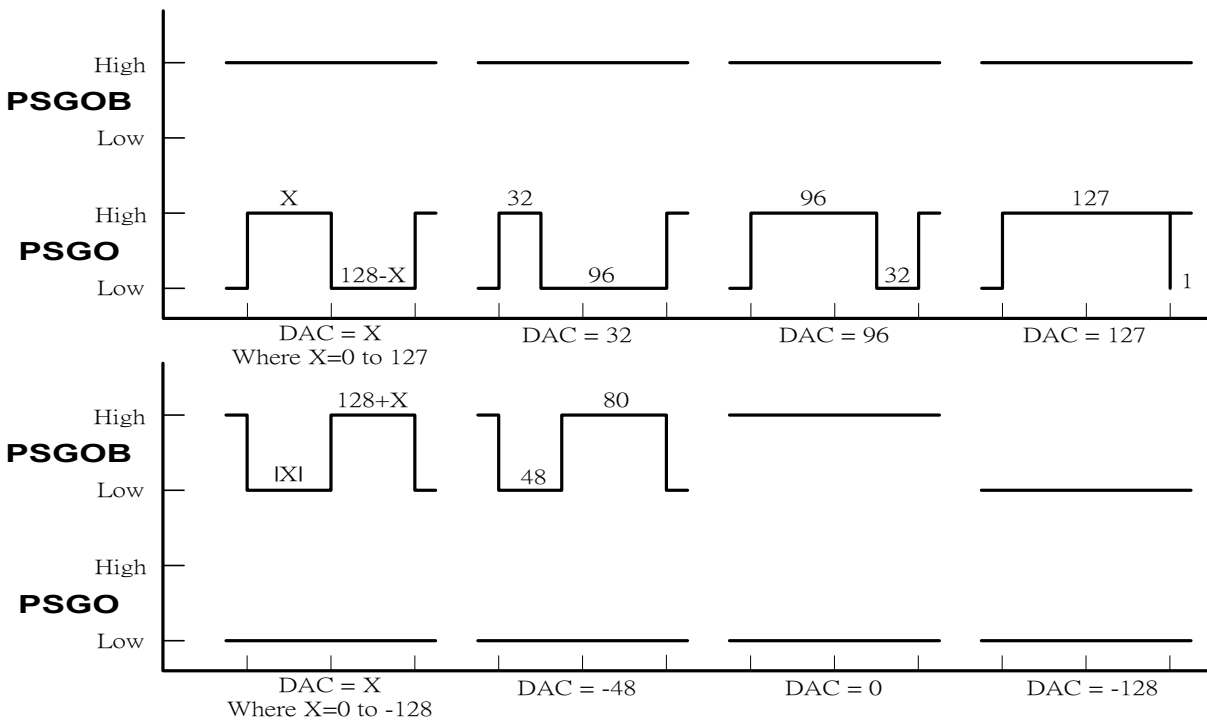
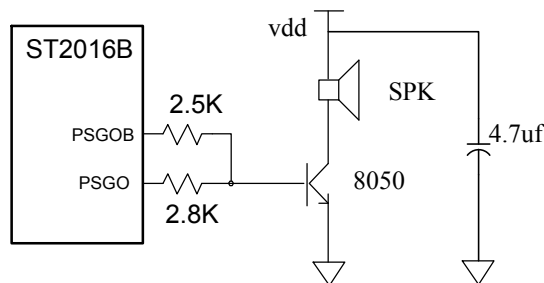

FIGURE 14-21: Two-Pin Two Ended mode Application Circuit



14.3.3 Two-Pin Push Pull mode (Accurate to 8 bits)

Two-Pin Push Pull mode is designed for buzzer. It requires two pins that **PSGOB** and **PSGO**. When the DAC value is 0, both pins are low. When the DAC value is positive, **PSGO** goes high with a duty cycle proportional to the output value, while **PSGOB** stays low. When the DAC value is negative, **PSGOB** goes high with a duty cycle proportional to the output value, while **PSGO** stays low. This mode offers a resolution of 8 bits.

Figure 13-19 shows examples of DAC output waveforms with different output values. Each pulse of the DAC is divided into 128 segments per sample period. For a positive output value $x=0$ to 127, **PSGO** goes high for X segments while **PSGOB** stays low. For a negative output value $x=0$ to -127, **PSGOB** goes high for $|X|$ segments while **PSGO** stays low.

FIGURE 14-22: Two-Pin Push Pull Mode Waveform

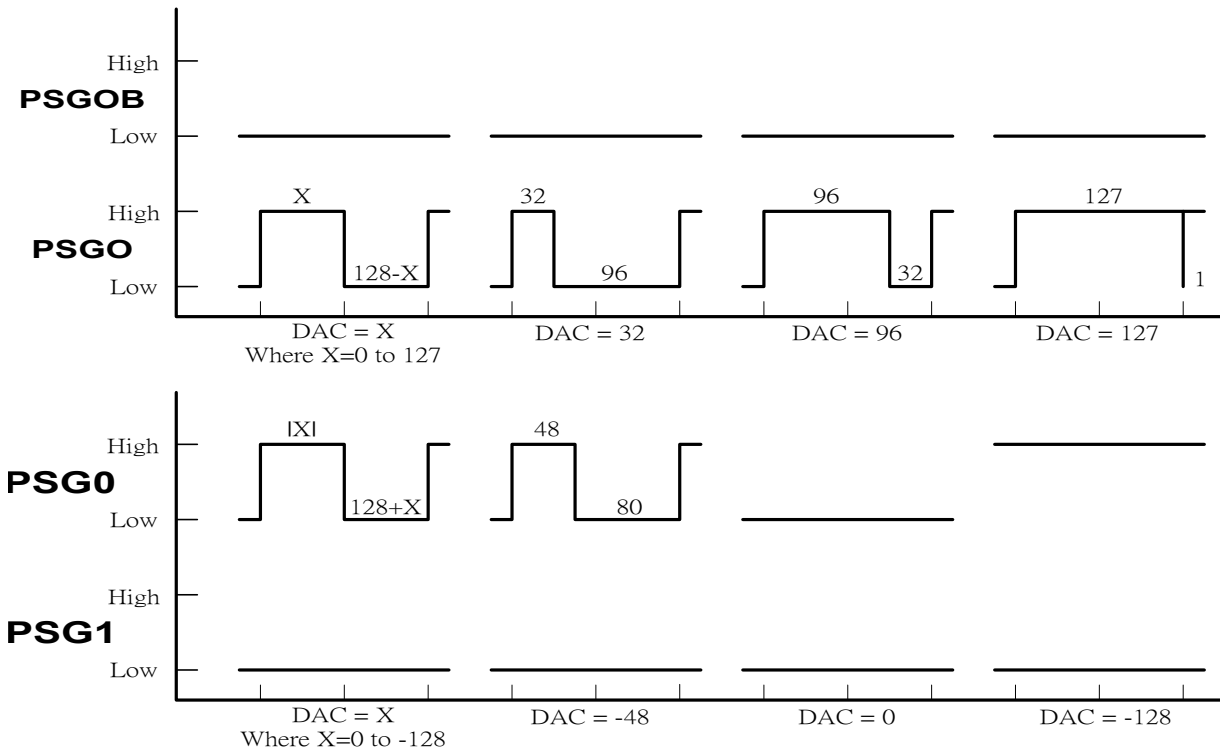
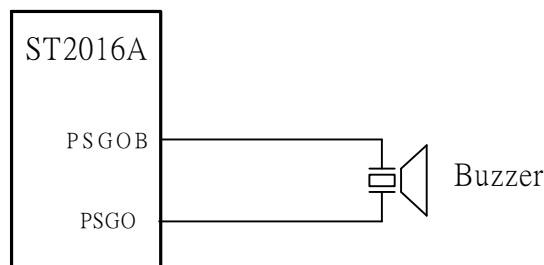

FIGURE 14-23: Two-Pin Push Pull Application Circuit



15. LCD

The ST2016A can drive up to 320 dots of LCD panel directly. The LCD driver can control by 1/4 duty(160 dots) and 1/8 duty (320 dots). LCD block include display RAM (\$200~\$227) for storing the display data, 40-segment output pins (SEG0~SEG39), 8-common output pins (COM0~COM7).

All LCD RAM are random after power on reset. The bias voltage circuits of the LCD display is built-in and no external resistor is needs.

FIGURE 15-24: Clock source of LCD

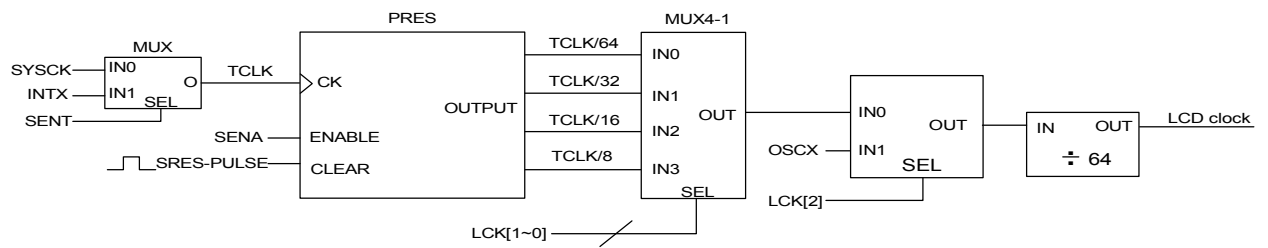

15.1 LCD driver 1/4 duty output

1/4 duty , 1/3 bias LCD signal

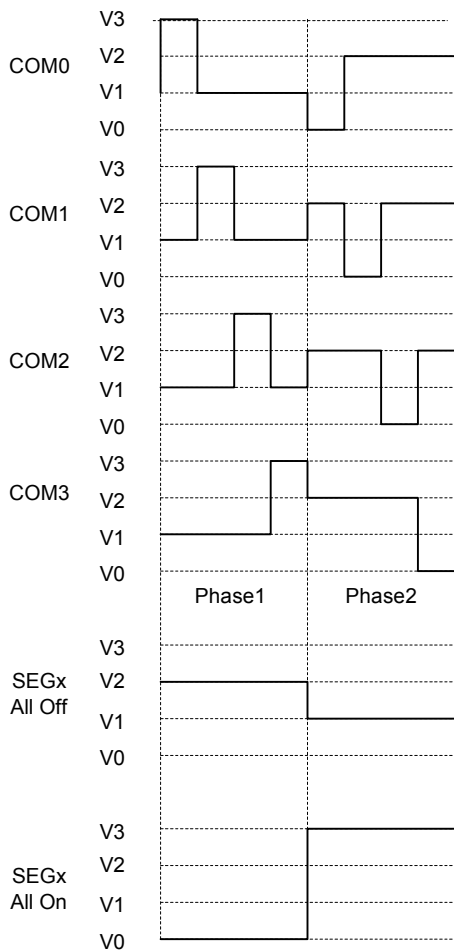

Example

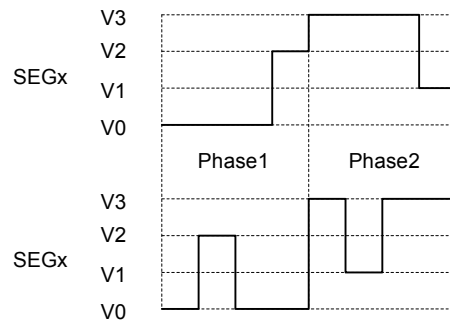
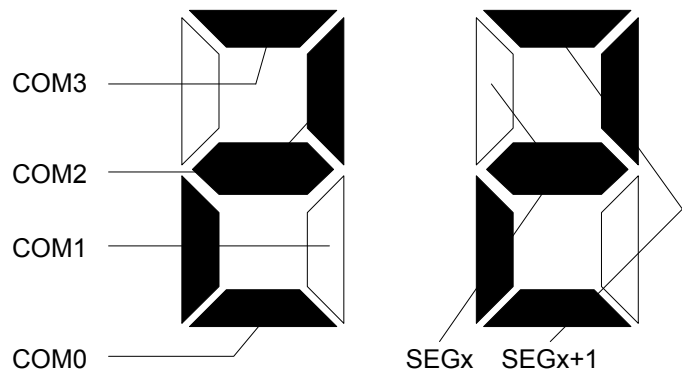

15.2 LCD driver 1/8 duty output

1/8 duty , 1/4 bias LCD signal

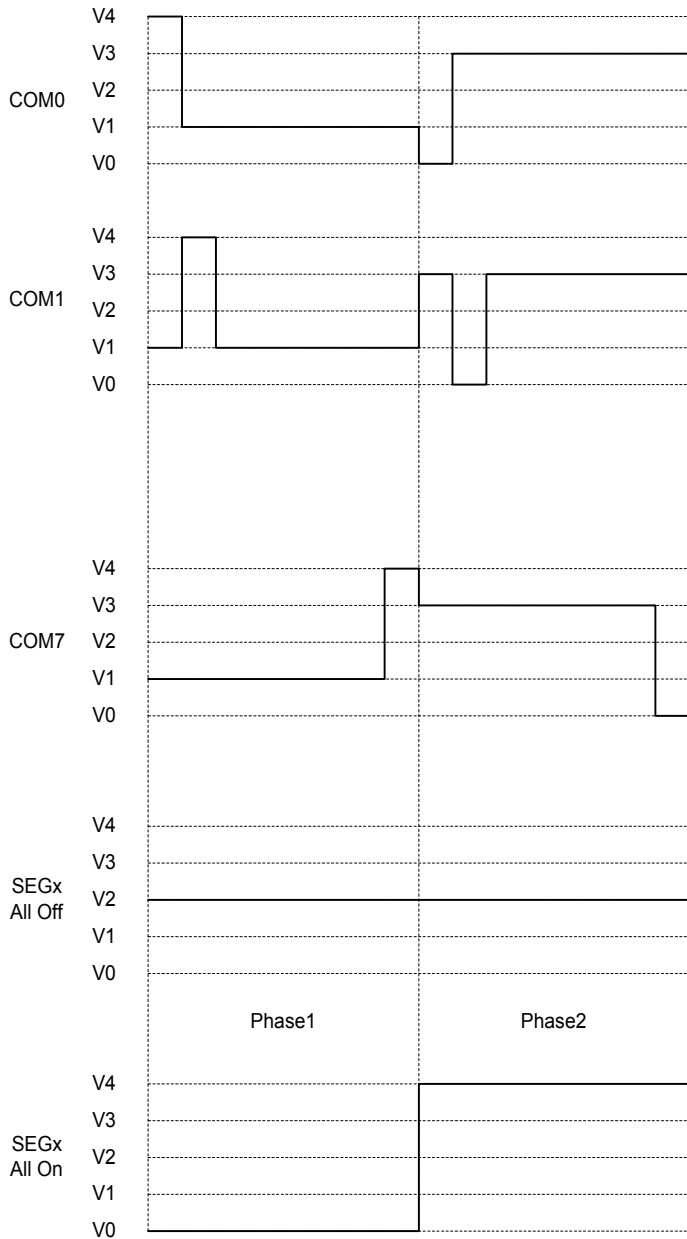

Example

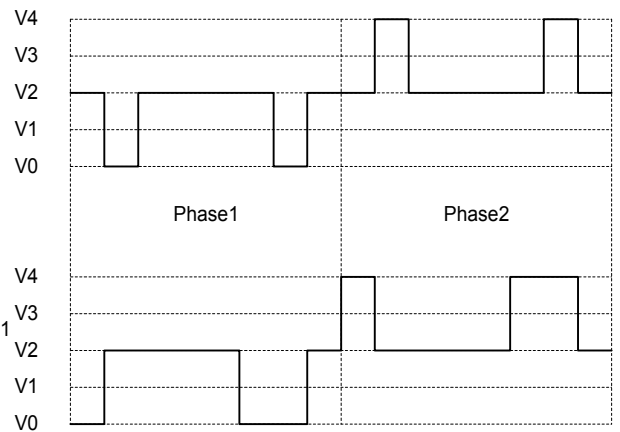
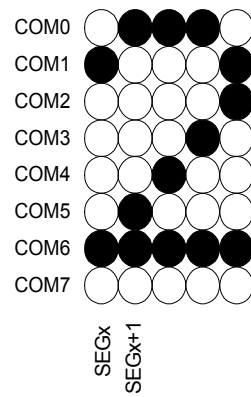

15.3 LCD Control Register

15.3.1.1 LCD Segment Number Selection Register (LSEL)

Address	Name	R/W	Bit 7	Bit 6	Bit 5	Bit 4	Bit 3	Bit 2	Bit 1	Bit 0	Default
\$039	LSEL	R/W	LSEL[7]	-	-	LSEL[4]	LSEL[3]	LSEL[2]	LSEL[1]	LSEL[0]	1 - - 1 1111

Bit 7 **LSEL[7]** :
 1 = PA[7~4] will use as LCD segment driver SEG[3~0]
 0 = PA[7~4] will be general purpose I/O

Bit 4~0: **LSEL[4~0]** : LCD segment number selection

LSEL[4:0]	Pad Definition															
	PAD 48	PAD 47	PAD 46	PAD 45	PAD 44	PAD 43	PAD 42	PAD 41	PAD 40	PAD 39	PAD 38	PAD 37	PAD 36	PAD 35	PAD 34	PAD 33
0 xxxx	PC0	PC1	PC2	PC3	PC4	PC5	PC6	PC7	PB0	PB1	PB2	PB3	PB4	PB5	PB6	PB7
1 0000	SEG24	PC1	PC2	PC3	PC4	PC5	PC6	PC7	PB0	PB1	PB2	PB3	PB4	PB5	PB6	PB7
1 0001	SEG24	SEG25	PC2	PC3	PC4	PC5	PC6	PC7	PB0	PB1	PB2	PB3	PB4	PB5	PB6	PB7
1 0010	SEG24	SEG25	SEG26	PC3	PC4	PC5	PC6	PC7	PB0	PB1	PB2	PB3	PB4	PB5	PB6	PB7
1 0011	SEG24	SEG25	SEG26	SEG27	PC4	PC5	PC6	PC7	PB0	PB1	PB2	PB3	PB4	PB5	PB6	PB7
1 0100	SEG24	SEG25	SEG26	SEG27	SEG28	PC5	PC6	PC7	PB0	PB1	PB2	PB3	PB4	PB5	PB6	PB7
1 0101	SEG24	SEG25	SEG26	SEG27	SEG28	SEG29	PC6	PC7	PB0	PB1	PB2	PB3	PB4	PB5	PB6	PB7
1 0110	SEG24	SEG25	SEG26	SEG27	SEG28	SEG29	SEG30	PC7	PB0	PB1	PB2	PB3	PB4	PB5	PB6	PB7
1 0111	SEG24	SEG25	SEG26	SEG27	SEG28	SEG29	SEG30	SEG31	PB0	PB1	PB2	PB3	PB4	PB5	PB6	PB7
1 1000	SEG24	SEG25	SEG26	SEG27	SEG28	SEG29	SEG30	SEG31	SEG32	PB1	PB2	PB3	PB4	PB5	PB6	PB7
1 1001	SEG24	SEG25	SEG26	SEG27	SEG28	SEG29	SEG30	SEG31	SEG32	SEG33	PB2	PB3	PB4	PB5	PB6	PB7
1 1010	SEG24	SEG25	SEG26	SEG27	SEG28	SEG29	SEG30	SEG31	SEG32	SEG33	SEG34	PB3	PB4	PB5	PB6	PB7
1 1011	SEG24	SEG25	SEG26	SEG27	SEG28	SEG29	SEG30	SEG31	SEG32	SEG33	SEG34	SEG35	PB4	PB5	PB6	PB7
1 1100	SEG24	SEG25	SEG26	SEG27	SEG28	SEG29	SEG30	SEG31	SEG32	SEG33	SEG34	SEG35	SEG36	PB5	PB6	PB7
1 1101	SEG24	SEG25	SEG26	SEG27	SEG28	SEG29	SEG30	SEG31	SEG32	SEG33	SEG34	SEG35	SEG36	SEG37	PB6	PB7
1 1110	SEG24	SEG25	SEG26	SEG27	SEG28	SEG29	SEG30	SEG31	SEG32	SEG33	SEG34	SEG35	SEG36	SEG37	SEG38	PB7
1 1111	SEG24	SEG25	SEG26	SEG27	SEG28	SEG29	SEG30	SEG31	SEG32	SEG33	SEG34	SEG35	SEG36	SEG37	SEG38	SEG39

15.4 LCD control register

TABLE 15-32: LCD CONTROL REGISTERS

Address	Name	R/W	Bit 7	Bit 6	Bit 5	Bit 4	Bit 3	Bit 2	Bit 1	Bit 0	Default
\$020	LCK	R/W	DRV[4]	DRV[3]	DRV[2]	DRV[1]	DRV[0]	LCK[2]	LCK[1]	LCK[0]	0000 0000
\$023	PRS	R/W	SRES	SENA	SENT	-	-	-	-	-	000 - - - - -
\$03A	LCTL	R/W	LPWR	BLANK	DUTY	SCAN	CTR[3]	CTR[2]	CTR[1]	CTR[0]	1000 0000

TABLE 15-33: LCD FREQUENCY REGISTER (LCK)

Address	Name	R/W	Bit 7	Bit 6	Bit 5	Bit 4	Bit 3	Bit 2	Bit 1	Bit 0	Default
\$020	LCK	R/W	DRV[4]	DRV[3]	DRV[2]	DRV[1]	DRV[0]	LCK[2]	LCK[1]	LCK[0]	0000 0000

Bit 7~3: DRV[4~0] : LCD driving strength control.

LCK[7:3]	Driving strength	1/4 Duty consumption (uA)	1/8 Duty consumption (uA)	LCK[7:3]	Driving strength	1/4 Duty consumption (uA)	1/8 Duty consumption (uA)
00000	Level 32(max.)	66.54	50.38	10000	Level 16	38.15	28.97
00001	Level 31	64.79	49.04	10001	Level 15	36.36	27.61
00010	Level 30	62.97	47.7	10010	Level 14	34.58	26.29
00011	Level 29	61.21	46.36	10011	Level 13	32.81	24.96
00100	Level 28	59.09	45.04	10100	Level 12	31.04	23.62
00101	Level 27	59.42	43.69	10101	Level 11	29.28	22.29
00110	Level 26	55.89	42.36	10110	Level 10	27.47	20.94
00111	Level 25	54.1	41.01	10111	Level 9	25.7	19.6
01000	Level 24	52.32	39.66	11000	Level 8	23.91	18.26
01001	Level 23	50.55	38.34	11001	Level 7	22.14	16.95
01010	Level 22	48.79	36.98	11010	Level 6	20.36	15.58
01011	Level 21	47.01	35.66	11011	Level 5	18.59	14.27
01100	Level 20	45.23	34.32	11100	Level 4	16.79	12.91
01101	Level 19	43.44	32.97	11101	Level 3	15	11.56
01110	Level 18	41.69	31.66	11110	Level 2	13.18	10.23
01111	Level 17	39.91	30.31	11111	Level 1(mini.)	11.39	8.87

*** Measure Condition: Vdd=3V, LCD frame rate=64Hz, OSCX on, in WAI1.

Bit 2~0: LCK[2~0] : LCD clock source

LCK[2:0]	Frame Rate
000	OSC / 131072 (4MHz / 131072 = 30.5Hz)
001	OSC / 65536 (4MHz / 65536 = 61.0Hz)
010	OSC / 32768 (4MHz / 32768 = 122.1Hz)
011	OSC / 16384 (4MHz / 16384 = 244.1Hz)
1XX	OSCX / 512 (32768 / 512 = 64Hz)

Note: If LCD clock source is from OSCX, after power on, wait one second for OSCX to be stable and then turn on LCD.

* SENA must switch "1". (refer to FIGURE 14-21)

TABLE 15-34: LCD CONTROL REGISTER (LCTL)

Address	Name	R/W	Bit 7	Bit 6	Bit 5	Bit 4	Bit 3	Bit 2	Bit 1	Bit 0	Default																																				
\$03A	LCTL	R/W	LPWR	BLANK	DUTY	SCAN	CTR[3]	CTR[2]	CTR[1]	CTR[0]	1000 0000																																				
<p>Bit 7: LPWR : LCD power ON/OFF bit 1 = LCD power OFF 0 = LCD power ON</p> <p>Bit 6: BLANK : LCD display ON/OFF bit 1 = Disable LCD display (Common line is still scanning) 0 = Enable LCD display</p> <p>Bit 5: DUTY : LCD duty control bit 1 = 1/8 duty (1/4 bias) 0 = 1/4 duty (1/3 bias)</p> <p>Bit 4: SCAN : LCD segment keyboard scan function 1 = Enable LCD keyboard awaking pulse in LCD waveforms 0 = Disable LCD keyboard awaking pulse</p> <p>Bit 2~1: CTR[3-0] : LCD Contrast Control</p> <table border="1" style="width: 100%; border-collapse: collapse;"> <thead> <tr> <th colspan="4" style="text-align: center;">Frame Rate = 64Hz (DUTY=1/8 , DUTY=1/4)</th> </tr> </thead> <tbody> <tr> <td>0000</td> <td>= contrast level</td> <td>16 (maximum)</td> <td>1000 = contrast level 8</td> </tr> <tr> <td>0001</td> <td>= contrast level</td> <td>15</td> <td>1001 = contrast level 7</td> </tr> <tr> <td>0010</td> <td>= contrast level</td> <td>14</td> <td>1010 = contrast level 6</td> </tr> <tr> <td>0011</td> <td>= contrast level</td> <td>13</td> <td>1011 = contrast level 5</td> </tr> <tr> <td>0100</td> <td>= contrast level</td> <td>12</td> <td>1100 = contrast level 4</td> </tr> <tr> <td>0101</td> <td>= contrast level</td> <td>11</td> <td>1101 = contrast level 3</td> </tr> <tr> <td>0110</td> <td>= contrast level</td> <td>10</td> <td>1110 = contrast level 2</td> </tr> <tr> <td>0111</td> <td>= contrast level</td> <td>9</td> <td>1111 = contrast level 1 (minimum)</td> </tr> </tbody> </table>												Frame Rate = 64Hz (DUTY=1/8 , DUTY=1/4)				0000	= contrast level	16 (maximum)	1000 = contrast level 8	0001	= contrast level	15	1001 = contrast level 7	0010	= contrast level	14	1010 = contrast level 6	0011	= contrast level	13	1011 = contrast level 5	0100	= contrast level	12	1100 = contrast level 4	0101	= contrast level	11	1101 = contrast level 3	0110	= contrast level	10	1110 = contrast level 2	0111	= contrast level	9	1111 = contrast level 1 (minimum)
Frame Rate = 64Hz (DUTY=1/8 , DUTY=1/4)																																															
0000	= contrast level	16 (maximum)	1000 = contrast level 8																																												
0001	= contrast level	15	1001 = contrast level 7																																												
0010	= contrast level	14	1010 = contrast level 6																																												
0011	= contrast level	13	1011 = contrast level 5																																												
0100	= contrast level	12	1100 = contrast level 4																																												
0101	= contrast level	11	1101 = contrast level 3																																												
0110	= contrast level	10	1110 = contrast level 2																																												
0111	= contrast level	9	1111 = contrast level 1 (minimum)																																												

15.5 Keyboard-scan Function on LCD drives

When the LCTL[4] is set to "1", the SCAN function will be enabled. The LCD waveform will appear Keyboard Awakening

Pulses. These pulses are used as keyboard scan line to trigger Port-A interrupt if the keys have being pressed.

FIGURE 15-25: LCD Segment Waveform (Without Keyboard Awakening Pulses)

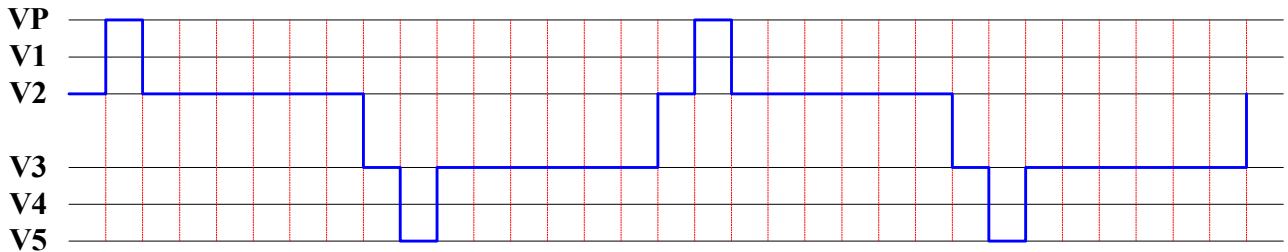

FIGURE 15-26: LCD Common Waveform (Without Keyboard Awakening Pulses)

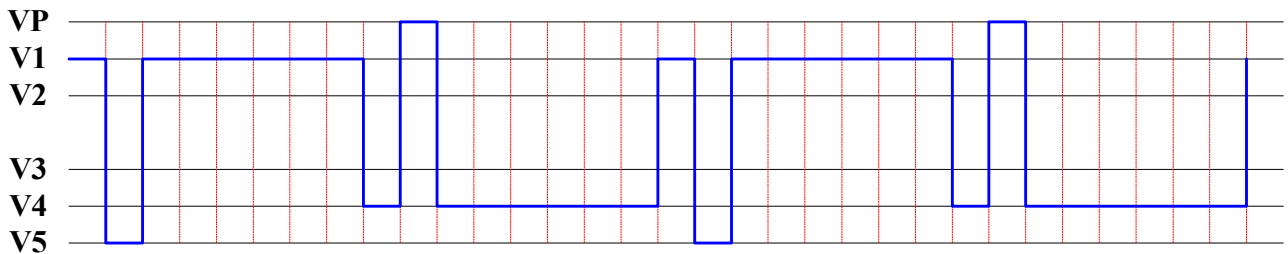

FIGURE 15-27: LCD Segment Waveform (With Keyboard Awakening Pulses)

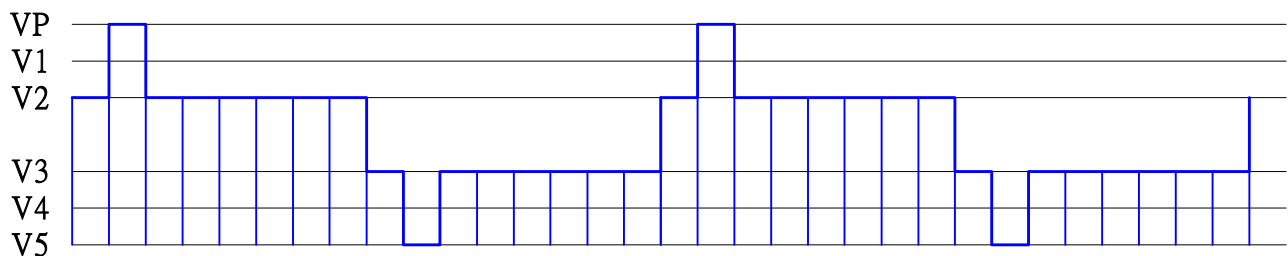
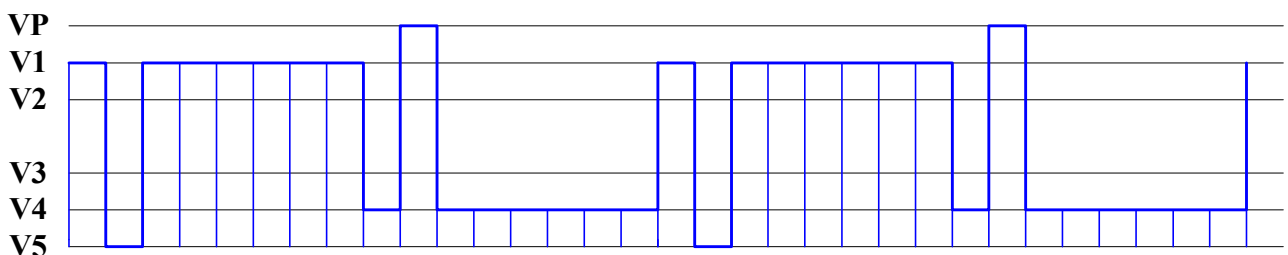

FIGURE 15-28: LCD Common Waveform (With Keyboard Awakening Pulses)



15.5.1 Keyboard-scan Function Example:

- a. Keyboard : 64Keys (8x8)
- b. Return Lines : Port-A
- c. Scan Lines : Port-B

INITIAL_Port_And_LCD

```

SMB4 <LCTL           ;;Enable Keyboard Awaking Pulses Waveform
LDA  #00011111B      ;;Set all shared pins to be segments
STA  <LSEL

STZ  <PCA            ;;Set Port-A as Inputs for Return Line
LDA  #FFH
STA  <PA             ;;Port-A Pull-High
STA  <PCB            ;;Set Port-B as Outputs for Scan Line
LDA  #11000000B
STA  <PMCR           ;;Enable Pull up & Debounce
LDA  #00010000B
STA  <IENA           ;;Enable Port-A Interrupt
LDA  <PA             ;;Keep Port-A last state
LDA  #$FF
STA  <PAK            ;;Port-A used as keyboard return line
STZ  <IREQ           ;;Reset Interrupt Request Register

CLI
    
```

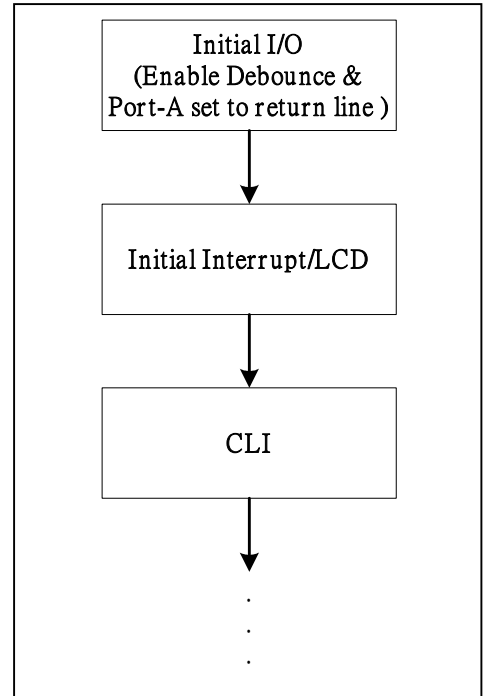

Interrupt-Subroutine

```

Port_ISR
  PHA
  PHX

  LDA #11111110B      ;;Initial scanning value for Port-B
  STA <ScanValue

?Scan_PB
  STA <PB
  STZ <PAK           ;; Port-A used as normal I/O
  RMB3 <LSEL        ;;Change segments to be Port-B
  LDX #$FF
  :
  :
  wait 12us ;       ;Wait for return line to be stable
  :
  RMB4 <LCTL        ;If keyboard awaking pulses and hardware
  LDA <PA           ;debounce are enabled together, keyboard awaking
  SMB4 <LCTL        ;pulses must be disabled before latch Port-A.

  SMB3 <LSEL        ;;Change Port-B to be segments
  STX <PAK         ;;Port-A used as keyboard return line
  JSR Store-Key-Data ;;This subroutine should be defined by user
  ROL <Scanvalue   ;;Shift scanning value left
  LDA <Scanvalue
  BCS ?Scan_PB
  :
  :
  PLX
  PLA
  RTI
  
```

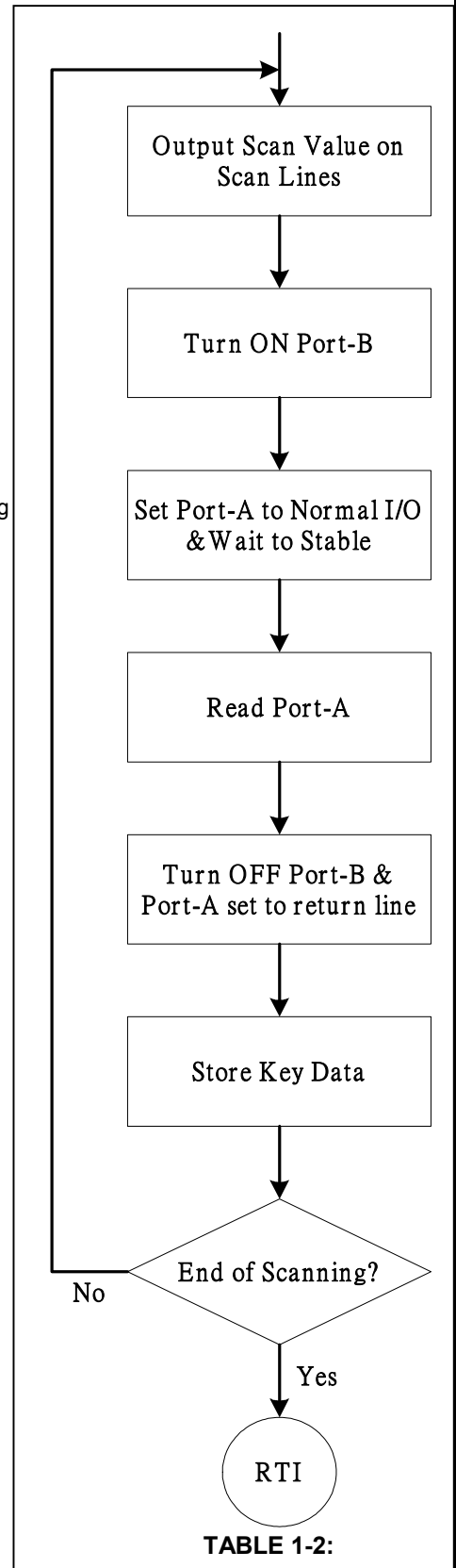

15.6 LCD RAM map

The LCD RAM map is shown as following:

TABLE 15-35: LCD RAM MAPPING

SEG	ADDRESS	COM0	COM1	COM2	COM3	COM4	COM5	COM6	COM7
0	200H	Bit 0	Bit 1	Bit 2	Bit 3	Bit 4	Bit 5	Bit 6	Bit 7
1	201H	Bit 0	Bit 1	Bit 2	Bit 3	Bit 4	Bit 5	Bit 6	Bit 7
2	202H	Bit 0	Bit 1	Bit 2	Bit 3	Bit 4	Bit 5	Bit 6	Bit 7
3	203H	Bit 0	Bit 1	Bit 2	Bit 3	Bit 4	Bit 5	Bit 6	Bit 7
4	204H	Bit 0	Bit 1	Bit 2	Bit 3	Bit 4	Bit 5	Bit 6	Bit 7
5	205H	Bit 0	Bit 1	Bit 2	Bit 3	Bit 4	Bit 5	Bit 6	Bit 7
6	206H	Bit 0	Bit 1	Bit 2	Bit 3	Bit 4	Bit 5	Bit 6	Bit 7
7	207H	Bit 0	Bit 1	Bit 2	Bit 3	Bit 4	Bit 5	Bit 6	Bit 7
8	208H	Bit 0	Bit 1	Bit 2	Bit 3	Bit 4	Bit 5	Bit 6	Bit 7
9	209H	Bit 0	Bit 1	Bit 2	Bit 3	Bit 4	Bit 5	Bit 6	Bit 7
10	20AH	Bit 0	Bit 1	Bit 2	Bit 3	Bit 4	Bit 5	Bit 6	Bit 7
11	20BH	Bit 0	Bit 1	Bit 2	Bit 3	Bit 4	Bit 5	Bit 6	Bit 7
12	20CH	Bit 0	Bit 1	Bit 2	Bit 3	Bit 4	Bit 5	Bit 6	Bit 7
13	20DH	Bit 0	Bit 1	Bit 2	Bit 3	Bit 4	Bit 5	Bit 6	Bit 7
14	20EH	Bit 0	Bit 1	Bit 2	Bit 3	Bit 4	Bit 5	Bit 6	Bit 7
15	20FH	Bit 0	Bit 1	Bit 2	Bit 3	Bit 4	Bit 5	Bit 6	Bit 7
16	210H	Bit 0	Bit 1	Bit 2	Bit 3	Bit 4	Bit 5	Bit 6	Bit 7
17	211H	Bit 0	Bit 1	Bit 2	Bit 3	Bit 4	Bit 5	Bit 6	Bit 7
18	212H	Bit 0	Bit 1	Bit 2	Bit 3	Bit 4	Bit 5	Bit 6	Bit 7
19	213H	Bit 0	Bit 1	Bit 2	Bit 3	Bit 4	Bit 5	Bit 6	Bit 7
20	214H	Bit 0	Bit 1	Bit 2	Bit 3	Bit 4	Bit 5	Bit 6	Bit 7
21	215H	Bit 0	Bit 1	Bit 2	Bit 3	Bit 4	Bit 5	Bit 6	Bit 7
22	216H	Bit 0	Bit 1	Bit 2	Bit 3	Bit 4	Bit 5	Bit 6	Bit 7
23	217H	Bit 0	Bit 1	Bit 2	Bit 3	Bit 4	Bit 5	Bit 6	Bit 7
24	218H	Bit 0	Bit 1	Bit 2	Bit 3	Bit 4	Bit 5	Bit 6	Bit 7
25	219H	Bit 0	Bit 1	Bit 2	Bit 3	Bit 4	Bit 5	Bit 6	Bit 7
26	21AH	Bit 0	Bit 1	Bit 2	Bit 3	Bit 4	Bit 5	Bit 6	Bit 7
27	21BH	Bit 0	Bit 1	Bit 2	Bit 3	Bit 4	Bit 5	Bit 6	Bit 7
28	21CH	Bit 0	Bit 1	Bit 2	Bit 3	Bit 4	Bit 5	Bit 6	Bit 7
29	21DH	Bit 0	Bit 1	Bit 2	Bit 3	Bit 4	Bit 5	Bit 6	Bit 7
30	21EH	Bit 0	Bit 1	Bit 2	Bit 3	Bit 4	Bit 5	Bit 6	Bit 7
31	21FH	Bit 0	Bit 1	Bit 2	Bit 3	Bit 4	Bit 5	Bit 6	Bit 7
32	220H	Bit 0	Bit 1	Bit 2	Bit 3	Bit 4	Bit 5	Bit 6	Bit 7
33	221H	Bit 0	Bit 1	Bit 2	Bit 3	Bit 4	Bit 5	Bit 6	Bit 7
34	222H	Bit 0	Bit 1	Bit 2	Bit 3	Bit 4	Bit 5	Bit 6	Bit 7
35	223H	Bit 0	Bit 1	Bit 2	Bit 3	Bit 4	Bit 5	Bit 6	Bit 7
36	224H	Bit 0	Bit 1	Bit 2	Bit 3	Bit 4	Bit 5	Bit 6	Bit 7
37	225H	Bit 0	Bit 1	Bit 2	Bit 3	Bit 4	Bit 5	Bit 6	Bit 7
38	226H	Bit 0	Bit 1	Bit 2	Bit 3	Bit 4	Bit 5	Bit 6	Bit 7
39	227H	Bit 0	Bit 1	Bit 2	Bit 3	Bit 4	Bit 5	Bit 6	Bit 7

Note:

1. The LCD RAM address is allocated at page 2 of memory map. Only bit0 ~ bit3 is useful when it is 1/4 duty mode.
2. The LCD RAM can be **write & read** as like general purpose RAM.

16. Power Down Mode

The ST2016A has three power down modes: WAI-0, WAI-1 and STP. The instruction WAI will enable mode WAI-0 or WAI-1, which are controlled by WAIT(SYS[2]). The

instruction WAI (WAI-0 and WAI-1 modes) can be wake-up by interrupt. However, the instruction of STP can only be wake-up by hardware reset.

16.1 WAI-0 Mode:

When **WAIT** is cleared, WAI instruction lets MCU enter WAI-0 mode. In the mean time, oscillator circuit is be active and interrupts, timer/counter, and PSG will all be working. Under such circumstance, CPU stops and the related instruction execution will stop. All registers, RAM, and I/O pins will retain their states before the MCU enter standby mode. WAI-0 mode can be wake-up by reset or interrupt

request. If user disable interrupt(CPU register I='1'), MCU will still be wake-up but not go into the interrupt service routine. If interrupt is enabled(CPU register I='0'), the corresponding interrupt vector will be fetched and interrupt service routines will executed.

The sample program is showed as followed:

```
LDA #$00
STA SYS
WAI      ; WAI 0 mode
```

16.2 WAI-1 Mode:

When **WAIT** is set, WAI instruction let MCU to enter WAI-1 mode. In this mode, the CPU will stop, but PSG, basetimer/counter won't stop if the clock source is from OSCX. The wake-up procedure is the same as the one for

WAI-0. But the warm-up cycles are occur when WAI-1 wake-up.

The sample program is shown as the following:

```
LDA #$04
STA SYS
WAI      ; WAI 1 mode
```

16.3 STP Mode:

STP instruction will force MCU to enter stop mode. In this mode, MCU stops, but PSG, timer/counter won't stop if the clock source is from OSCX. In power-down mode, MCU only be wake-up by hardware reset, and the warm-up cycles are occur at the same time.

The sample program is showed as the following:

STP

TABLE 16-36: STATUS UNDER POWER DOWN MODE

(SYSCK source from OSC)

Mode	Timer0,1	SYSCK	OSC	OSCX	Base Timer	RAM	REG.	LCD	I/O	Wake-up condition
WAI-0	Retain									Reset, Any interrupt
WAI-1	Stop	Stop	Stop	Retain						Reset, Any interrupt
STP	Stop	Stop	Stop	Retain						Reset

(SYSCK source from OSCX)

Mode	Timer0,1	SYSCK	OSC	OSCX	Base Timer	RAM	REG.	LCD	I/O	Wake-up condition
WAI-0	Retain									Reset, Any interrupt
WAI-1	Stop	Stop	Retain							Reset, Any interrupt
STP	Stop	Stop	Retain							Reset

17. Electrical Characteristics

DC Supply Voltage ----- -0.3V to +7.0V
 Operating Ambient Temperature ----- -10°C to +60°C
 Storage Temperature ----- -10°C to +125°C

***Notice:** Stresses above those listed under "Absolute Maximum Ratings" may cause permanent damage to the device. All the ranges are stress ratings only. Functional operation of this device at these or any other conditions above those indicated in the operational sections of this specification is not implied or intended. Exposed to the absolute maximum rating conditions for extended periods may affect device reliability.

17.1 DC Electrical Characteristics

Standard operation conditions: $V_{DD} = 3.0V$, $GND = 0V$, $T_A = 25^\circ C$, $OSC = 4M\ Hz$, $OSC_X = 32768\ Hz$, unless otherwise specified

Parameter	Symbol	Min.	Typ.	Max.	Unit	Condition
Operating Voltage	V_{DD}	2.4	3	3.6	V	
Operating Current	I_{OP}		870	1300	μA	All output pins unload, execute NOP instruction, LCD on
Standby Current 1	I_{SB1}		0.5	1	μA	All output pins unload, OSCX off, LCD off (WAIT1/STOP mode)
Standby Current 2	I_{SB2}		3	4.5	μA	All output pins unload, OSCX on, LCD off (WAIT1/STOP mode)
Standby Current 3	I_{SB3}		87	130	μA	All output pins unload, OSCX on, LCD off (WAIT0 mode)
Input High Voltage	V_{IH}	0.7 V_{DD} 0.85 V_{DD}	-	$V_{DD} + 0.3$	V	PORT A, PORT B, PORT C, PORT D Reset, \overline{INT}
			-		V	
Input Low Voltage	V_{IL}	GND -0.3	-	0.3 V_{DD} 0.15 V_{DD}	V	PORT A, PORT B, PORT C PORT D Reset, \overline{INT}
			-		V	
Pull-up resistance	R_{OH}		150		K Ω	PORTA, PORTB PORT C ($I_{OH}=0.7V_{dd}$).
LCD Ron resistance	L_{ron}	460	500	540	Ω	
Port A,B output high voltage	V_{OH1}	0.7 V_{DD}	-		V	PORTA, PORTB PORT C ($I_{OH} = -3.5mA$).
Port A,B output low voltage	V_{OL1}			0.3 V_{DD}	V	PORTA, PORTB PORT C ($I_{OL} = 8.5mA$).
Output high voltage	V_{OH2}	0.7 V_{cc}			V	PSG/DAC, $I_{OH} = -30mA$.
Output low voltage	V_{OL2}			0.3 V_{cc}	V	PSG/DAC, $I_{OL} = 45mA$.
COM output low voltage	V_{OL3}			0.3 V_{DD}	V	COM[4~7], $I_{OL} = 3.3mA$.
OSCX start time	T_{STT}	-	1	3	s	
Frequency stability	$\Delta F / F$			1	PPM	$[F(3.0)-F(2.5)]/F(3.0)$ (crystal oscillator)
Frequency variation	$\Delta F / F$	-10	3	10	PPM	C1= 15 – 30P.

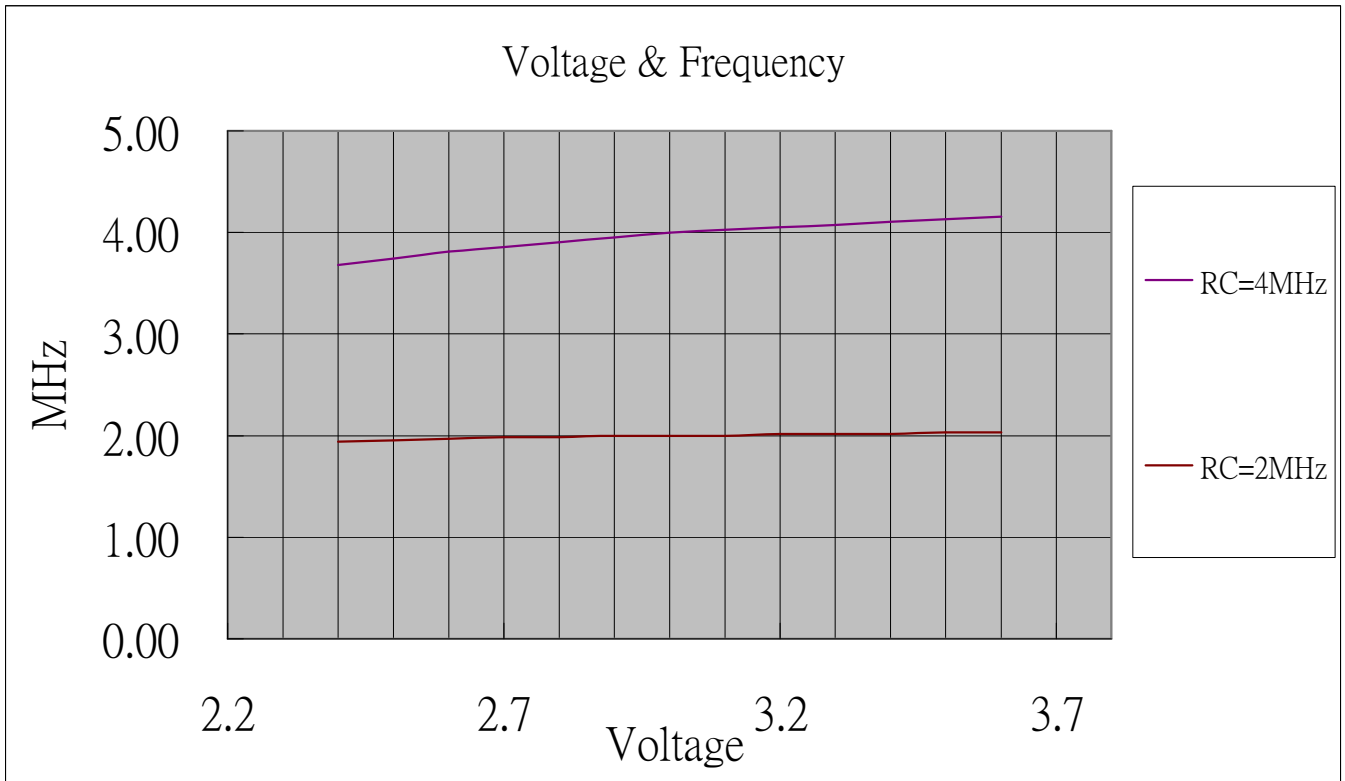

FIGURE 17-29: Relation between operation voltage & frequency

TABLE 17-37: OSCI Resistance to OSC Frequency mapping table

OSCI Resistance	OSC Frequency
185KΩ	4MHz
442KΩ	2MHz
965KΩ	1MHz
2080KΩ	0.5MHz

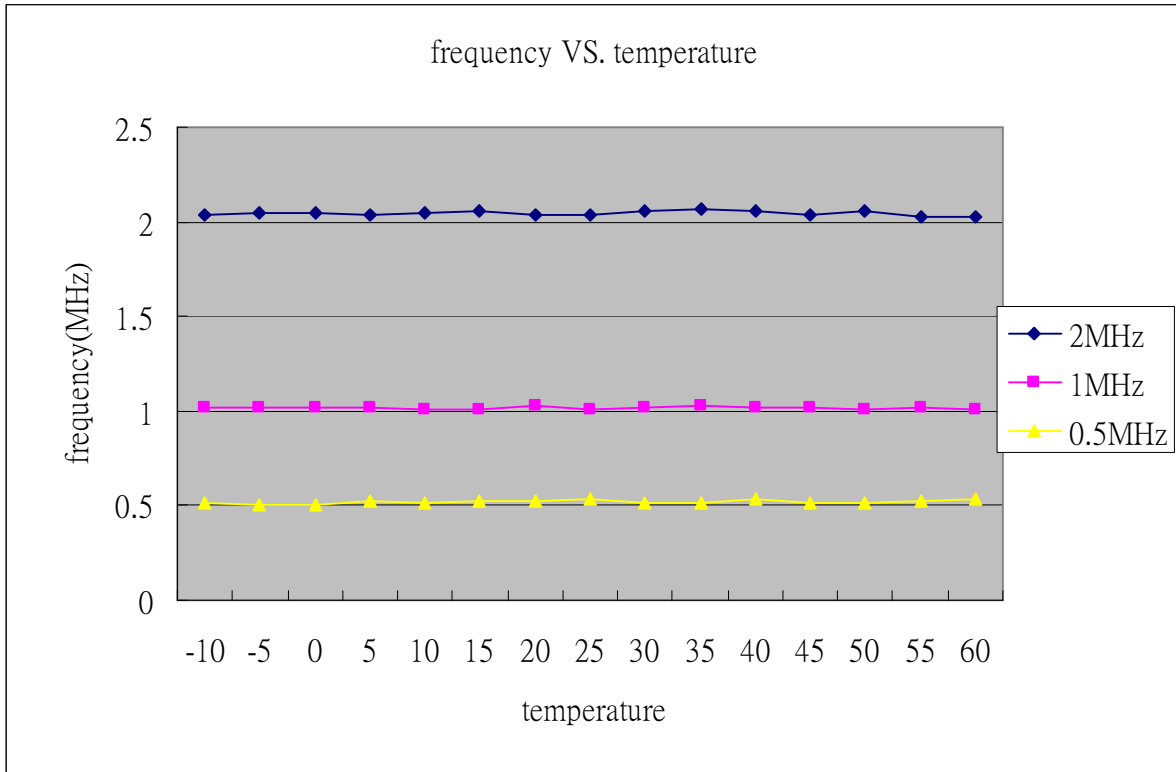

FIGURE 17-30: Frequency VS. Temperature

18. Application Circuits

18.1 APPLICATION CIRCUIT UNDER 3V OPERATING VOLTAGE

VDD : 3V
 Clock : 32768Hz crystal and 4.0MHz RC oscillator
 LCD : 1/8 duty
 I/O : PORT A
 ALARM : PSGO, PSGOB

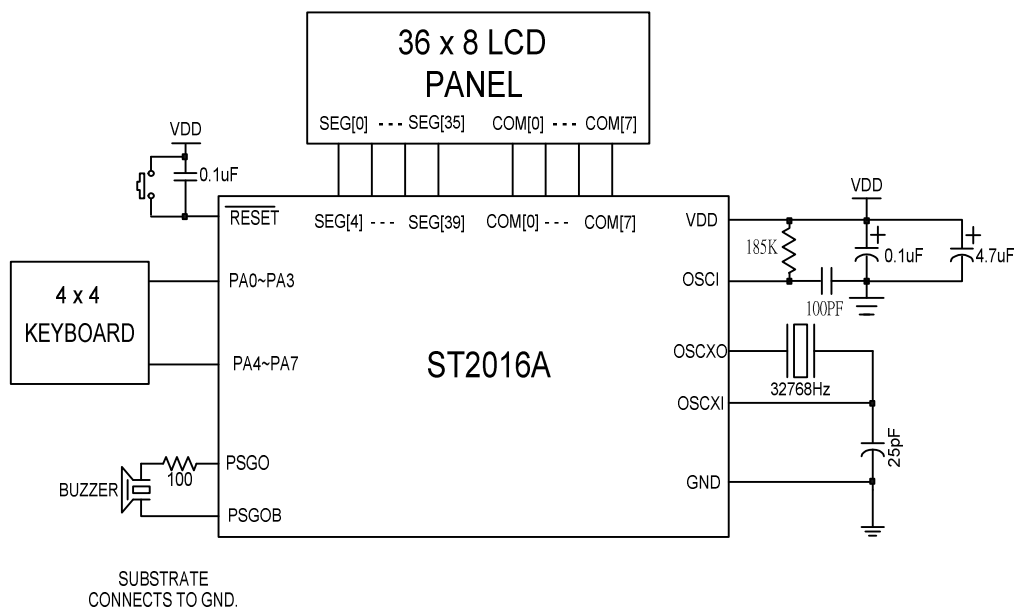

FIGURE 18-31: APPLICATION CIRCUIT WITHOUT LCD KEYBOARD AWAKING PULSE

VDD : 3V
 Clock : 32768Hz crystal and 4.0MHz RC oscillator
 LCD : 1/8 duty
 I/O : PORT A
 ALARM : PSG0, PSG1

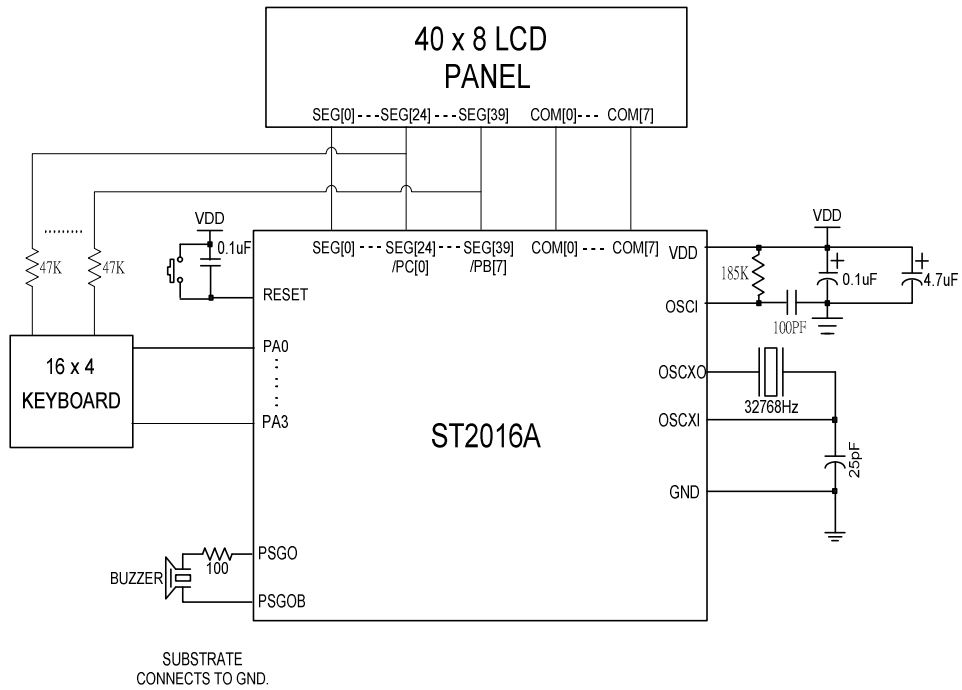

FIGURE 18-32: APPLICATION CIRCUIT WITH LCD KEYBOARD AWAKING PULSE

Note:

1. COMs and SEGs output GND level, while the LCD is turned off.
2. If LCD is turned off, Keyboard Awakening Pulses must be turned off at the same time.
3. Connect one capacitor of 100PF to OSCI stabilize oscillation frequency. This capacitor must be placed close to OSCI.

ST2016A EVB PCB108

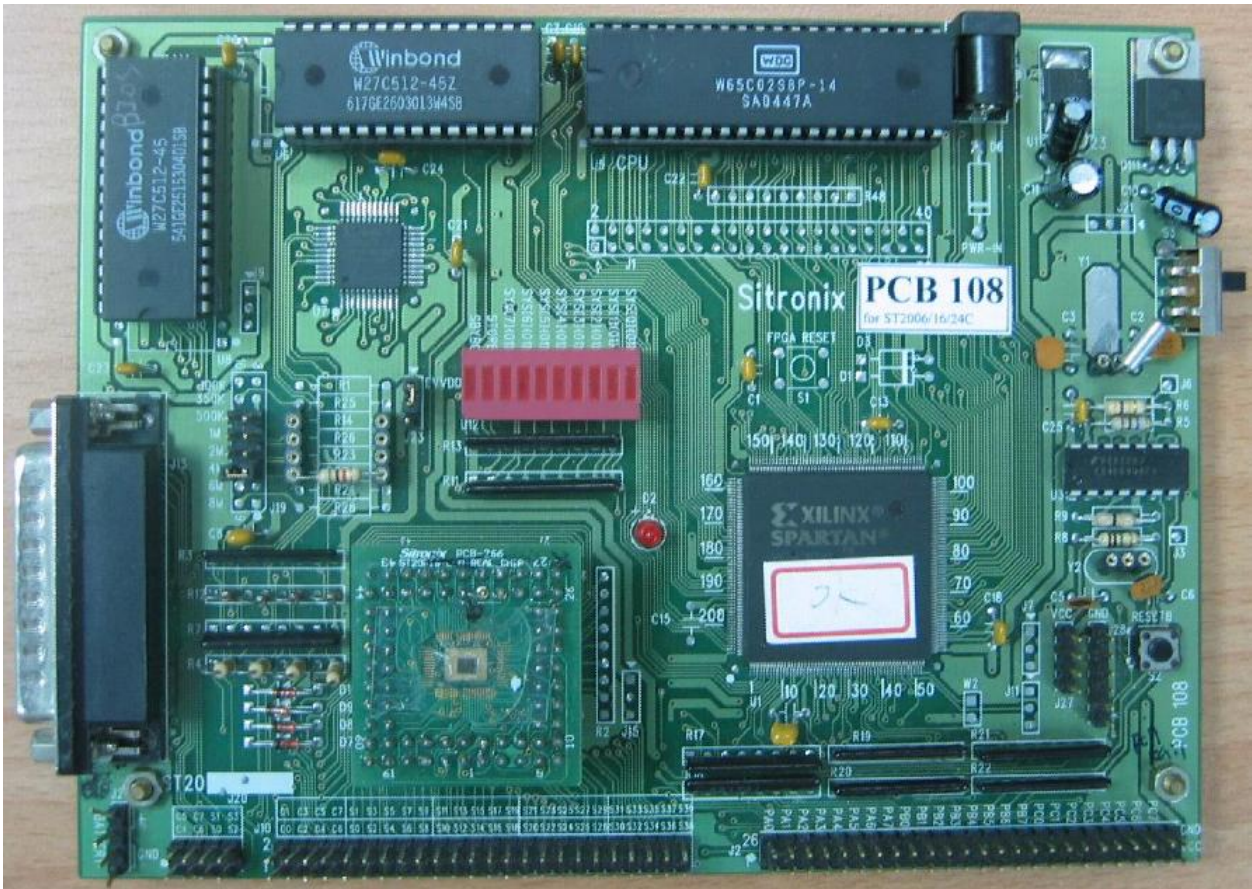

FIGURE 18-33: The PCB 108 of ST2016A EVB

Project name _____ / _____ / _____

	Confirmed Item	Check	Note
1	After power on , initial user RAM and confirm control register .		
2	Confirm LCD panel's V_{OP} (contrast level) 、 Duty and Bias .		
3	Confirm the difference between E.V. Board and real chip (ex. V_{OP} 、 driving strength 、 F_{OSC} 、 power consumption 、 noise...etc.)		
4	Before entry power down mode , turn off un-used peripheral. (LCD driver 、 PSG 、 OSC or OSCX)		
5	Make sure power down mode work .		
6	Calculate average operating current . (Wake up time ratio)		
7	Confirm I/O directions and set pull-up for un-used input pins .		
8	For input mode with pull-up function , Please set bit 7 of port condition control register (PMCR[7]) and each bit of port data register .		
9	If use I/O for pin option , please re-configure I/O status after reading . (directions and pull-up resistor)		
10	Pay attention to "bit instructions" , because some registers have different function for read and write acting. ex. PA 、 PB 、 PRS 、 SYS and control register for write only .		
11	Disable un-used function's control register and put "RTI" Instruction at un-used interrupt vector .		
12	Make sure timer counting correct .		
13	Make sure temperature counting correct .		
14	Make sure software key de-bounce work . (10 ~ 50 mS)		
15	Make sure calendar counting correct . (include user setting)		
16	Make sure stack memory will not overflow .		
17	Under test mode , every functions / parts must be tested . ex. LCD 、 LED 、 speaker / buzzer 、 key 、 motor and senser...etc.		
18	Please use same parts when developing and producing .		
19	Please select general parts for production.		
20	When testing , write every unusual situation down and find out the reasons indeed.		
21	Make sure the program accept un-normal operatings and system will not hold or crash down .		
23	When you set I/O port as input mode , please make sure signal level stable before reading . ex. When key scan , please delay 12 uS then get key code .		
24	Make sure LCD contrast is controlled by LCTL[3~0].		
25	If Port-A want to be read or set to output, Dynamic I/O function must be disable(PAK[7:0]=0) and wait 12 uS to stable.		
26	Make sure resister of R-OSC on EV-Chip matches desired frequency and equals the crytal on EV-Board.		
27	If LCD clock source is from R-OSC, LCD will have no clock in WA11 and can't display.		
28	Always disable interrupt function(by an " SEI " instruction) when modify the IENAL, IENAH, IREQL and IREQH register		
29	After Power on , enter wait 0 mode 0.5s before normal operation		

Special Notice

Confirmed Item		Check	Note
Special Notice 1 (If the LCD keyboard awaking pulses function was turned on)			
1	If two keys be pressed at the same time affect LCD display must be reduced. One resister(47K) should be added between scan line and keyboard, And selecting the LCD driving strength to maximum during the keys were pressed.		
2	When LCD is turned off, please disable Keyboard Awaking Pulses at the same time.		
3	If both the HW debounce and LCD keyboard awaking pulses are enabled, LCD keyboard awaking pulses must be disabled before latch Port-A. <div style="margin-left: 100px;"> rmb4 <LCTL lda <PA smb4 <LCTL </div>		
Special Notice 2			
1	Do not use 32768HZ as system clock		

Engineer _____ Manger _____

Application Circuit :

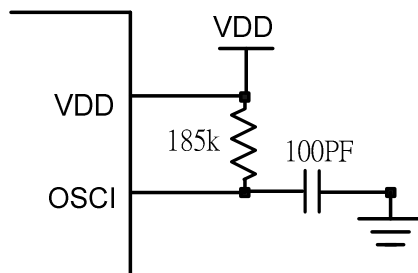

Note:
 Connect one capacitor of 100PF to OSCI stabilize oscillation frequency.
 This capacitor must be placed close to OSCI.

19. REVISION

Version2.8	Page 51 Page 57 Page21	Add Figure of Frequency VS. Temperature Add system clock regulation in Special Notice 2 Modify SYS [XSEL] in Table of SYSTEM CONTROL REGISTER (SYS).....	2007/09/12
Version2.7	Page23 Page52 Page53	Modify description figure 11-6 to 12-7. Add PCB 108 of ST2016A EVB photo Add checklist for customer to confirm ST2016A EVB PCB number	2007/5/21
Version2.6	Page53	Modify checklist Port-A[4~7] Option that CMOS output to I/O	2006/8/7
Version2.5	Page9,21,22 Page41, Page48, Page54,	Change register SYS bit4 XBAK to Test bit and must be set "0" Modify driving strength level 1~32 in heavy mode Modify standby current 1,3 in heavy mode Remove Item 28 normal mode in checklist	2006/8/1
Version2.4	Page1	Add CPU clock 250K ~ 2M Hz	2006/06/23
Version2.3	Page50,51,55 Page55	modify OSC1 external resistor Value 180k to 185k Add checklist item 30=>after Power on ,enter wait 0 mode 0.5s before normal operation	2006/5/5
Version2.2	Page20 Page48 Page52/53/54	modify COM[4~7] output =FLOATING modify oscillation time to OSCX Heavy start time add checklist	2006/2/8
Version 2.1	Page 1 Page 32/33 Page35 Page12	remove IR remote controller take off PSG/DAC clock source from oscx modify Two-Pin Two Ended Mode Application Circuit add pad number and note: all of unused input pins should be pulled up to minimize standby current.....	2005/11/8
Version2.0	Page 48	Add PSG driving and sinking current in DC Characteristic	2005/9/26
Version 1.9:	Page 32	Modify PSGCK selection	2005/8/17
Version 1.8:	Page 27/30 Page 9/11/13/22 Page 9/22 Page 40 Page 40	Remove PSG clock source from OSCX Modify IREQ(\$3C) value 3B=>?? Modify PRS(\$23) Read value 00=>FF Add Pad Definition Modify register LSEL(\$39) default value 00=>9F	2005/6/15
Version 1.7:	Page 9/21/42/43	Modifying "LCTL" Write only to read available	2004/6/23
Version 1.6:	Page 21 Page 41	OSCX work under heavy load mode to support more kinds of 32KHz crystals Add one note about LCD display quality	2004/4/7
Version 1.5:	Page 42 Page 46 Page 48	Modifying LCD driving level (0 to 1, 31 to 32). Modifying process to latch port-A in interrupt service routing. Modifying WAI1 mode description(timer to basetime)	2004/2/17
Version 1.4:	Page 8 Page 47	Modifying Memory mapping diagram. Modifying example code and flow chart	2003/11/03

Version 1.3:		
Page 51/52	Modifying Reset pin connect a switch to VDD in Application Circuit	2003/8/22
Version 1.2:		
Page 42	Adding the Measure Condition on TABLE 15-33:	
Page 49	Modifying the DC Characteristic	
Page 51/52	Modifying the Application Circuit (1000P → 100P).....	2003/8/4
Version 1.1:		
Page 1	Modifying operation voltage range..	
Page 5	Fill pad description	2003/7/8
Version 1.0:		
Page 19	Modifying the description of Port-D.	
Page 43	Fill LCD Power Consumption.	
Page 50	Fill electrical characteristic table .	
Page 51	Add FIGURE 17-29: & TABLE 17-37:	2003/7/4
Version 0.4:		
Page 48/49	Modifying FIGURE 18-31: /FIGURE 18-32: and note.	
Version 04:		
Page 3	Adding Pad Diagram.	
Page 19	Modifying TABLE 10-17: (SCAN) to (COM).	
Page 49/50	Modifying FIGURE 18-31: /FIGURE 18-32: and note	
Page 51	Adding Pad Location	2003/1/29
Version 03:		
Page 27	Adding TABLE 13-25: to describe register "PSGC2"	
Page 43	Modifying example for using keyboard scan function.	
Page 12	Adding register "PAK" description.	
Page 19	Adding exposition of port-D.	
Page 41	Modifying the LCD source clock table	2002/12/9
Version 0.2:		
Page 40	Modifying the driving strength table	2002/10/29
Version 0.1:		
.....		2002/10/1

The above information is the exclusive intellectual property of Sitronix Technology Corp. and shall not be disclosed, distributed or reproduced without permission from Sitronix. Sitronix Technology Corp. reserves the right to change this document without prior notice and makes no warranty for any errors which may appear in this document. Sitronix products are not intended for use in life support, critical care, medical, safety equipment, or similar applications where products failure could result in injury, or loss of life, or personal or physical harm, or any military or defense application, or any governmental procurement to which special terms or provisions may apply.