



ILI9881C-0D

Amorphous TFT LCD Single-Chip Driver 800(RGB) x 1280 Resolution, 16.7M-color Without Internal GRAM

Specification

Version: V102

Document No: ILI9881C-0D_DTS_V102_20170316_Normal

ILI TECHNOLOGY CORP.

8F, No. 38, Taiyuan St, Jhubei City,
Taiwan 302, R.O.C.
Tel.886-3-5600099; Fax.886-3-5600585
<http://www.ilitek.com>

Table of Contents

1. INTRODUCTION	17
2. FEATURES	18
3. DEVICE OVERVIEW	20
3.1. BLOCK DIAGRAM	20
3.2. BLOCK FUNCTION DESCRIPTION	21
3.2.1. System Interface	21
3.2.2. Grayscale Voltage Generating Circuit	21
3.2.3. TCON	21
3.2.4. OSC	21
3.2.5. RAM	21
3.2.6. Source Driver Circuit	21
3.2.7. Gate Controller Circuit	21
3.2.8. DC-to-DC Power Supply Circuit	21
3.2.9. CABC (Content Adaptive Brightness Control)	21
3.3. PIN DESCRIPTIONS	22
3.4. PIN ASSIGNMENT	26
3.5. BUMP ARRANGEMENT	27
3.6. PAD COORDINATION	30
4. SYSTEM INTERFACE	38
4.1. DSI SYSTEM INTERFACE	38
4.1.1. General Description	38
4.1.2. Interface Level Communication	40
4.1.2.1. General	40
4.1.2.2. DSI CLK Lanes	41
4.1.2.2.1. Low Power Mode (LPM)	41
4.1.2.2.2. Ultra-Low Power Mode (ULPM)	43
4.1.2.2.3. High-Speed Clock Mode (HSCM)	44
4.1.2.3. DSI Data Lanes	47
4.1.2.3.1. General	47
4.1.2.3.2. Escape Modes	47
4.1.2.3.2.1. Low-Power Data Transmission (LPDT)	49
4.1.2.3.2.2. Ultra-Low Power State (ULPS)	50
4.1.2.3.2.3. Remote Application Reset (RAR)	51
4.1.2.3.2.4. Acknowledge (ACK)	52
4.1.2.3.3. High-Speed Data Transmission (HSDT)	53
4.1.2.3.3.1. Entering High-Speed Data Transmission (TSOT of HSDT)	53

4.1.2.3.3.2.	Leaving High-Speed Data Transmission (TEOT of HSDT).....	54
4.1.2.3.3.3.	Burst of the High-Speed Data Transmission (HSDT).....	55
4.1.2.3.4.	Bus Turnaround (BTA)	59
4.1.3.	<i>Packet Level Communication</i>	60
4.1.3.1.	Short Packet (SPa) and Long Packet (LPa) Structures	60
4.1.3.1.1.	Bit Order of the Byte on Packets	61
4.1.3.1.2.	Byte Order of the Multiple Byte Information on Packets.....	61
4.1.3.1.3.	Packet Header (PH)	62
4.1.3.1.3.1.	Data Identification (DI).....	63
4.1.3.1.3.1.1.	Virtual Channel (VC)	63
4.1.3.1.3.1.2.	Data Type (DT).....	64
4.1.3.1.3.2.	Packet Data (PD) in a Short Packet (SPa)	66
4.1.3.1.3.3.	Word Count (WC) in a Long Packet (LPa).....	68
4.1.3.1.3.4.	Error Correction Code (ECC).....	69
4.1.3.1.4.	Packet Data (PD) in a Long Packet (LPa).....	73
4.1.3.1.5.	Packet Footer (PF) in a Long Packet (LPa).....	73
4.1.3.2.	Packet Transmissions.....	75
4.1.3.2.1.	Packet from the MCU to the Display Module.....	75
4.1.3.2.1.1.	Display Command Set (DCS)	75
4.1.3.2.1.2.	Display Command Set (DCS) Write, No Parameter (DCSWN-S)	76
4.1.3.2.1.3.	Display Command Set (DCS) Write, 1 Parameter (DCSW1-S).....	77
4.1.3.2.1.4.	Display Command Set (DCS) Write Long (DCSW-L).....	78
4.1.3.2.1.5.	Display Command Set (DCS) Read, No Parameter (DCSRN-S).....	82
4.1.3.2.1.6.	Null Packet, No Data (NP-L)	85
4.1.3.2.1.7.	End of Transmission Packet (EoTP)	87
4.1.3.2.2.	Packet from the Display Module to the MCU.....	89
4.1.3.2.2.1.	Used Packet types.....	89
4.1.3.2.2.2.	Acknowledge with Error Report (AwER)	90
4.1.3.2.2.3.	DCS Read Long Response (DCSRR-L)	92
4.1.3.2.2.4.	DCS Read Short Response, 1 Byte Returned (DCSRR1-S)	94
4.1.3.2.2.5.	DCS Read Short Response, 2 Bytes Returned (DCSRR2-S).....	95
4.1.3.3.	Communication Sequences	96
4.1.3.3.1.	General.....	96
4.1.3.3.2.	Sequences	98
4.1.3.3.2.1.	DCS Write, 1 Parameter Sequence.....	98
4.1.3.3.2.2.	DCS Write, No Parameter Sequence.....	99
4.1.3.3.2.3.	DCS Write Long Sequence.....	100
4.1.3.3.2.4.	DCS Read, No Parameter Sequence.....	101
4.1.3.3.2.5.	Null Packet, No Data Sequence.....	103

4.1.3.3.2.6.	End of Transmission Packet	103
4.1.3.4.	16 bit / pixel Writing	104
4.1.3.5.	24 bit/pixel Writing	106
4.2.	DISPLAY DATA FORMAT	108
4.2.1.	<i>DSI Transmission Data Format</i>	108
4.2.1.1.	16-bit per Pixel, Long Packet, Data Type 00 1110 (0Eh)	108
4.2.1.2.	18-bit per Pixel, Long Packet, Data Type = 01 1110 (1Eh)	108
4.2.1.3.	18-bit per Pixel, Long Packet, Data Type = 10 1110 (2Eh)	109
4.2.1.4.	24-bit per Pixel, Long Packet, Data Type = 11 1110 (3Eh)	110
4.2.2.	<i>16/18-bit Color Data Mapping to 24-bit Pixel Data Operation</i>	112
5.	COMMAND	114
5.1.	COMMAND FLOW	114
5.2.	COMMAND LIST	115
5.2.1.	<i>Page 0 Command Set</i>	115
5.2.2.	<i>Page 1 Command Set</i>	117
5.2.3.	<i>Page 2 Command Set</i>	119
5.2.4.	<i>Page 3 Command Set</i>	120
5.2.5.	<i>Page 4 Command Set</i>	121
5.2.6.	<i>Page 5 Command Set</i>	123
5.2.7.	<i>Page 6 Command Set</i>	123
5.2.8.	<i>Page 7 Command Set</i>	124
5.2.9.	<i>Page 8 Command Set</i>	124
5.2.10.	<i>Page 9 Command Set</i>	125
5.2.11.	<i>Page 10 Command Set</i>	125
5.3.	PAGE 0 COMMAND DESCRIPTION	126
5.3.1.	<i>NOP (00h)</i>	126
5.3.2.	<i>Software Reset (01h)</i>	127
5.3.3.	<i>Read Number of the Errors on DSI (05h)</i>	128
5.3.4.	<i>Read Display Status (09h)</i>	129
5.3.5.	<i>Read Display Power Mode (0Ah)</i>	131
5.3.6.	<i>Read Display MADCTL (0Bh)</i>	132
5.3.7.	<i>Read Display Pixel Format (0Ch)</i>	133
5.3.8.	<i>Read Display Image Mode (0Dh)</i>	134
5.3.9.	<i>Read Display Signal Mode (0Eh)</i>	135
5.3.10.	<i>Read Display Self-Diagnostic Result (0Fh)</i>	136
5.3.11.	<i>Sleep In (10h)</i>	137
5.3.12.	<i>Sleep Out (11h)</i>	138
5.3.13.	<i>Normal Display Mode On (13h)</i>	139

5.3.14.	All Pixel Off (22h)	140
5.3.15.	All Pixel On (23h).....	141
5.3.16.	Gamma Set (26h).....	142
5.3.17.	Display Off (28h).....	143
5.3.18.	Display ON (29h).....	144
5.3.19.	Memory Write (2Ch).....	145
5.3.20.	Tearing Effect Line Off (34h).....	146
5.3.21.	Tearing Effect Line On (35h).....	147
5.3.22.	Memory Access Control (36h).....	149
5.3.23.	Idle Mode Off (38h).....	151
5.3.24.	Idle Mode On (39h).....	152
5.3.25.	Interface Pixel Format (3Ah).....	153
5.3.26.	Memory Write Continue (3Ch).....	154
5.3.27.	Set_Tear_Scanline (44h).....	155
5.3.28.	Get_Tear_Scanline (45h).....	156
5.3.29.	Write Display Brightness Value (51h).....	157
5.3.30.	Read Display Brightness Value (52h).....	158
5.3.31.	Write CTRL Display Value (53h).....	159
5.3.32.	Read CTRL Display Value (54h).....	160
5.3.33.	Write Power Save (55h).....	161
5.3.34.	Read Power Save (56h).....	162
5.3.35.	Stop Transition (59h).....	163
5.3.36.	Write CABC Minimum Brightness (5Eh).....	164
5.3.37.	Read CABC Minimum Brightness (5Fh).....	165
5.3.38.	Set Transition Time (68h).....	166
5.3.39.	Get Transition Time (69h).....	168
5.3.40.	Write Idle Mode Color (80h).....	170
5.3.41.	Read Idle Mode Color (81h).....	171
5.3.42.	Read DDB Start (A1h).....	172
5.3.43.	Read DDB Continue (A8h).....	174
5.3.44.	Read First Checksum (AAh).....	175
5.3.45.	Read Continue Checksum (AFh).....	176
5.3.46.	Read ID1 (DAh).....	177
5.3.47.	Read ID2 (DBh).....	178
5.3.48.	Read ID3 (DCh).....	179
5.3.49.	EXTC Command Set Enable Register (FFh).....	180
5.4.	PAGE 1 COMMAND DESCRIPTION.....	181
5.4.1.	Read ID4 (00h~02h).....	181
5.4.2.	Set Panel Operation Mode and Data Complement Setting (22h).....	182

5.4.3.	Blanking Porch Control (25h~26h).....	183
5.4.4.	Touch Synchronization Control (29h)	184
5.4.5.	Gate Number (2Eh).....	185
5.4.6.	Display Inversion Control (31h).....	186
5.4.7.	Dithering Enable (34h).....	188
5.4.8.	Pump Clock Adjustment (40h~43h)	189
5.4.9.	Power Control 1 (50h~51h).....	191
5.4.10.	VCOM Control 1 (52h~56h).....	193
5.4.11.	Entry Mode Set (58h).....	195
5.4.12.	Source Timing Adjust (60h~63h).....	196
5.4.13.	Positive Gamma Correction (A0h~B3h)	197
5.4.14.	Pad Control (B6h~B7h)	198
5.4.15.	Negative Gamma Correction (C0h~D3h)	199
5.4.16.	NV Memory Write (E0h~E2h)	200
5.4.17.	NV Memory Protection Key (E3h~E5h)	201
5.4.18.	NV Memory Status Read (E6h~E9h)	202
5.4.19.	Time Stamp (F0h~F1h).....	204
5.4.20.	EXTC Command Set Enable Register (FFh).....	205
5.5.	PAGE 2 COMMAND DESCRIPTION.....	206
5.5.1.	Dynamic Backlight Control 1 (03h~05h)	206
5.5.2.	Dynamic Backlight Control 2 (06h~07h)	207
5.5.3.	IIE Function Control (10h~19h).....	208
5.5.4.	IIE Saturation Enhancement Control 1 (1Ah~1Ch).....	210
5.5.5.	IIE Saturation Protection Control (40h~4Fh).....	211
5.5.6.	IIE Sharpness Enhancement Control (5Ah~5Ch)	213
5.5.7.	IIE Contrast Enhancement Control (60h~66h)	214
5.5.8.	EXTC Command Set Enable Register (FFh).....	215
5.6.	PAGE 3 COMMAND DESCRIPTION.....	216
5.6.1.	EXTC Command Set Enable Register (FFh).....	216
5.7.	PAGE 4 COMMAND DESCRIPTION.....	217
5.7.1.	DSI Lanes Control (00h)	217
5.7.2.	SSC Function (0Bh,0Eh).....	218
5.7.3.	Charge-Pump Setting (21h)	219
5.7.4.	Idle Mode Frame Rate (23h).....	220
5.7.5.	Internal SD Timing Control (26h).....	221
5.7.6.	Touch Synchronization Timing Adjust (27h~2Ah).....	222
5.7.7.	BIST Mode Function (2Dh,2Fh)	224
5.7.8.	Source Timing Setting (35h)	225
5.7.9.	Power Saving Control (3Ah).....	226

5.7.10.	Power Control 1 (69h).....	227
5.7.11.	Power Control 2 (6Eh).....	228
5.7.12.	Power Control 3 (6Fh).....	229
5.7.13.	VREG1/2 Setting (7Ah).....	231
5.7.14.	LVD Function 1 (87h).....	232
5.7.15.	LVD Function 2 (88h).....	233
5.7.16.	VCOM Control (8Bh).....	234
5.7.17.	Power Control 4 (8Ch~8Dh).....	235
5.7.18.	Reload Gamma Setting (B2h).....	237
5.7.19.	Gamma Bias Level (B5h).....	238
5.7.20.	Temperature Detecting Setting 1 (BBh~C2h).....	239
5.7.21.	Read VCOM OTP Data (C4h~C7h).....	241
5.7.22.	Temperature Detecting Setting 2 (C8h~CEh).....	242
5.7.23.	OTP Control (D7h).....	243
5.7.24.	EXTC Command Set Enable Register (FFh).....	244
5.8.	PAGE 5 COMMAND DESCRIPTION.....	245
5.8.1.	Fine Digital Gamma Control 1 (00h~7Fh).....	245
5.8.2.	Digital 3 Gamma Enable (80h).....	247
5.8.3.	EXTC Command Set Enable Register (FFh).....	248
5.9.	PAGE 6 COMMAND DESCRIPTION.....	249
5.9.1.	Fine Digital Gamma Control 2 (00h~7Fh).....	249
5.9.2.	EXTC Command Set Enable Register (FFh).....	251
5.10.	PAGE 7 COMMAND DESCRIPTION.....	252
5.10.1.	Fine Digital Gamma Control 3 (00h~7Fh).....	252
5.10.2.	EXTC Command Set Enable Register (FFh).....	254
5.11.	PAGE 8 COMMAND DESCRIPTION.....	255
5.11.1.	Fine Digital Gamma Control 4 (00h~7Fh).....	255
5.11.2.	EXTC Command Set Enable Register (FFh).....	257
5.12.	PAGE 9 COMMAND DESCRIPTION.....	258
5.12.1.	Fine Digital Gamma Control 5 (00h~7Fh).....	258
5.12.2.	EXTC Command Set Enable Register (FFh).....	260
5.13.	PAGE 10 COMMAND DESCRIPTION.....	261
5.13.1.	Fine Digital Gamma Control 6 (00h~7Fh).....	261
5.13.2.	EXTC Command Set Enable Register (FFh).....	263
6.	SOURCE DRIVER.....	264
6.1.	ZIG-ZAG INVERSION.....	264
6.2.	ZIG-ZAG INVERSION CONCEPT.....	265
6.3.	ZIG-ZAG INVERSION SOURCE OUTPUT METHOD.....	266

6.4.	ZIG-ZAG INVERSION RED DATA DISPLAY.....	267
6.5.	ZIG-ZAG INVERSION GREEN DATA DISPLAY	268
6.6.	ZIG-ZAG INVERSION BLUE DATA DISPLAY	269
6.7.	DIFFERENT ZIG-ZAG TYPE PANEL	270
7.	ENTER/EXIT IDLE MODE FLOW	272
7.1.	ENTER/EXIT IDLE MODE FLOW	272
7.2.	ENTER/EXIT IDLE MODE SEQUENCE	273
8.	BIST MODE FUNCTION	274
8.1.	BIST MODE PATTERN	274
9.	CONTENT ADAPTIVE BRIGHTNESS CONTROL (CABC) FUNCTION	275
10.	COLOR ENHANCEMENT FUNCTION.....	276
10.1.	SATURATION ENHANCEMENT	276
10.2.	CONTRAST ENHANCEMENT	277
10.3.	SHARPNESS ENHANCEMENT	278
10.4.	SUNLIGHT READABILITY	279
11.	SLEEP OUT COMMAND AND SELF-DIAGNOSTIC FUNCTIONS	280
11.1.	REGISTER LOADING DETECTION.....	280
11.2.	FUNCTIONALITY DETECTION	281
12.	POWER ON/OFF SEQUENCE	282
12.1.	POWER ON/OFF SEQUENCE	282
12.1.1.	Power Mode 2A	282
12.1.2.	Power Mode 3.....	283
12.1.3.	Power Mode 4.....	284
12.2.	UNCONTROLLED POWER OFF	285
13.	POWER LEVEL DEFINITION	286
13.1.	POWER LEVELS	286
13.2.	POWER FLOW CHART.....	286
14.	CHARACTERISTICS OF I/O	287
14.1.	OUTPUT OR BI-DIRECTIONAL (I/O) PINS.....	287
14.2.	INPUT PINS	287
15.	NV MEMORY PROGRAMMING FLOW	288
15.1.	EXTERNAL MTP_PWR PROGRAMMING FLOW	288
15.2.	INTERNAL VGH PROGRAMMING FLOW	289

16.	GAMMA CORRECTION	290
17.	TOUCH SYNCHRONIZATION SIGNAL	291
18.	ELECTRICAL CHARACTERISTICS	292
18.1.	ABSOLUTE MAXIMUM RATINGS	292
18.2.	DC CHARACTERISTICS FOR PANEL DRIVING.....	293
18.3.	DSI DC CHARACTERISTICS	294
18.3.1.	<i>DC Characteristics for DSI LP Mode</i>	294
18.3.2.	<i>Spike/Glitch Rejection</i>	295
18.3.3.	<i>DC Characteristics for DSI HS mode</i>	296
18.4.	AC CHARACTERISTICS.....	299
18.4.1.	<i>DSI Timing Characteristics</i>	299
18.4.2.	<i>High Speed Mode – Clock Channel Timing</i>	299
18.4.3.	<i>High Speed Mode – Data Clock Channel Timing</i>	300
18.4.4.	<i>High Speed Mode – Rising and Falling Timings</i>	301
18.4.5.	<i>Low Speed Mode – Bus Turn Around</i>	302
18.4.6.	<i>Data Lanes from Low Power Mode to High Speed Mode</i>	303
18.4.7.	<i>Data Lanes from High Speed Mode to Low Power Mode</i>	304
18.4.8.	<i>DSI Clock Burst – High Speed Mode to/from Low Power Mode</i>	305
18.4.9.	<i>Timing for DSI video mode</i>	306
18.4.10.	<i>Reset Timing</i>	308
19.	PANEL APPLICATION	309
19.1.	INPUT POWER TYPE.....	309
19.2.	POWER MODE 2A (BOOSTM[2:0] = 1H, DI_PWR_REG = 0H)	310
19.2.1.	<i>Power Structure</i>	310
19.2.2.	<i>Reference Circuit</i>	311
19.2.3.	<i>External Component</i>	312
19.3.	POWER MODE 3 (BOOSTM[2:0] = 2H, DI_PWR_REG = DON'T CARE)	313
19.3.1.	<i>Power Structure</i>	313
19.3.2.	<i>Reference Circuit</i>	314
19.3.3.	<i>External Component</i>	315
19.4.	POWER MODE 4 (BOOSTM[2:0] = 1H, DI_PWR_REG = 1H)	316
19.4.1.	<i>Power Structure</i>	316
19.4.2.	<i>Reference Circuit</i>	317
19.4.3.	<i>External Component</i>	318
19.5.	MAXIMUM LAYOUT RESISTANCE	319
20.	LIQUID CRYSTAL POWER SUPPLY SPECIFICATIONS	320

21. REVISION HISTORY321

List of Figures

FIGURE 1: BLOCK DIAGRAM	20
FIGURE 2: DSI SYSTEM INTERFACE DIAGRAM	39
FIGURE 3: CLOCK LANE POWER MODES.....	41
FIGURE 4: FROM ULPM TO LPM	42
FIGURE 5: FROM HIGH SPEED CLOCK MODE (HSCM) TO LPM	42
FIGURE 6: ALL THREE MODE CHANGES TO LPM	43
FIGURE 7: FROM LPM TO ULPM	43
FIGURE 8: MODE CHANGE FROM LPM TO ULPM.....	44
FIGURE 9: FROM LPM TO HSCM	44
FIGURE 10: MODE CHANGE FROM LPM TO HSCM	45
FIGURE 11: HIGH SPEED CLOCK BURST	46
FIGURE 12 GENERAL ESCAPE MODE SEQUENCE	48
FIGURE 13: LOW-POWER DATA TRANSMISSION (LPDT)	49
FIGURE 14: PAUSE (EXAMPLE)	49
FIGURE 15: ULTRA-LOW POWER STATE (ULPS)	50
FIGURE 16: REMOTE APPLICATION RESET (RAR)	51
FIGURE 17: ACKNOWLEDGE (ACK)	52
FIGURE 18: ENTERING HIGH-SPEED DATA TRANSMISSION (TSOT OF HSDT)	53
FIGURE 19: LEAVING HIGH-SPEED DATA TRANSMISSION (TEOT OF HSDT)	54
FIGURE 20: SINGLE PACKET IN HIGH-SPEED DATA TRANSMISSIONS	55
FIGURE 21: MULTIPLE PACKETS IN HIGH-SPEED DATA TRANSMISSION – EXAMPLES.....	55
FIGURE 22: NUMBER OF BYTES, N, TRANSMITTED IS AN INTEGER MULTIPLE OF THE NUMBER OF LANES.....	55
FIGURE 23: NUMBER OF BYTES, N, TRANSMITTED IS NOT AN INTEGER MULTIPLE OF THE NUMBER OF LANES (EXAMPLE 1)	56
FIGURE 24: NUMBER OF BYTES, N, TRANSMITTED IS NOT AN INTEGER MULTIPLE OF THE NUMBER OF LANES (EXAMPLE 2)	56
FIGURE 25: NUMBER OF BYTES, N, TRANSMITTED IS NOT AN INTEGER MULTIPLE OF THE NUMBER OF LANES (EXAMPLE 3)	56
FIGURE 26: CONTINUOUS MULTIPLE PACKETS IN HSDT WHEN NUMBER OF BYTES IS EQUAL ON DATA LANES AT THE END OF THE PACKET	57
FIGURE 27: CONTINUOUS MULTIPLE PACKETS IN HSDT WHEN NUMBER OF BYTES IS NOT EQUAL ON DATA LANES AT THE END OF THE PACKET (EXAMPLE 1)	57
FIGURE 28: CONTINUOUS MULTIPLE PACKETS IN HSDT WHEN NUMBER OF BYTES IS NOT EQUAL ON DATA LANES AT THE END OF THE PACKET (EXAMPLE 2)	57
FIGURE 29: CONTINUOUS MULTIPLE PACKETS IN HSDT WHEN NUMBER OF BYTES IS NOT EQUAL ON DATA LANES AT THE END OF THE PACKET (EXAMPLE 3)	58
FIGURE 30: BUS TURNAROUND PROCEDURE	59
FIGURE 31: SHORT PACKET (SPA) STRUCTURE.....	60
FIGURE 32: LONG PACKET (LPA) STRUCTURE	60
FIGURE 33: BIT ORDER OF THE BYTE ON PACKETS	61
FIGURE 34: BYTE ORDER OF THE MULTIPLE BYTE INFORMATION ON PACKETS.....	61
FIGURE 35: PACKET HEADER (PH) IN A SHORT PACKET (SPA)	62

FIGURE 36: PACKET HEADER (PH) IN A LONG PACKET (LPA).....	62
FIGURE 37: DATA IDENTIFICATION (DI) STRUCTURE.....	63
FIGURE 38: DATA IDENTIFICATION (DI) ON THE PACKET HEADER (PH).....	63
FIGURE 39: VIRTUAL CHANNEL (VC) ON THE PACKET HEADER (PH).....	63
FIGURE 40: VIRTUAL CHANNEL (VC) CONFIGURATION.....	64
FIGURE 41: DATA TYPE (DT) ON THE PACKET HEADER (PH).....	64
FIGURE 42: PACKET DATA (PD) FOR SHORT PACKET (SPA), 2 BYTES INFORMATION.....	66
FIGURE 43: PACKET DATA (PD) FOR SHORT PACKET (SPA), 1 BYTE INFORMATION.....	67
FIGURE 44: WORD COUNT (WC) IN A LONG PACKET (LPA).....	68
FIGURE 45: PACKET DATA IN SHORT AND LONG PACKETS.....	68
FIGURE 46: D [23...0] AND P [7...0] IN A SHORT PACKET (SPA).....	69
FIGURE 47: D [23...0] AND P [7...0] IN A LONG PACKET (LPA).....	69
FIGURE 48: XOR FUNCTION ON A SHORT PACKET (SPA).....	70
FIGURE 49: XOR FUNCTION ON A LONG PACKET (LPA).....	71
FIGURE 50: INTERNAL ERROR CORRECTION CODE (IECC) ON THE DISPLAY MODULE (= THE RECEIVER).....	71
FIGURE 51: INTERNAL XOR CALCULATION BETWEEN ECC AND IECC VALUES – NO ERROR.....	72
FIGURE 52: INTERNAL XOR CALCULATION BETWEEN ECC AND IECC VALUES - ERROR.....	72
FIGURE 53: 16-BIT CYCLIC REDUNDANCY CHECK (CRC) CALCULATION.....	73
FIGURE 54: CRC CALCULATION – PACKET DATA (PD) IS 01H.....	73
FIGURE 55: PACKET FOOTER (PF) EXAMPLE.....	74
FIGURE 56: DISPLAY COMMAND SET (DCS) IN SHORT PACKET (SPA) AND LONG PACKET (LPA).....	75
FIGURE 57: DISPLAY COMMAND SET (DCS) WRITE, NO PARAMETER (DCSWN-S) - EXAMPLE.....	76
FIGURE 58: DISPLAY COMMAND SET (DCS) WRITE, 1 PARAMETER (DCSW1-S) – EXAMPLE.....	77
FIGURE 59: DISPLAY COMMAND SET (DCS) WRITE LONG (DCSW-L) WITH DCS ONLY - EXAMPLE.....	79
FIGURE 60: DISPLAY COMMAND SET (DCS) WRITE LONG WITH DCS AND 1 PARAMETER - EXAMPLE.....	80
FIGURE 61: DISPLAY COMMAND SET (DCS) WRITE LONG WITH DCS AND 4 PARAMETERS - EXAMPLE.....	81
FIGURE 62: SET MAXIMUM RETURN PACKET SIZE (SMRPS-S) - EXAMPLE.....	83
FIGURE 63: DISPLAY COMMAND SET (DCS) READ, NO PARAMETER (DCSRN-S) - EXAMPLE.....	83
FIGURE 64: NULL PACKET, NO DATA (NP-L) - EXAMPLE.....	86
FIGURE 65: END OF TRANSMISSION PACKET (EOTP).....	88
FIGURE 66: END OF TRANSMISSION PACKET (EOTP)-EXAMPLES.....	88
FIGURE 67: RETURN BYTES IN SINGLE PACKET.....	89
FIGURE 68: RETURN BYTES IN SEVERAL PACKETS – NOT ALLOWED.....	89
FIGURE 69: EXCEPTION WHEN RETURNED BYTES IN SEVERAL PACKETS.....	89
FIGURE 70: ACKNOWLEDGE WITH ERROR REPORT (AWER) – EXAMPLE.....	91
FIGURE 71: ERRORS PACKETS.....	91
FIGURE 72: FLOW CHART FOR ERRORS ON DSI.....	92
FIGURE 73: DCS READ LONG RESPONSE (DCSRR-L) - EXAMPLE.....	93
FIGURE 74: DCS READ SHORT RESPONSE, 1 BYTE RETURNED (DCSRR1-S) - EXAMPLE.....	94

FIGURE 75: DCS READ SHORT RESPONSE, 2 BYTES RETURNED (DCSRR2-S) - EXAMPLE.....	95
FIGURE 76: ONE PIXEL BIT AND WRITE COLOR ORDERS	104
FIGURE 77: ONE PIXEL WRITE (DCSW-L) – EXAMPLE 1	104
FIGURE 78: RED / GREEN [0:2] SUBPIXEL WRITE (DCSW1-S) – EXAMPLE 2.....	105
FIGURE 79: GREEN [3:5] / BLUE SUBPIXEL WRITE (DCSW1-S) – EXAMPLE 3	105
FIGURE 80: ONE PIXEL BIT AND COLOR WRITE ORDERS	106
FIGURE 81: ONE PIXEL WRITE (DCSW-L) – EXAMPLE.....	106
FIGURE 82: BLUE SUBPIXEL WRITE (DCSW1-S) – EXAMPLE 2.....	107
FIGURE 83: GREEN SUBPIXEL WRITE (DCSW1-S) – EXAMPLE 3.....	107
FIGURE 84: RED SUBPIXEL WRITE (DCSW1-S) – EXAMPLE 4	107
FIGURE 85: 16-BIT PER PIXEL, DATA TYPE 00 1110 (0EH).....	108
FIGURE 86: 18-BIT PER PIXEL, DATA TYPE = 01 1110 (1EH)	109
FIGURE 87: 18-BIT PER PIXEL, DATA TYPE = 10 1110 (2EH)	110
FIGURE 88: 24-BIT PER PIXEL, DATA TYPE = 11 1110 (3EH)	111
FIGURE 89: EPF[1:0] = 10, 16-BIT DATA MAPPING TO 24-BIT	113
FIGURE 90: EPF[1:0] = 10, 18-BIT DATA MAPPING TO 24-BIT	113
FIGURE 91: COMMAND FLOW	114
FIGURE 92: ENTER IDLE MODE FLOW	272
FIGURE 93: EXIT IDLE MODE FLOW	272
FIGURE 94: ENTER/EXIT IDLE MODE SEQUENCE	273
FIGURE 95: CABC BLOCK DIAGRAM.....	275
FIGURE 96: PWM OUT ON/OFF PERIOD.....	275
FIGURE 97: SATURATION ENHANCEMENT : HSL MODEL	276
FIGURE 98: SATURATION ENHANCEMENT IMAGE (A) ORIGINAL, (B) LOW LEVEL, (C) MEDIUM LEVEL, (D) HIGH LEVEL.	276
FIGURE 99: CONTRAST ENHANCEMENT IMAGE (A) ORIGINAL, (B) AFTER ENHANCEMENT	277
FIGURE 100: SHARPNESS ENHANCEMENT IMAGE (A) ORIGINAL, (B) AFTER ENHANCEMENT.....	278
FIGURE 101: SUNLIGHT READABILITY CONCEPT (A) BACKLIGHT EFFICIENCY IS CONSUMED BY AMBIENT LIGHT, (B) ENHANCE THE IMAGE CONTENT TO AVOID THE INFLUENCE.	279
FIGURE 102: REGISTER LOADING DETECTION	280
FIGURE 103: FUNCTIONALITY DETECTION	281
FIGURE 104: POWER ON/OFF SEQUENCE WITH POWER MODE 2A	282
FIGURE 105: POWER ON/OFF SEQUENCE WITH POWER MODE 3	283
FIGURE 106: POWER ON/OFF SEQUENCE WITH POWER MODE 4	284
FIGURE 1075: POWER MODE FLOW CHART	286
FIGURE 108: EXTERNAL MTP_PWR PROGRAMMING FLOW	288
FIGURE 109: INTERNAL VGH PROGRAMMING FLOW.....	289
FIGURE 110: GAMMA ARCHITECTURE.....	290
FIGURE 111: TOUCH SYNCHRONIZATION SIGNAL	291
FIGURE 112: SPIKE/GLITCH REJECTION	295

FIGURE 113: DIFFERENTIAL INPUTS LOGICAL 0 AND 1, THRESHOLD HIGH/LOW, DIFFERENTIAL VOLTAGE RANGE297

FIGURE 114: COMMON MODE VOLTAGE ON CLOCK AND DATA CHANNELS297

FIGURE 115: DIFFERENTIAL PAIR TERMINATION RESISTOR ON THE RECEIVER SIDE298

FIGURE 116: DSI CLOCK CHANNEL TIMING.....299

FIGURE 117: DSI DATA TO CLOCK CHANNEL TIMINGS300

FIGURE 118: RISING AND FALLING TIMINGS ON CLOCK AND DATA CHANNELS301

FIGURE 119: BTA FROM THE MCU TO THE DISPLAY MODULE302

FIGURE 120: BTA FROM THE DISPLAY MODULE TO THE MCU302

FIGURE 121: DATA LANES - LOW POWER MODE TO HIGH SPEED MODE TIMINGS303

FIGURE 122: DATA LANES - HIGH SPEED MODE TO LOW POWER MODE TIMINGS304

FIGURE 123: CLOCK LANES - HIGH SPEED MODE TO/FROM LOW POWER MODE TIMINGS.....305

FIGURE 124: RESET TIMING.....308

FIGURE 125: POSITIVE NOISE PULSE DURING RESET LOW308

FIGURE 126: POWER STRUCTURE OF POWER MODE 2A310

FIGURE 127: REFERENCE CIRCUIT OF POWER MODE 2A311

FIGURE 128: POWER STRUCTURE OF POWER MODE 3.....313

FIGURE 129: REFERENCE CIRCUIT OF POWER MODE 3.....314

FIGURE 130: POWER STRUCTURE OF POWER MODE 4.....316

FIGURE 131: REFERENCE CIRCUIT OF POWER MODE 4.....317

List of Tables

TABLE 1: PIN DEFINITION	22
TABLE 2: DSI INTERFACE LANE MODE SELECTION.....	38
TABLE 3: HIGH SPEED AND LOW-POWER LANE PAIR STATE CODES	40
TABLE 4: ENTERING AND LEAVING SEQUENCES	47
TABLE 5: ESCAPE COMMANDS	48
TABLE 6: ABBREVIATIONS	55
TABLE 7: DATA TYPE (DT) FROM THE MCU TO THE DISPLAY MODULE	65
TABLE 8: DATA TYPE (DT) FROM THE DISPLAY MODULE TO THE MCU	66
TABLE 9: ONE BIT ERROR VALUE OF THE ERROR CORRECTION CODE (ECC).....	72
TABLE 10: DISPLAY COMMAND SET (DCS) WRITE, NO PARAMETERS (DCSWN-S).....	76
TABLE 11: DISPLAY COMMAND SET (DCS) WRITE, 1 PARAMETER (DCSW1-S)	77
TABLE 12: DISPLAY COMMAND SET (DCS) WRITE LONG (DCSW-L).....	78
TABLE 13: DISPLAY COMMAND SET (DCS) READ, NO PARAMETER (DCSRN-S)	82
TABLE 14: RECEIVING AND TRANSMITTING EOTP DURING LPDT.....	87
TABLE 15: ERROR REPORT (AWER) BIT DEFINITIONS.....	90
TABLE 16: INTERFACE LEVEL COMMUNICATION	96
TABLE 17: PACKET LEVEL COMMUNICATION FOR MCU-SOURCED PACKETS	96
TABLE 18: PACKET LEVEL COMMUNICATION FOR PERIPHERAL-SOURCED PACKETS.....	97
TABLE 19: DCS WRITE, 1 PARAMETER SEQUENCE – EXAMPLE 1.....	98
TABLE 20: DCS WRITE, 1 PARAMETER SEQUENCE – EXAMPLE 2.....	98
TABLE 21: DCS WRITE, 1 PARAMETER SEQUENCE – EXAMPLE 3.....	98
TABLE 22: DCS WRITE, NO PARAMETER SEQUENCE – EXAMPLE 1.....	99
TABLE 23: DCS WRITE, NO PARAMETER SEQUENCE – EXAMPLE 2.....	99
TABLE 24: DCS WRITE, NO PARAMETER SEQUENCE – EXAMPLE 3.....	99
TABLE 25: DCS WRITE LONG SEQUENCE – EXAMPLE 1	100
TABLE 26: DCS WRITE LONG SEQUENCE – EXAMPLE 2	100
TABLE 27: DCS WRITE LONG SEQUENCE – EXAMPLE 3	100
TABLE 28: DCS READ, NO PARAMETER SEQUENCE – EXAMPLE 1.....	101
TABLE 29: DCS READ, NO PARAMETER SEQUENCE – EXAMPLE 2.....	102
TABLE 30: NULL PACKET, NO DATA SEQUENCE - EXAMPLE	103
TABLE 31: END OF TRANSMISSION PACKET – EXAMPLE	103
TABLE 32: 16/18-BIT COLOR DATA MAPPING TO 24-BIT PIXEL DATA OPERATION.....	112
TABLE 33: BIST MODE PATTERN	274
TABLE 34: CHARACTERISTICS OF OUTPUT OR BI-DIRECTIONAL (I/O) PINS	287
TABLE 35: INPUT PINS	287
TABLE 36: ABSOLUTE MAXIMUM RATINGS	292
TABLE 37: SPIKE/GLITCH REJECTION.....	295
TABLE 38: DSI CLOCK CHANNEL TIMING	299

The information contained herein is the exclusive property of ILI Technology Corp. and shall not be distributed, reproduced, or disclosed in whole or in part without prior written permission of ILI Technology Corp.

TABLE 39: LIMITED CLOCK CHANNEL SPEED	299
TABLE 40: DSI DATA TO CLOCK CHANNEL TIMINGS	300
TABLE 41: RISE AND FALL TIMINGS ON CLOCK AND DATA CHANNELS	301
TABLE 42: LOW POWER STATE PERIOD TIMINGS – A	302
TABLE 43: LOW POWER STATE PERIOD TIMINGS – B	302
TABLE 44: DATA LANES - LOW POWER MODE TO HIGH SPEED MODE TIMINGS	303
TABLE 45: DATA LANES - HIGH SPEED MODE TO LOW POWER MODE TIMINGS	304
TABLE 46: CLOCK LANES - HIGH SPEED MODE TO/FROM LOW POWER MODE TIMINGS	305
TABLE 47: RESET TIMING	308
TABLE 48: RESET DESCRIPT	308
TABLE 49: DIFFERENT INPUT POWER TYPE.....	309
TABLE 50: EXTERNAL COMPONENT TABLE OF POWER MODE 2A.....	312
TABLE 51: EXTERNAL COMPONENT TABLE OF POWER MODE 3	315
TABLE 52: EXTERNAL COMPONENT TABLE OF POWER MODE 4	318
TABLE 53: MAXIMUM LAYOUT RESISTANCE	319
TABLE 54: LIQUID CRYSTAL POWER SUPPLY SPECIFICATIONS	320

1. Introduction

The ILI9881C-0D is a 16.7M single-chip (SOC) driver. It is comprised of a 2404-channel source driver (S1~S2400 and SDUM[3:0]), a gate-IC-less level shifter and a power supply circuit to drive a dot-matrix TFT LCD with 800 (RGB) x 1280 dots at maximum.

The ILI9881C-0D can configure functions via the MIPI¹ DSI² Interface; transmit video data via MIPI DSI Interface. The ILI9881C-0D supports three kinds of data types, i.e., 16-bit, 18-bit and 24-bit, for video image display in MIPI DSI interfaces. In the MIPI DSI high-speed mode, the ILI9881C-0D also provides three user-selectable hardware structures:

- ❖ Two data lane supports up to 850Mbps on the MIPI DSI link
- ❖ Three data lanes support up to 700Mbps on the MIPI DSI link
- ❖ Four data lanes support up to 550Mbps on the MIPI DSI link

The ILI9881C-0D can operate with 1.65V I/O interface voltage and supports a wide range of analog power supplies. The ILI9881C-0D supports 2 colors (Idle Mode: 2-color low power mode) display and sleep mode power management functions, ideal for portable products where battery power conservation is desirable, such as digital cellular phones, smart phones, MP3 players, personal media players and similar devices with color graphics displays.

¹ MIPI: Mobile Industry Processor Interface

² DSI: Display Serial Interface

2. Features

- ◆ Display resolution options:
 - 800 (RGB) (H) x (480 + (4 x NL)) (V)
 - 768 (RGB) (H) x (480 + (4 x NL)) (V)
 - 720 (RGB) (H) x (480 + (4 x NL)) (V)

- ◆ Display color modes
 - Full color mode:
 - 16.7M colors (24-bit data, R: 8-bit, G: 8-bit, B: 8-bit)
 - Reduced color modes:
 - 262K colors (18-bit data, R: 6-bit, G: 6-bit, B: 6-bit)
 - 65K colors (16-bit data, R: 5-bit, G: 6-bit, B: 5-bit)
 - 2 colors (Idle Mode: 2-color low power mode)

- ◆ Display module:
 - Supports 2404 source channel outputs (S1~S2400 and SDUM[3:0])
 - Supports gate control signals to gate driver in the panel
 - Supports 1-dot , 2-dot , 4-dot , N/4-dot , N/8-dot , N/16-dot , N/32-dot , column , Zig-Zag inversion
 - Gamma correction (1 preset Gamma curve)
 - On module VCOM control
 - 800x1280-dot display RAM with data compression for 2-color low power mode

- ◆ Display interface types:
 - DSI interface (DSI version 1.01 and D-PHY version 1.00):
 - 2 data lane / maximum speed 850Mbps
 - 3 data lanes / maximum speed 700Mbps
 - 4 data lanes / maximum speed 550Mbps

- ◆ Power saving modes:
 - Sleep mode

- ◆ Other on-chip functions/Miscellaneous
 - Software programmable color depth mode
 - Oscillator for display clock generation
 - DC VCOM voltage generator and adjustment
 - CABC (Content Adaptive Brightness Control) function
 - DGC (Digital Gamma Correction) function
 - IIE (Impressive Image Enhancement) function
 - VGH/VGL voltage generator for gate control signal in panel
 - Gate control signals to gate driver in panel (GIP)
 - OTP (One-Time Programming) memory store initialization register settings
 - Provide 3 times to store DC VCOM value setting and ID1 ~ ID3
 - BIST (Built-In Self-Test Pattern) mode function

- ◆ Input power:
 - VCI = 2.5V ~ 6.6V
 - VDDI = 1.65V ~ 3.6V
 - VCC1 = 1.65V ~ 6.6V
 - VCC2 = 1.65V ~ 6.6V
 - VDDAM = 1.65V ~ 3.6V
 - VSP = 4.5V ~ 6.6V
 - VSN = -6.6V ~ -4.5V
 - OTP programming voltage (MTP_PWR): 8.5V

- ◆ Source/VCOM/Gate power supply voltage:
 - VCL-GND = -3.0V ~ -2.3V
 - DC VCOM = -4.0V ~ -0.2V (12mV/step); 0V
 - VREG1OUT = 3.5V ~ 5.6V (Positive source output voltage level)
 - VREG2OUT = -5.6V ~ -3.5V (Negative source output voltage level)
 - VGH-GND = 8V ~ 18V (Positive gate driver output voltage level)
 - VGL-GND = -7V ~ -18V (Negative gate driver output voltage level)

3. Device Overview

3.1. Block Diagram

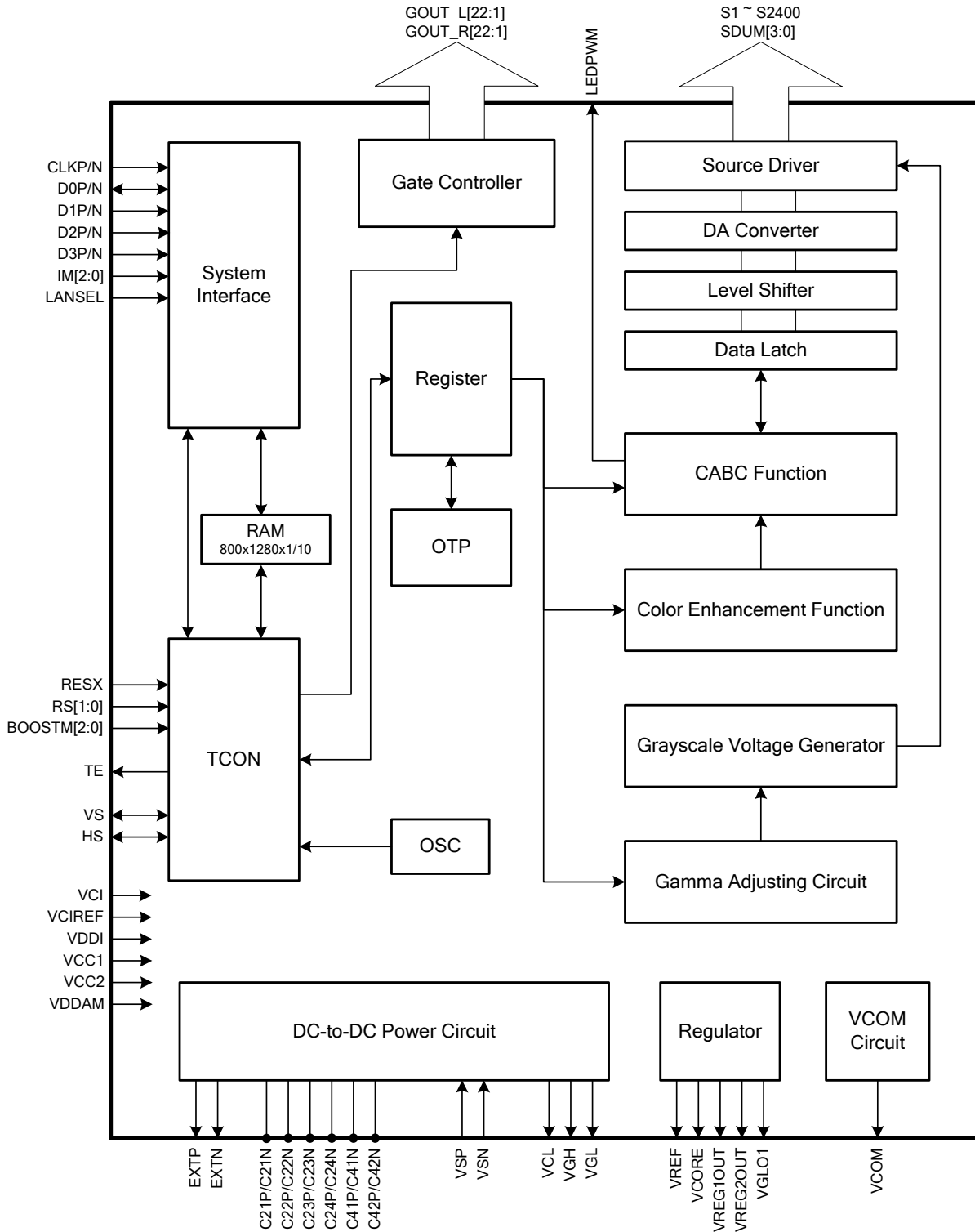

Figure 1: Block Diagram

3.2. Block Function Description

3.2.1. System Interface

The ILI9881C-0D supports DSI interfaces. The interface mode and the lane number of DSI interface can be selected by hardware pins IM[2:0], LANSEL and control register MIPI_LANE_SEL (Page4_R00h).

3.2.2. Grayscale Voltage Generating Circuit

The grayscale voltage generating circuit generates a liquid crystal drive voltage that corresponds to the grayscale level set in the Gamma correction register. The ILI9881C-0D can display 16.7M colors at maximum.

3.2.3. TCON

The TCON generates timing signals for internal circuits. Timing for display operations are outputted separately so that they do not interfere with each other.

3.2.4. OSC

The ILI9881C-0D incorporates with an RC oscillator circuit. Command settings are used to change the frame frequency.

3.2.5. RAM

The LCD driver incorporates the RAM (800x1280)/10 bits = 12800 bytes, which can store pattern data of a 800(RGB) x 1280 resolution with data compression in the Idle Mode.

3.2.6. Source Driver Circuit

The LCD display driver circuit consists of a 2404-output source driver (S1~S2400 and SDUM[3:0]). The display pattern data is latched when 800RGB pixels of data are input. The voltage is output from the source driver according to the latched data.

3.2.7. Gate Controller Circuit

The panel control circuit outputs GOUT_L/R[22:1] signals at either the VGH or VGL level.

3.2.8. DC-to-DC Power Supply Circuit

The LCD drive power supply circuit generates the voltage levels for driving a panel. Voltage levels are adjusted according to the register setting.

3.2.9. CABC (Content Adaptive Brightness Control)

The CABC (Content Adaptive Brightness Control) dynamic backlight control function is used to reduce the power consumption of the luminance source.

3.3. Pin Descriptions

Table 1: Pin Definition

Pin Name	I/O	Type	Descriptions																																																																																
Global Control Pins																																																																																			
IM[2:0]	I	VDDI	<p>- Interface mode select pins. Notes: (1) IM[2:0] pins are used to configure lane sequence and polarity (2) The bottom table is an example for MIPI 4 lane setting</p> <table border="1"> <thead> <tr> <th colspan="3">External Pad Set</th> <th colspan="5">Configuration of MIPI Lane</th> </tr> <tr> <th>IM2</th> <th>IM1</th> <th>IM0</th> <th>D0P/N Pin</th> <th>D1P/N Pin</th> <th>CLKP/N Pin</th> <th>D2P/N Pin</th> <th>D3P/N Pin</th> </tr> </thead> <tbody> <tr> <td>0</td> <td>0</td> <td>0</td> <td>D3P/N</td> <td>D2P/N</td> <td>CLKP/N</td> <td>D1P/N</td> <td>D0P/N</td> </tr> <tr> <td>0</td> <td>0</td> <td>1</td> <td>D3N/P</td> <td>D2N/P</td> <td>CLKN/P</td> <td>D1N/P</td> <td>D0N/P</td> </tr> <tr> <td>0</td> <td>1</td> <td>0</td> <td>D0P/N</td> <td>D1P/N</td> <td>CLKP/N</td> <td>D2P/N</td> <td>D3P/N</td> </tr> <tr> <td>0</td> <td>1</td> <td>1</td> <td>D0N/P</td> <td>D1N/P</td> <td>CLKN/P</td> <td>D2N/P</td> <td>D3N/P</td> </tr> <tr> <td>1</td> <td>0</td> <td>0</td> <td>D3P/N</td> <td>D0P/N</td> <td>CLKP/N</td> <td>D1P/N</td> <td>D2P/N</td> </tr> <tr> <td>1</td> <td>0</td> <td>1</td> <td>D3N/P</td> <td>D0N/P</td> <td>CLKN/P</td> <td>D1N/P</td> <td>D2N/P</td> </tr> <tr> <td>1</td> <td>1</td> <td>0</td> <td>D2P/N</td> <td>D1P/N</td> <td>CLKP/N</td> <td>D0P/N</td> <td>D3P/N</td> </tr> <tr> <td>1</td> <td>1</td> <td>1</td> <td>D2N/P</td> <td>D1N/P</td> <td>CLKN/P</td> <td>D0N/P</td> <td>D3N/P</td> </tr> </tbody> </table>	External Pad Set			Configuration of MIPI Lane					IM2	IM1	IM0	D0P/N Pin	D1P/N Pin	CLKP/N Pin	D2P/N Pin	D3P/N Pin	0	0	0	D3P/N	D2P/N	CLKP/N	D1P/N	D0P/N	0	0	1	D3N/P	D2N/P	CLKN/P	D1N/P	D0N/P	0	1	0	D0P/N	D1P/N	CLKP/N	D2P/N	D3P/N	0	1	1	D0N/P	D1N/P	CLKN/P	D2N/P	D3N/P	1	0	0	D3P/N	D0P/N	CLKP/N	D1P/N	D2P/N	1	0	1	D3N/P	D0N/P	CLKN/P	D1N/P	D2N/P	1	1	0	D2P/N	D1P/N	CLKP/N	D0P/N	D3P/N	1	1	1	D2N/P	D1N/P	CLKN/P	D0N/P	D3N/P
External Pad Set			Configuration of MIPI Lane																																																																																
IM2	IM1	IM0	D0P/N Pin	D1P/N Pin	CLKP/N Pin	D2P/N Pin	D3P/N Pin																																																																												
0	0	0	D3P/N	D2P/N	CLKP/N	D1P/N	D0P/N																																																																												
0	0	1	D3N/P	D2N/P	CLKN/P	D1N/P	D0N/P																																																																												
0	1	0	D0P/N	D1P/N	CLKP/N	D2P/N	D3P/N																																																																												
0	1	1	D0N/P	D1N/P	CLKN/P	D2N/P	D3N/P																																																																												
1	0	0	D3P/N	D0P/N	CLKP/N	D1P/N	D2P/N																																																																												
1	0	1	D3N/P	D0N/P	CLKN/P	D1N/P	D2N/P																																																																												
1	1	0	D2P/N	D1P/N	CLKP/N	D0P/N	D3P/N																																																																												
1	1	1	D2N/P	D1N/P	CLKN/P	D0N/P	D3N/P																																																																												
RS[1:0]	I	VDDI	<p>- Resolution selection pins.</p> <table border="1"> <thead> <tr> <th>RS1</th> <th>RS0</th> <th>Resolution</th> </tr> </thead> <tbody> <tr> <td>0</td> <td>0</td> <td>800 (RGB) x (480 + (4 x NL)) gate line</td> </tr> <tr> <td>0</td> <td>1</td> <td>768 (RGB) x (480 + (4 x NL)) gate line</td> </tr> <tr> <td>1</td> <td>0</td> <td>720 (RGB) x (480 + (4 x NL)) gate line</td> </tr> <tr> <td>1</td> <td>1</td> <td>Reserved</td> </tr> </tbody> </table>	RS1	RS0	Resolution	0	0	800 (RGB) x (480 + (4 x NL)) gate line	0	1	768 (RGB) x (480 + (4 x NL)) gate line	1	0	720 (RGB) x (480 + (4 x NL)) gate line	1	1	Reserved																																																																	
RS1	RS0	Resolution																																																																																	
0	0	800 (RGB) x (480 + (4 x NL)) gate line																																																																																	
0	1	768 (RGB) x (480 + (4 x NL)) gate line																																																																																	
1	0	720 (RGB) x (480 + (4 x NL)) gate line																																																																																	
1	1	Reserved																																																																																	
LANSEL	I	VDDI	<p>- MIPI DSI Lane number selection pin LANSEL="1", MIPI DSI is 2 Lane mode LANSEL="0", MIPI DSI is 3 or 4 Lane mode <i>Note: Please reference "Table 2 DSI Interface Lane Mode Selection"</i></p>																																																																																
BOOSTM[2:0]	I	VDDI	<p>- Power type selection pins</p> <table border="1"> <thead> <tr> <th>Page4_R6Eh DI_PWR_REG</th> <th>BOOSTM2</th> <th>BOOSTM1</th> <th>BOOSTM0</th> <th>NOTE</th> </tr> </thead> <tbody> <tr> <td>0</td> <td>0</td> <td>0</td> <td>1</td> <td>Power Mode 2A External VDDI, VSP and VSN (VCI=VSP) <i>Note 1</i></td> </tr> <tr> <td>1</td> <td>0</td> <td>0</td> <td>1</td> <td>Power Mode 4 External VDDI, VCI, VSP and VSN</td> </tr> <tr> <td>X</td> <td>0</td> <td>1</td> <td>0</td> <td>Power Mode 3 External VDDI and VCI (with ILI4003)</td> </tr> <tr> <td colspan="4" style="text-align: center;">prohibited</td> <td>-</td> </tr> </tbody> </table> <p>The default value of DI_PWR_REG is "1". <i>Note 1: VCI and VSP pads must be connected by external metal path.</i></p>	Page4_R6Eh DI_PWR_REG	BOOSTM2	BOOSTM1	BOOSTM0	NOTE	0	0	0	1	Power Mode 2A External VDDI, VSP and VSN (VCI=VSP) <i>Note 1</i>	1	0	0	1	Power Mode 4 External VDDI, VCI, VSP and VSN	X	0	1	0	Power Mode 3 External VDDI and VCI (with ILI4003)	prohibited				-																																																							
Page4_R6Eh DI_PWR_REG	BOOSTM2	BOOSTM1	BOOSTM0	NOTE																																																																															
0	0	0	1	Power Mode 2A External VDDI, VSP and VSN (VCI=VSP) <i>Note 1</i>																																																																															
1	0	0	1	Power Mode 4 External VDDI, VCI, VSP and VSN																																																																															
X	0	1	0	Power Mode 3 External VDDI and VCI (with ILI4003)																																																																															
prohibited				-																																																																															
RESX	I	VDDI	<p>- The external reset input Initializes the chip with a low input. Be sure to execute a power-on reset after supplying power. Fix to VDDI level when not in use.</p>																																																																																
TE	O	VDDI	<p>- Tearing effect output pin. Leave the pin open when not in use.</p>																																																																																
VS	I/O	VDDI	<p>- Touch synchronization signal (VSOUT). Fix to VSS level when not in use.</p>																																																																																
HS	I/O	VDDI	<p>- Touch synchronization signal (HSOUT). Fix to VSS level when not in use.</p>																																																																																
LEDPWM	O	VDDI	<p>- LCD backlight control PWM output pin. Leave the pin open when not in use.</p>																																																																																
DSI Interface Signal Pins																																																																																			
CLKP CLKN	I	LVDSVDD	<p>- MIPI DSI differential clock pair Leave it open or fix to LVDSVSS level when not in use.</p>																																																																																
D0P D0N	I/O	LVDSVDD	<p>- MIPI DSI differential data pair. (Data lane 0) Leave it open or fix to LVDSVSS level when not in use.</p>																																																																																

D1P D1N	I	LVDSVDD	- MIPI DSI differential data pair. (Data lane 1) Leave it open or fix to LVDSVSS level when not in use.										
D2P D2N	I	LVDSVDD	- MIPI DSI differential data pair. (Data lane 2) Leave it open or fix to LVDSVSS level when not in use.										
D3P D3N	I	LVDSVDD	- MIPI DSI differential data pair. (Data lane 3) Leave it open or fix to LVDSVSS level when not in use.										
Source / Panel Control / VCOM Signal Pins													
S[2400:1]	O	Analog	- Output source driver signals. The D/A converted 256-gray-scale analog voltage output. Source output mapping with different resolution <table border="1" style="margin-left: 20px;"> <thead> <tr> <th>Disaply resulation</th> <th>Source channels</th> </tr> </thead> <tbody> <tr> <td>800 (RGB)</td> <td>S1 ~ S2400</td> </tr> <tr> <td>768 (RGB)</td> <td>S1 ~ S1152, S1249 ~ S2400</td> </tr> <tr> <td>720 (RGB)</td> <td>S1 ~ S1080, S1321 ~ S2400</td> </tr> <tr> <td>800 (RGB) + Zig-Zag</td> <td>S1 ~ S2400, SDUM[2:1]</td> </tr> </tbody> </table>	Disaply resulation	Source channels	800 (RGB)	S1 ~ S2400	768 (RGB)	S1 ~ S1152, S1249 ~ S2400	720 (RGB)	S1 ~ S1080, S1321 ~ S2400	800 (RGB) + Zig-Zag	S1 ~ S2400, SDUM[2:1]
Disaply resulation	Source channels												
800 (RGB)	S1 ~ S2400												
768 (RGB)	S1 ~ S1152, S1249 ~ S2400												
720 (RGB)	S1 ~ S1080, S1321 ~ S2400												
800 (RGB) + Zig-Zag	S1 ~ S2400, SDUM[2:1]												
SDUM[3:0]	O	Analog	- Dummy Source Leave the pin open when not in use.										
GOUT_L[22:1]	O	Analog	- Gate control signals for panel in left side of IC Leave the pin open when not in use.										
GOUT_R[22:1]	O	Analog	- Gate control signals for panel in right side of IC Leave the pin open when not in use.										
VCOM	O	Analog	- Regulator output for common voltage of panel Connect to a stabilizing capacitor between VCOM and VSSA.										
Power Supply Pins													
VCI	I	Power Supply	- Power supply for analog circuits. Connect to an external power supply of 2.5V to 6.6V										
VCIREF	I	Power Supply	- Power supply for analog circuits. Connect to an external power supply of 2.5V to 6.6V										
VDDI	I	Power Supply	- Power supply for I/O pads. Connect to an external power supply of 1.65V to 3.6V										
VCC1	I	Power Supply	- Power supply for internal logic regulator. Connect to an external power supply of 1.65V to 6.6V										
VCC2	I	Power Supply	- Power supply for internal logic regulator. Connect to an external power supply of 1.65V to 6.6V										
VDDAM	I	Power Supply	- Power supply for MIPI DSI regulator. Connect to an external power supply of 1.65V to 3.6V										
VSP	I	Power Supply	- Input voltage from step-up circuit. Connect to an external power supply of 4.5V to 6.6V										
VSN	I	Power Supply	- Input voltage from step-up circuit. Connect to an external power supply of -4.5V to -6.6V.										
VSSA	I	Ground	- System ground for the analog circuit In the case of COG, connect to GND on the FPC to prevent noise.										
VSSREF	I	Ground	- System ground for the analog circuit In the case of COG, connect to GND on the FPC to prevent noise.										
LVDSVSS	I	Ground	- System ground for MIPI DSI analog ground In the case of COG, connect to GND on the FPC to prevent noise.										
VSS	I	Ground	- System ground for digital circuit In the case of COG, connect to GND on the FPC to prevent noise.										
MTP_PWR	I	Power Supply	- Input power for OTP programming. MTP_PWR=8. 5V When not under programming, let MTP_PWR float or connect to ground.										
DC-to-DC Circuit Pins													
VREG1OUT	O	Analog	- Regulator output voltage from VSP, It's for positive gray scale voltage. Connect to a stabilizing capacitor between GVDD and VSSA.										
VREG2OUT	O	Analog	- Regulator output voltage from VSN, It's for negative gray scale voltage. Connect to a stabilizing capacitor between NGVDD and VSSA.										
VCL	O	Analog	- Output voltage from step-up circuit										

			Connect to a stabilizing capacitor between VCL and VSSA.
VGH	O	Analog	- Output voltage from step-up circuit Connect to a stabilizing capacitor between VGH and VSSA.
VGL	O	Analog	- Output voltage from step-up circuit Connect to a stabilizing capacitor between VGL and VSSA.
VGLO1	O	Analog	- Negative power supply to panel GIP circuits If need different VGL voltage, must connect to a stabilizing capacitor between VGLO1 and VSSA.
EXTP	O	VCI	- Control signal output to generate VSP
EXTN	O	VCI	- Control signal output to generate VSN
LVDSVDD	O	Analog	- MIPI DSI regulator output
VREF	O	Analog	- Reference voltage from internal band gap circuit (1.8V typical)
VCORE	O	Analog	- Internal logic regulator output (1.5V typical) Connect to a stabilizing capacitor between VCORE and VSSA.
C21P / C21N C22P / C22N	I/O	Step-up Capacitor	- Connect the charge-pumping capacitor for generating VGH level.
C23P / C23N C24P / C24N	I/O	Step-up Capacitor	- Connect the charge-pumping capacitor for generating VGL level.
C41P / C41N C42P / C42N	I/O	Step-up Capacitor	- Connect the charge-pumping capacitor for generating VCL level.
Test / Dummy Pins			
PCLK	I	VDDI	- Test pins Unused pins should be left open.
D[7:0]	I/O	VDDI	- Test pins Unused pins should be left open or connected to VSS, VDDI.
TEST[5:0]	I/O	VDDI	- Test pins Unused pins should be left open or connected to VSS, VDDI.
TOUT[3:0]	I/O	VDDI	- Test pins Unused pins should be left open or connected to VSS, VDDI.
VTESTOUTP	O	Analog	- Analog test output pin Let it open.
VTESTOUTN	O	Analog	- Analog test output pin Let it open.
CSX	I	VDDI	- Test pins Fix to VDDI or VSS level when not in use.
DCX	I	VDDI	- Test pins Fix to VDDI or VSS level when not in use.
SCL	I	VDDI	- Test pins Fix to VDDI or VSS level when not in use.
SDI	I	VDDI	- Test pins Leave the pin open when not in use.
SDO	O	VDDI	- Test pins Leave the pin open when not in use.
TE1	O	VDDI	- Test pins. Leave the pin open when not in use.
C31P	-	-	- Dummy pins Let it open.
VCOMR	-	-	- Dummy pins Let it open.
VGLO2DUMMY	-	-	- Dummy pins Let it open.
DUMMYR1	-	Analog	- dummy pins Propose to connect these two pads separately when use for bonding resistance measurement
VSSDUMMY	-	-	- Dummy pins Let it open.
DUMMY[85:3]	-	-	- Dummy pins Let it open.

DUMMYN	-	-	- Dummy pins Let it open.
DUMMYP	-	-	- Dummy pins Let it open.

3.4. Pin Assignment

Chip Size: 27840 um x 875 um

Pad Location: Pad Center.

Coordinate Origin: Chip center

Bump Size:

1. 30um x 73um
Pad 1 to 608.
2. 16um x 65um
Pad 609 to 3092.

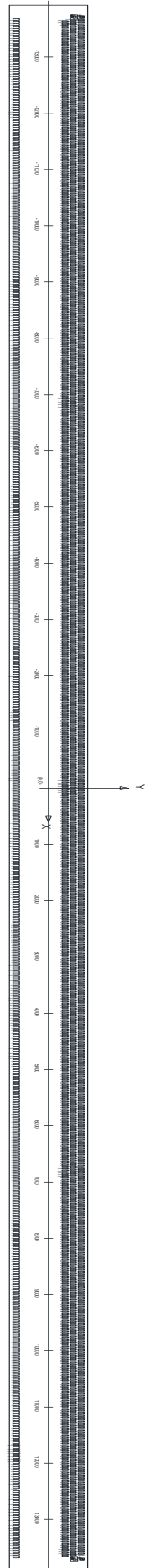
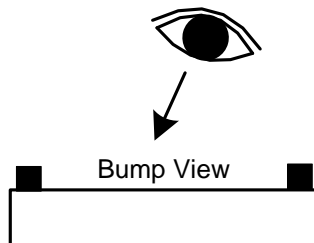

3.5. Bump Arrangement

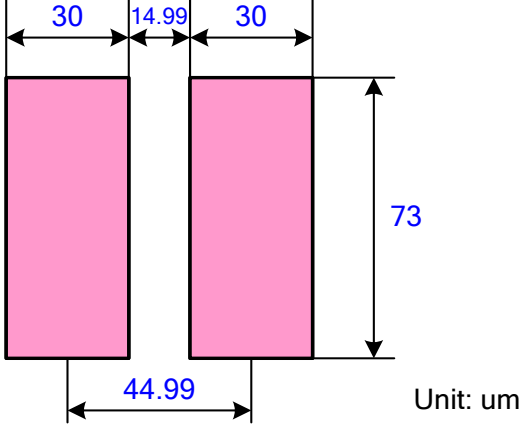
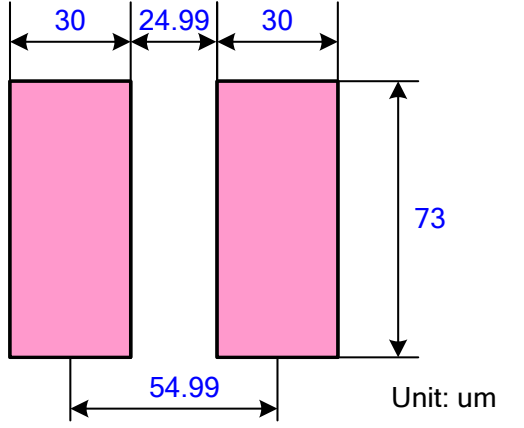
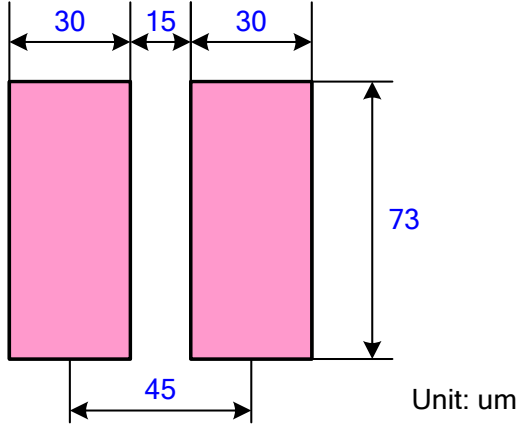
<p>Input PAD (No. 1~27, 28~304, 305~581, 582~608)</p>	 <p>Unit: um</p>
<p>Input PAD (No. 27~28, 581~582)</p>	 <p>Unit: um</p>
<p>Input PAD (No. 304~305)</p>	 <p>Unit: um</p>

Output PAD
(No. 609~3092)

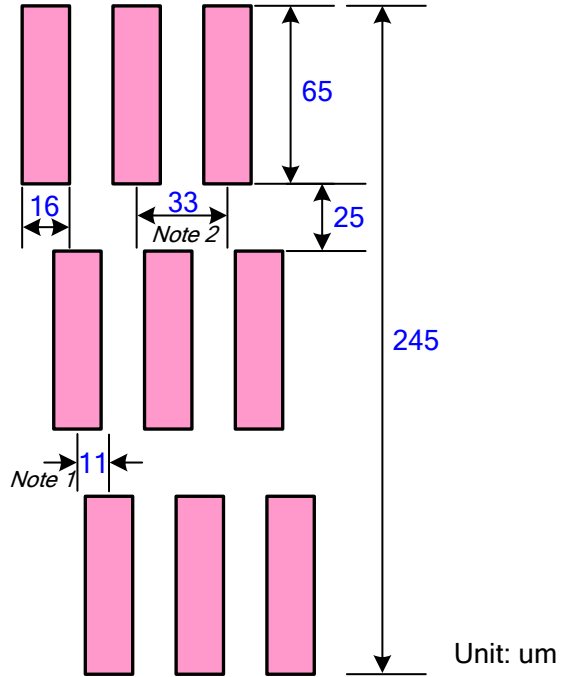

Notes:

1. Pad has temperature compensation design, so the space may be 11um or 10.99um.
2. Pad has temperature compensation design, so the space may be 33um or 32.99um.

Alignment mark R

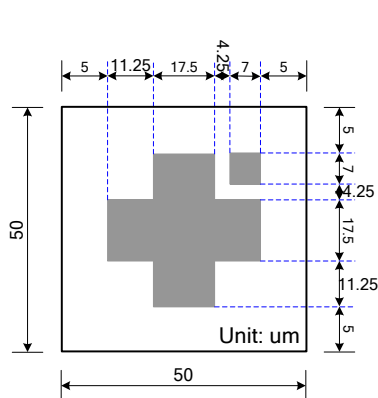

Alignment mark: (13706,372.5)

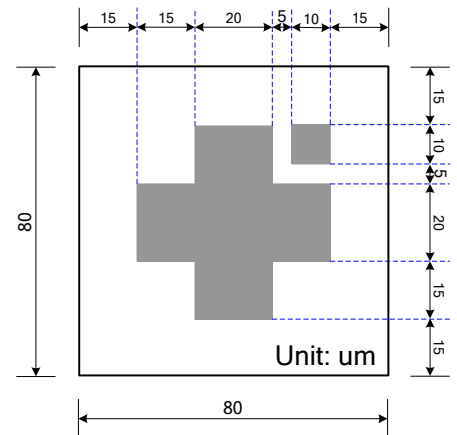

Alignment mark: (13706,285.5)

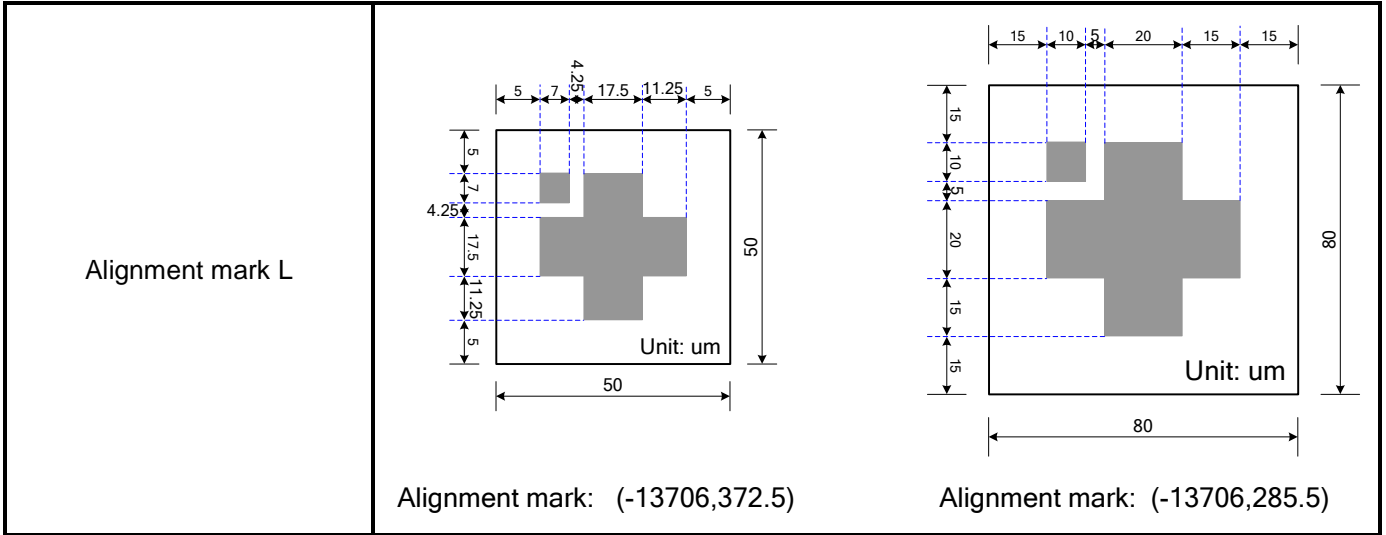

3.6. Pad Coordination

No.	Name	X	Y
1	DUMMY1	-13664.47	-361
2	DUMMY1	-13619.48	-361
3	GOUT_L1	-13574.49	-361
4	GOUT_L2	-13529.5	-361
5	GOUT_L3	-13484.51	-361
6	GOUT_L4	-13439.52	-361
7	GOUT_L5	-13394.53	-361
8	GOUT_L6	-13349.54	-361
9	GOUT_L7	-13304.55	-361
10	GOUT_L8	-13259.56	-361
11	GOUT_L9	-13214.57	-361
12	GOUT_L10	-13169.58	-361
13	GOUT_L11	-13124.59	-361
14	GOUT_L12	-13079.6	-361
15	GOUT_L13	-13034.61	-361
16	GOUT_L14	-12989.62	-361
17	GOUT_L15	-12944.63	-361
18	GOUT_L16	-12899.64	-361
19	GOUT_L17	-12854.65	-361
20	GOUT_L18	-12809.66	-361
21	GOUT_L19	-12764.67	-361
22	GOUT_L20	-12719.68	-361
23	GOUT_L21	-12674.69	-361
24	GOUT_L22	-12629.7	-361
25	VCOM	-12584.71	-361
26	VCOM	-12539.72	-361
27	VCOM	-12494.73	-361
28	VSSA	-12449.74	-361
29	VSSA	-12394.75	-361
30	VSSA	-12349.76	-361
31	VSSA	-12304.77	-361
32	VSSA	-12259.78	-361
33	VSSA	-12214.79	-361
34	VSSA	-12169.8	-361
35	VSSA	-12124.81	-361
36	VSSA	-12079.82	-361
37	VSSA	-12034.83	-361
38	VTESTOUTP	-11989.84	-361
39	VTESTOUTP	-11944.85	-361
40	LVDSVSS	-11899.86	-361
41	D0N	-11854.87	-361
42	D0N	-11809.88	-361
43	D0N	-11764.89	-361
44	D0N	-11719.9	-361
45	D0N	-11674.91	-361
46	D0P	-11629.92	-361
47	D0P	-11584.93	-361
48	D0P	-11539.94	-361
49	D0P	-11494.95	-361
50	D0P	-11449.96	-361
51	D0P	-11404.97	-361
52	D0P	-11359.98	-361
53	LVDSVSS	-11314.99	-361
54	D1N	-11270	-361
55	D1N	-11225.01	-361
56	D1N	-11180.02	-361
57	D1N	-11135.03	-361
58	D1N	-11090.04	-361
59	D1N	-11045.05	-361
60	D1P	-11000.06	-361
61	D1P	-10955.07	-361
62	D1P	-10910.08	-361
63	D1P	-10865.09	-361
64	D1P	-10820.1	-361
65	D1P	-10775.11	-361
66	LVDSVSS	-10730.12	-361
67	CLKN	-10685.13	-361
68	CLKN	-10640.14	-361
69	CLKN	-10595.15	-361
70	CLKN	-10550.16	-361
71	CLKN	-10505.17	-361
72	CLKN	-10460.18	-361
73	CLKP	-10415.19	-361
74	CLKP	-10370.2	-361
75	CLKP	-10325.21	-361
76	CLKP	-10280.22	-361
77	CLKP	-10235.23	-361
78	CLKP	-10190.24	-361
79	LVDSVSS	-10145.25	-361
80	D2N	-10100.26	-361
81	D2N	-10055.27	-361
82	D2N	-10010.28	-361
83	D2N	-9965.29	-361
84	D2N	-9920.3	-361
85	D2N	-9875.31	-361
86	D2P	-9830.32	-361
87	D2P	-9785.33	-361
88	D2P	-9740.34	-361
89	D2P	-9695.35	-361
90	D2P	-9650.36	-361
91	D2P	-9605.37	-361
92	LVDSVSS	-9560.38	-361
93	D3N	-9515.39	-361
94	D3N	-9470.4	-361
95	D3N	-9425.41	-361
96	D3N	-9380.42	-361
97	D3N	-9335.43	-361
98	D3N	-9290.44	-361
99	D3P	-9245.45	-361
100	D3P	-9200.46	-361

No.	Name	X	Y
101	D3P	-9155.47	-361
102	D3P	-9110.48	-361
103	D3P	-9065.49	-361
104	D3P	-9020.5	-361
105	LVDSVSS	-8975.51	-361
106	LVDSVSS	-8930.52	-361
107	LVDSVSS	-8885.53	-361
108	LVDSVSS	-8840.54	-361
109	LVDSVSS	-8795.55	-361
110	LVDSVSS	-8750.56	-361
111	LVDSVSS	-8705.57	-361
112	LVDSVSS	-8660.58	-361
113	LVDSVSS	-8615.59	-361
114	LVDSVSS	-8570.6	-361
115	LVDSVSS	-8525.61	-361
116	LVDSVSS	-8480.62	-361
117	LVDSVDD	-8435.63	-361
118	LVDSVDD	-8390.64	-361
119	LVDSVDD	-8345.65	-361
120	LVDSVDD	-8300.66	-361
121	LVDSVDD	-8255.67	-361
122	LVDSVDD	-8210.68	-361
123	LVDSVDD	-8165.69	-361
124	LVDSVDD	-8120.7	-361
125	LVDSVDD	-8075.71	-361
126	LVDSVDD	-8030.72	-361
127	LVDSVDD	-7985.73	-361
128	LVDSVDD	-7940.74	-361
129	VDDAM	-7895.75	-361
130	VDDAM	-7850.76	-361
131	VDDAM	-7805.77	-361
132	VDDAM	-7760.78	-361
133	VDDAM	-7715.79	-361
134	VDDAM	-7670.8	-361
135	VDDAM	-7625.81	-361
136	VDDAM	-7580.82	-361
137	VDDAM	-7535.83	-361
138	VDDAM	-7490.84	-361
139	VDDAM	-7445.85	-361
140	VDDAM	-7400.86	-361
141	VCC1	-7355.87	-361
142	VCC1	-7310.88	-361
143	VCC1	-7265.89	-361
144	VCC1	-7220.9	-361
145	VCC1	-7175.91	-361
146	VCC1	-7130.92	-361
147	VCC1	-7085.93	-361
148	VCC1	-7040.94	-361
149	VCC1	-6995.95	-361
150	VCC1	-6950.96	-361
151	VCC1	-6905.97	-361
152	VCC1	-6860.98	-361
153	VCC1	-6815.99	-361
154	VCC1	-6771	-361
155	VCC1	-6726.01	-361
156	VCORE	-6681.02	-361
157	VCORE	-6636.03	-361
158	VCORE	-6591.04	-361
159	VCORE	-6546.05	-361
160	VCORE	-6501.06	-361
161	VCORE	-6456.07	-361
162	VCORE	-6411.08	-361
163	VCORE	-6366.09	-361
164	VCORE	-6321.1	-361
165	VCORE	-6276.11	-361
166	VCORE	-6231.12	-361
167	VCORE	-6186.13	-361
168	VCORE	-6141.14	-361
169	VCORE	-6096.15	-361
170	VCORE	-6051.16	-361
171	VSS	-6006.17	-361
172	VSS	-5961.18	-361
173	VSS	-5916.19	-361
174	VSS	-5871.2	-361
175	VSS	-5826.21	-361
176	VSS	-5781.22	-361
177	VSS	-5736.23	-361
178	VSS	-5691.24	-361
179	VSS	-5646.25	-361
180	VSS	-5601.26	-361
181	VSS	-5556.27	-361
182	VSS	-5511.28	-361
183	VSS	-5466.29	-361
184	VSS	-5421.3	-361
185	VSS	-5376.31	-361
186	VSS	-5331.32	-361
187	TOUT3	-5286.33	-361
188	TOUT2	-5241.34	-361
189	TOUT2	-5196.35	-361
190	TOUT1	-5151.36	-361
191	TOUT1	-5106.37	-361
192	TOUT0	-5061.38	-361
193	TOUT0	-5016.39	-361
194	DUMMYP	-4971.4	-361
195	DUMMYP	-4926.41	-361
196	DUMMYP	-4881.42	-361
197	DUMMYP	-4836.43	-361
198	DUMMYP	-4791.44	-361
199	DUMMYP	-4746.45	-361
200	DUMMYP	-4701.46	-361

No.	Name	X	Y
201	DUMMYP	-4656.47	-361
202	DUMMYP	-4611.48	-361
203	DUMMYP	-4566.49	-361
204	DUMMYP	-4521.5	-361
205	DUMMYP	-4476.51	-361
206	DUMMYP	-4431.52	-361
207	DUMMYP	-4386.53	-361
208	DUMMYP	-4341.54	-361
209	DUMMYP	-4296.55	-361
210	DUMMYP	-4251.56	-361
211	DUMMYP	-4206.57	-361
212	DUMMYP	-4161.58	-361
213	DUMMYP	-4116.59	-361
214	DUMMYP	-4071.6	-361
215	DUMMYP	-4026.61	-361
216	DUMMYP	-3981.62	-361
217	DUMMYP	-3936.63	-361
218	DUMMYP	-3891.64	-361
219	DUMMYP	-3846.65	-361
220	DUMMYP	-3801.66	-361
221	DUMMYP	-3756.67	-361
222	DUMMYP	-3711.68	-361
223	DUMMYP	-3666.69	-361
224	DUMMYP	-3621.7	-361
225	DUMMYP	-3576.71	-361
226	DUMMYP	-3531.72	-361
227	DUMMYP	-3486.73	-361
228	DUMMYP	-3441.74	-361
229	DUMMYP	-3396.75	-361
230	DUMMYP	-3351.76	-361
231	DUMMYP	-3306.77	-361
232	DUMMYP	-3261.78	-361
233	DUMMYP	-3216.79	-361
234	DUMMYP	-3171.8	-361
235	DUMMYP	-3126.81	-361
236	DUMMYP	-3081.82	-361
237	DUMMYP	-3036.83	-361
238	DUMMYP	-2991.84	-361
239	VSS	-2946.85	-361
240	VSS	-2901.86	-361
241	D7	-2856.87	-361
242	D7	-2811.88	-361
243	D6	-2766.89	-361
244	D6	-2721.9	-361
245	D5	-2676.91	-361
246	D5	-2631.92	-361
247	D4	-2586.93	-361
248	D4	-2541.94	-361
249	D3	-2496.95	-361
250	D3	-2451.96	-361
251	D2	-2406.97	-361
252	D2	-2361.98	-361
253	D1	-2316.99	-361
254	D1	-2272	-361
255	D0	-2227.01	-361
256	D0	-2182.02	-361
257	HS	-2137.03	-361
258	HS	-2092.04	-361
259	VS	-2047.05	-361
260	VS	-2002.06	-361
261	VSSDUMMY	-1957.07	-361
262	VSSDUMMY	-1912.08	-361
263	PCLK	-1867.09	-361
264	PCLK	-1822.1	-361
265	DCX	-1777.11	-361
266	DCX	-1732.12	-361
267	CSX	-1687.13	-361
268	CSX	-1642.14	-361
269	SCL	-1597.15	-361
270	SCL	-1552.16	-361
271	SDI	-1507.17	-361
272	SDI	-1462.18	-361
273	SDO	-1417.19	-361
274	SDO	-1372.2	-361
275	LEDPWM	-1327.21	-361
276	LEDPWM	-1282.22	-361
277	LEDPWM	-1237.23	-361
278	LEDPWM	-1192.24	-361
279	TE	-1147.25	-361
280	TE	-1102.26	-361
281	TE	-1057.27	-361
282	TE	-1012.28	-361
283	TE	-967.29	-361
284	TE	-922.3	-361
285	TE1	-877.31	-361
286	TE1	-832.32	-361
287	TE1	-787.33	-361
288	TE1	-742.34	-361
289	TE1	-697.35	-361
290	TE1	-652.36	-361
291	RESX	-607.37	-361
292	RESX	-562.38	-361
293	RESX	-517.39	-361
294	RESX	-472.4	-361
295	TEST5	-427.41	-361
296	TEST4	-382.42	-361
297	TEST3	-337.43	-361
298	TEST2	-292.44	-361
299	TEST1	-247.45	-361
300</			

No.	Name	X	Y
401	VSSA	4341.54	-361
402	VSSA	4386.53	-361
403	VSSA	4431.52	-361
404	VSSA	4476.51	-361
405	VSSA	4521.5	-361
406	VSSA	4566.49	-361
407	VREGIOUT	4611.48	-361
408	VREGIOUT	4656.47	-361
409	VREGIOUT	4701.46	-361
410	VREGIOUT	4746.45	-361
411	VREGIOUT	4791.44	-361
412	VREGIOUT	4836.43	-361
413	VREF	4881.42	-361
414	VREF	4926.41	-361
415	VREF	4971.4	-361
416	VSS	5016.39	-361
417	VSS	5061.38	-361
418	VSS	5106.37	-361
419	VSS	5151.36	-361
420	VSS	5196.35	-361
421	VCI	5241.34	-361
422	VCI	5286.33	-361
423	VCI	5331.32	-361
424	VCI	5376.31	-361
425	VCI	5421.3	-361
426	VCI	5466.29	-361
427	VCI	5511.28	-361
428	VCI	5556.27	-361
429	VCI	5601.26	-361
430	VCL	5646.25	-361
431	VCL	5691.24	-361
432	VCL	5736.23	-361
433	VCL	5781.22	-361
434	C41P	5826.21	-361
435	C41P	5871.2	-361
436	C41P	5916.19	-361
437	C41P	5961.18	-361
438	C41P	6006.17	-361
439	C41P	6051.16	-361
440	C41P	6096.15	-361
441	C41N	6141.14	-361
442	C41N	6186.13	-361
443	C41N	6231.12	-361
444	C41N	6276.11	-361
445	C41N	6321.1	-361
446	C41N	6366.09	-361
447	C41N	6411.08	-361
448	C42P	6456.07	-361
449	C42P	6501.06	-361
450	C42P	6546.05	-361
451	C42P	6591.04	-361
452	C42P	6636.03	-361
453	C42P	6681.02	-361
454	C42P	6726.01	-361
455	C42N	6771	-361
456	C42N	6815.99	-361
457	C42N	6860.98	-361
458	C42N	6905.97	-361
459	C42N	6950.96	-361
460	C42N	6995.95	-361
461	C42N	7040.94	-361
462	VSP	7085.93	-361
463	VSP	7130.92	-361
464	VSP	7175.91	-361
465	VSP	7220.9	-361
466	VSP	7265.89	-361
467	VSP	7310.88	-361
468	VSP	7355.87	-361
469	VSN	7400.86	-361
470	VSN	7445.85	-361
471	VSN	7490.84	-361
472	VSN	7535.83	-361
473	VSN	7580.82	-361
474	VSN	7625.81	-361
475	VSN	7670.8	-361
476	C21N	7715.79	-361
477	C21N	7760.78	-361
478	C21N	7805.77	-361
479	C21N	7850.76	-361
480	C21N	7895.75	-361
481	C21N	7940.74	-361
482	C21N	7985.73	-361
483	C21P	8030.72	-361
484	C21P	8075.71	-361
485	C21P	8120.7	-361
486	C21P	8165.69	-361
487	C21P	8210.68	-361
488	C21P	8255.67	-361
489	C21P	8300.66	-361
490	C22N	8345.65	-361
491	C22N	8390.64	-361
492	C22N	8435.63	-361
493	C22N	8480.62	-361
494	C22N	8525.61	-361
495	C22N	8570.6	-361
496	C22N	8615.59	-361
497	C22P	8660.58	-361
498	C22P	8705.57	-361
499	C22P	8750.56	-361
500	C22P	8795.55	-361

No.	Name	X	Y
501	C22P	8840.54	-361
502	C22P	8885.53	-361
503	C22P	8930.52	-361
504	VGH	8975.51	-361
505	VGH	9020.5	-361
506	VGH	9065.49	-361
507	VGH	9110.48	-361
508	VGH	9155.47	-361
509	VGH	9200.46	-361
510	VCI	9245.45	-361
511	VCI	9290.44	-361
512	VCI	9335.43	-361
513	VCI	9380.42	-361
514	VCI	9425.41	-361
515	VCI	9470.4	-361
516	VSS	9515.39	-361
517	VSS	9560.38	-361
518	VSS	9605.37	-361
519	VSS	9650.36	-361
520	VSS	9695.35	-361
521	VSS	9740.34	-361
522	VSS	9785.33	-361
523	VSS	9830.32	-361
524	C23P	9875.31	-361
525	C23P	9920.3	-361
526	C23P	9965.29	-361
527	C23P	10010.28	-361
528	C23P	10055.27	-361
529	C23P	10100.26	-361
530	C23P	10145.25	-361
531	C23N	10190.24	-361
532	C23N	10235.23	-361
533	C23N	10280.22	-361
534	C23N	10325.21	-361
535	C23N	10370.2	-361
536	C23N	10415.19	-361
537	C23N	10460.18	-361
538	C24P	10505.17	-361
539	C24P	10550.16	-361
540	C24P	10595.15	-361
541	C24P	10640.14	-361
542	C24P	10685.13	-361
543	C24P	10730.12	-361
544	C24P	10775.11	-361
545	C24N	10820.1	-361
546	C24N	10865.09	-361
547	C24N	10910.08	-361
548	C24N	10955.07	-361
549	C24N	11000.06	-361
550	C24N	11045.05	-361
551	C24N	11090.04	-361
552	VGL	11135.03	-361
553	VGL	11180.02	-361
554	VGL	11225.01	-361
555	VGL	11270	-361
556	VGL	11314.99	-361
557	VGL	11359.98	-361
558	C31P	11404.97	-361
559	C31P	11449.96	-361
560	C31P	11494.95	-361
561	C31P	11539.94	-361
562	C31P	11584.93	-361
563	C31P	11629.92	-361
564	C31P	11674.91	-361
565	VGLO2DUMMY	11719.9	-361
566	VGLO2DUMMY	11764.89	-361
567	VGLO2DUMMY	11809.88	-361
568	VGLO2DUMMY	11854.87	-361
569	VGLO2DUMMY	11899.86	-361
570	VGLO2DUMMY	11944.85	-361
571	VGLO2DUMMY	11989.84	-361
572	VGL01	12034.83	-361
573	VGL01	12079.82	-361
574	VGL01	12124.81	-361
575	VGL01	12169.8	-361
576	VGL01	12214.79	-361
577	VGL01	12259.78	-361
578	VCOMR	12304.77	-361
579	VCOMR	12349.76	-361
580	DUMMYR1	12394.75	-361
581	DUMMYR1	12439.74	-361
582	VCOM	12494.73	-361
583	VCOM	12539.72	-361
584	VCOM	12584.71	-361
585	GOUT_R22	12629.7	-361
586	GOUT_R21	12674.69	-361
587	GOUT_R20	12719.68	-361
588	GOUT_R19	12764.67	-361
589	GOUT_R18	12809.66	-361
590	GOUT_R17	12854.65	-361
591	GOUT_R16	12899.64	-361
592	GOUT_R15	12944.63	-361
593	GOUT_R14	12989.62	-361
594	GOUT_R13	13034.61	-361
595	GOUT_R12	13079.6	-361
596	GOUT_R11	13124.59	-361
597	GOUT_R10	13169.58	-361
598	GOUT_R9	13214.57	-361
599	GOUT_R8	13259.56	-361
600	GOUT_R7	13304.55	-361

No.	Name	X	Y
601	GOUT_R6	13349.54	-361
602	GOUT_R5	13394.53	-361
603	GOUT_R4	13439.52	-361
604	GOUT_R3	13484.51	-361
605	GOUT_R2	13529.5	-361
606	GOUT_R1	13574.49	-361
607	DUMMY2	13619.48	-361
608	DUMMY2	13664.47	-361
609	DUMMY80	13653.39	185
610	DUMMY81	13642.4	275
611	DUMMY82	13631.4	365
612	DUMMY3	13620.4	185
613	DUMMY4	13609.4	275
614	DUMMY5	13598.4	365
615	DUMMY6	13587.4	185
616	DUMMY7	13576.4	275
617	DUMMY8	13565.4	365
618	DUMMY9	13554.4	185
619	SDUM3	13543.4	275
620	SDUM2	13532.4	365
621	S2400	13521.4	185
622	S2399	13510.4	275
623	S2398	13499.4	365
624	S2397	13488.4	185
625	S2396	13477.4	275
626	S2395	13466.4	365
627	S2394	13455.4	185
628	S2393	13444.4	275
629	S2392	13433.4	365
630	S2391	13422.4	185
631	S2390	13411.4	275
632	S2389	13400.4	365
633	S2388	13389.4	185
634	S2387	13378.4	275
635	S2386	13367.4	365
636	S2385	13356.4	185
637	S2384	13345.4	275
638	S2383	13334.4	365
639	S2382	13323.4	185
640	S2381	13312.4	275
641	S2380	13301.4	365
642	S2379	13290.4	185
643	S2378	13279.4	275
644	S2377	13268.4	365
645	S2376	13257.4	185
646	S2375	13246.4	275
647	S2374	13235.4	365
648	S2373	13224.4	185
649	S2372	13213.4	275
650	S2371	13202.4	365
651	S2370	13191.4	185
652	S2369	13180.4	275
653	S2368	13169.4	365
654	S2367	13158.4	185
655	S2366	13147.4	275
656	S2365	13136.4	365
657	S2364	13125.4	185
658	S2363	13114.4	275
659	S2362	13103.4	365
660	S2361	13092.4	185
661	S2360	13081.4	275
662	S2359	13070.4	365
663	S2358	13059.4	185
664	S2357	13048.4	275
665	S2356	13037.4	365
666	S2355	13026.4	185
667	S2354	13015.4	275
668	S2353	13004.4	365
669	S2352	12993.4	185
670	S2351	12982.4	275
671	S2350	12971.4	365
672	S2349	12960.4	185
673	S2348	12949.4	275
674	S2347	12938.4	365
675	S2346	12927.4	185
676	S2345	12916.4	275
677	S2344	12905.4	365
678	S2343	12894.4	185
679	S2342	12883.4	275
680	S2341	12872.4	365
681	S2340	12861.4	185
682	S2339	12850.4	275
683	S2338	12839.4	365
684	S2337	12828.4	185
685	S2336	12817.4	275
686	S2335	12806.4	365
687	S2334	12795.4	185
688	S2333	12784.4	275
689	S2332	12773.4	365
690	S2331	12762.4	185
691	S2330	12751.4	275
692	S2329</		

No.	Name	X	Y
801	S2220	11541.87	185
802	S2219	11530.88	275
803	S2218	11519.88	365
804	S2217	11508.88	455
805	S2216	11497.88	545
806	S2215	11486.89	635
807	S2214	11475.89	725
808	S2213	11464.89	815
809	S2212	11453.89	905
810	S2211	11442.9	995
811	S2210	11431.9	1085
812	S2209	11420.9	1175
813	S2208	11409.9	1265
814	S2207	11398.91	1355
815	S2206	11387.91	1445
816	S2205	11376.91	1535
817	S2204	11365.91	1625
818	S2203	11354.92	1715
819	S2202	11343.92	1805
820	S2201	11332.92	1895
821	S2200	11321.92	1985
822	S2199	11310.93	2075
823	S2198	11299.93	2165
824	S2197	11288.93	2255
825	S2196	11277.93	2345
826	S2195	11266.94	2435
827	S2194	11255.94	2525
828	S2193	11244.94	2615
829	S2192	11233.94	2705
830	S2191	11222.95	2795
831	S2190	11211.95	2885
832	S2189	11200.95	2975
833	S2188	11189.95	3065
834	S2187	11178.95	3155
835	S2186	11167.96	3245
836	S2185	11156.96	3335
837	S2184	11145.96	3425
838	S2183	11134.97	3515
839	S2182	11123.97	3605
840	S2181	11112.97	3695
841	S2180	11101.97	3785
842	S2179	11090.98	3875
843	S2178	11079.98	3965
844	S2177	11068.98	4055
845	S2176	11057.98	4145
846	S2175	11046.99	4235
847	S2174	11035.99	4325
848	S2173	11024.99	4415
849	S2172	11013.99	4505
850	S2171	11003	4595
851	S2170	10992	4685
852	S2169	10981	4775
853	S2168	10970	4865
854	S2167	10959.01	4955
855	S2166	10948.01	5045
856	S2165	10937.01	5135
857	S2164	10926.01	5225
858	S2163	10915.02	5315
859	S2162	10904.02	5405
860	S2161	10893.02	5495
861	S2160	10882.02	5585
862	S2159	10871.03	5675
863	S2158	10860.03	5765
864	S2157	10849.03	5855
865	S2156	10838.03	5945
866	S2155	10827.04	6035
867	S2154	10816.04	6125
868	S2153	10805.04	6215
869	S2152	10794.04	6305
870	S2151	10783.05	6395
871	S2150	10772.05	6485
872	S2149	10761.05	6575
873	S2148	10750.05	6665
874	S2147	10739.06	6755
875	S2146	10728.06	6845
876	S2145	10717.06	6935
877	S2144	10706.06	7025
878	S2143	10695.07	7115
879	S2142	10684.07	7205
880	S2141	10673.07	7295
881	S2140	10662.07	7385
882	S2139	10651.08	7475
883	S2138	10640.08	7565
884	S2137	10629.08	7655
885	S2136	10618.08	7745
886	S2135	10607.09	7835
887	S2134	10596.09	7925
888	S2133	10585.09	8015
889	S2132	10574.09	8105
890	S2131	10563.1	8195
891	S2130	10552.1	8285
892	S2129	10541.1	8375
893	S2128	10530.1	8465
894	S2127	10519.11	8555
895	S2126	10508.11	8645
896	S2125	10497.11	8735
897	S2124	10486.11	8825
898	S2123	10475.12	8915
899	S2122	10464.12	9005
900	S2121	10453.12	9095

No.	Name	X	Y
901	S2120	10442.12	9185
902	S2119	10431.13	9275
903	S2118	10420.13	9365
904	S2117	10409.13	9455
905	S2116	10398.13	9545
906	S2115	10387.14	9635
907	S2114	10376.14	9725
908	S2113	10365.14	9815
909	S2112	10354.14	9905
910	S2111	10343.15	9995
911	S2110	10332.15	10085
912	S2109	10321.15	10175
913	S2108	10310.15	10265
914	S2107	10299.16	10355
915	S2106	10288.16	10445
916	S2105	10277.16	10535
917	S2104	10266.16	10625
918	S2103	10255.17	10715
919	S2102	10244.17	10805
920	S2101	10233.17	10895
921	S2100	10222.17	10985
922	S2099	10211.18	11075
923	S2098	10200.18	11165
924	S2097	10189.18	11255
925	S2096	10178.18	11345
926	S2095	10167.19	11435
927	S2094	10156.19	11525
928	S2093	10145.19	11615
929	S2092	10134.19	11705
930	S2091	10123.2	11795
931	S2090	10112.2	11885
932	S2089	10101.2	11975
933	S2088	10090.2	12065
934	S2087	10079.21	12155
935	S2086	10068.21	12245
936	S2085	10057.21	12335
937	S2084	10046.21	12425
938	S2083	10035.22	12515
939	S2082	10024.22	12605
940	S2081	10013.22	12695
941	S2080	10002.22	12785
942	S2079	9991.23	12875
943	S2078	9980.23	12965
944	S2077	9969.23	13055
945	S2076	9958.23	13145
946	S2075	9947.24	13235
947	S2074	9936.24	13325
948	S2073	9925.24	13415
949	S2072	9914.24	13505
950	S2071	9903.25	13595
951	S2070	9892.25	13685
952	S2069	9881.25	13775
953	S2068	9870.25	13865
954	S2067	9859.26	13955
955	S2066	9848.26	14045
956	S2065	9837.26	14135
957	S2064	9826.26	14225
958	S2063	9815.27	14315
959	S2062	9804.27	14405
960	S2061	9793.27	14495
961	S2060	9782.27	14585
962	S2059	9771.28	14675
963	S2058	9760.28	14765
964	S2057	9749.28	14855
965	S2056	9738.28	14945
966	S2055	9727.29	15035
967	S2054	9716.29	15125
968	S2053	9705.29	15215
969	S2052	9694.29	15305
970	S2051	9683.3	15395
971	S2050	9672.3	15485
972	S2049	9661.3	15575
973	S2048	9650.3	15665
974	S2047	9639.31	15755
975	S2046	9628.31	15845
976	S2045	9617.31	15935
977	S2044	9606.31	16025
978	S2043	9595.32	16115
979	S2042	9584.32	16205
980	S2041	9573.32	16295
981	S2040	9562.32	16385
982	S2039	9551.33	16475
983	S2038	9540.33	16565
984	S2037	9529.33	16655
985	S2036	9518.33	16745
986	S2035	9507.34	16835
987	S2034	9496.34	16925
988	S2033	9485.34	17015
989	S2032	9474.34	17105
990	S2031	9463.35	17195
991	S2030	9452.35	17285
992	S2029	9441.35	17375
993	S2028	9430.35	17465
994	S2027	9419.36	17555
995	S2026	9408.36	17645
996	S2025	9397.36	17735
997	S2024	9386.36	17825
998	S2023	9375.37	17915
999	S2022	9364.37	18005
1000	S2021	9353.37	18095

No.	Name	X	Y
1001	S2020	9342.37	18185
1002	S2019	9331.38	18275
1003	S2018	9320.38	18365
1004	S2017	9309.38	18455
1005	S2016	9298.38	18545
1006	S2015	9287.39	18635
1007	S2014	9276.39	18725
1008	S2013	9265.39	18815
1009	S2012	9254.39	18905
1010	S2011	9243.4	18995
1011	S2010	9232.4	19085
1012	S2009	9221.4	19175
1013	S2008	9210.4	19265
1014	S2007	9199.41	19355
1015	S2006	9188.41	19445
1016	S2005	9177.41	19535
1017	S2004	9166.41	19625
1018	S2003	9155.42	19715
1019	S2002	9144.42	19805
1020	S2001	9133.42	19895
1021	S2000	9122.42	19985
1022	S1999	9111.43	20075
1023	S1998	9100.43	20165
1024	S1997	9089.43	20255
1025	S1996	9078.43	20345
1026	S1995	9067.44	20435
1027	S1994	9056.44	20525
1028	S1993	9045.44	20615
1029	S1992	9034.44	20705
1030	S1991	9023.45	20795
1031	S1990	9012.45	20885
1032	S1989	9001.45	20975
1033	S1988	8990.45	21065
1034	S1987	8979.46	21155
1035	S1986	8968.46	21245
1036	S1985	8957.46	21335
1037	S1984	8946.46	21425
1038	S1983	8935.47	21515
1039	S1982	8924.47	21605
1040	S1981	8913.47	21695
1041	S1980	8902.47	21785
1042	S1979	8891.48	21875
1043	S1978	8880.48	21965
1044	S1977	8869.48	22055
1045	S1976	8858.48	22145
1046	S1975	8847.49	22235
1047	S1974	8836.49	22325
1048	S1973	8825.49	22415
1049	S1972	8814.49	22505
1050	S1971	8803.5	22595
1051	S1970	8792.5	22685
1052	S1969	8781.5	22775
1053	S1968	8770.5	22865
1054	S1967	8759.51	22955
1055	S1966	8748.51	23045
1056	S1965	8737.51	23135
1057	S1964	8726.51	23225
1058	S1963	8715.52	23315
1059	S1962	8704.52	23405
1060	S1961	8693.52	23495
1061	S1960	8682.52	23585
1062	S1959	8671.53	23675
1063	S1958	8660.53	23765
1064	S1957	8649.53	23855
1065	S1956	8638.53	23945
1066	S1955	8627.54	24035
1067	S1954	8616.54	24125
1068	S1953	8605.54	24215
1069	S1952	8594.54	24305
1070	S1951	8583.55	24395
1071	S1950	8	

No.	Name	X	Y
1201	S1820	7142.87	275
1202	S1819	7131.88	365
1203	S1818	7120.88	185
1204	S1817	7109.88	275
1205	S1816	7098.88	365
1206	S1815	7087.89	185
1207	S1814	7076.89	275
1208	S1813	7065.89	365
1209	S1812	7054.89	185
1210	S1811	7043.9	275
1211	S1810	7032.9	365
1212	S1809	7021.9	185
1213	S1808	7010.9	275
1214	S1807	6999.91	365
1215	S1806	6988.91	185
1216	S1805	6977.91	275
1217	S1804	6966.91	365
1218	S1803	6955.92	185
1219	S1802	6944.92	275
1220	S1801	6933.92	365
1221	DUMMY11	6922.92	185
1222	DUMMY12	6911.93	275
1223	DUMMY13	6900.93	365
1224	DUMMY14	6889.93	185
1225	DUMMY15	6878.93	275
1226	DUMMY16	6867.94	365
1227	DUMMY17	6856.94	185
1228	DUMMY18	6845.94	275
1229	DUMMY19	6834.94	365
1230	DUMMY20	6823.95	185
1231	DUMMY21	6812.95	275
1232	DUMMY22	6801.95	365
1233	DUMMY23	6790.95	185
1234	DUMMY24	6779.96	275
1235	DUMMY25	6768.96	365
1236	DUMMY26	6757.96	185
1237	DUMMY27	6746.96	275
1238	DUMMY28	6735.97	365
1239	S1800	6724.97	185
1240	S1799	6713.97	275
1241	S1798	6702.97	365
1242	S1797	6691.98	185
1243	S1796	6680.98	275
1244	S1795	6669.98	365
1245	S1794	6658.98	185
1246	S1793	6647.99	275
1247	S1792	6636.99	365
1248	S1791	6625.99	185
1249	S1790	6614.99	275
1250	S1789	6604	365
1251	S1788	6593	185
1252	S1787	6582	275
1253	S1786	6571	365
1254	S1785	6560.01	185
1255	S1784	6549.01	275
1256	S1783	6538.01	365
1257	S1782	6527.01	185
1258	S1781	6516.02	275
1259	S1780	6505.02	365
1260	S1779	6494.02	185
1261	S1778	6483.02	275
1262	S1777	6472.03	365
1263	S1776	6461.03	185
1264	S1775	6450.03	275
1265	S1774	6439.03	365
1266	S1773	6428.04	185
1267	S1772	6417.04	275
1268	S1771	6406.04	365
1269	S1770	6395.04	185
1270	S1769	6384.05	275
1271	S1768	6373.05	365
1272	S1767	6362.05	185
1273	S1766	6351.05	275
1274	S1765	6340.06	365
1275	S1764	6329.06	185
1276	S1763	6318.06	275
1277	S1762	6307.06	365
1278	S1761	6296.07	185
1279	S1760	6285.07	275
1280	S1759	6274.07	365
1281	S1758	6263.07	185
1282	S1757	6252.08	275
1283	S1756	6241.08	365
1284	S1755	6230.08	185
1285	S1754	6219.08	275
1286	S1753	6208.09	365
1287	S1752	6197.09	185
1288	S1751	6186.09	275
1289	S1750	6175.09	365
1290	S1749	6164.1	185
1291	S1748	6153.1	275
1292	S1747	6142.1	365
1293	S1746	6131.1	185
1294	S1745	6120.11	275
1295	S1744	6109.11	365
1296	S1743	6098.11	185
1297	S1742	6087.11	275
1298	S1741	6076.12	365
1299	S1740	6065.12	185
1300	S1739	6054.12	275

No.	Name	X	Y
1301	S1738	6043.12	365
1302	S1737	6032.13	185
1303	S1736	6021.13	275
1304	S1735	6010.13	365
1305	S1734	5999.13	185
1306	S1733	5988.14	275
1307	S1732	5977.14	365
1308	S1731	5966.14	185
1309	S1730	5955.14	275
1310	S1729	5944.15	365
1311	S1728	5933.15	185
1312	S1727	5922.15	275
1313	S1726	5911.15	365
1314	S1725	5900.16	185
1315	S1724	5889.16	275
1316	S1723	5878.16	365
1317	S1722	5867.16	185
1318	S1721	5856.17	275
1319	S1720	5845.17	365
1320	S1719	5834.17	185
1321	S1718	5823.17	275
1322	S1717	5812.18	365
1323	S1716	5801.18	185
1324	S1715	5790.18	275
1325	S1714	5779.18	365
1326	S1713	5768.19	185
1327	S1712	5757.19	275
1328	S1711	5746.19	365
1329	S1710	5735.19	185
1330	S1709	5724.2	275
1331	S1708	5713.2	365
1332	S1707	5702.2	185
1333	S1706	5691.2	275
1334	S1705	5680.21	365
1335	S1704	5669.21	185
1336	S1703	5658.21	275
1337	S1702	5647.21	365
1338	S1701	5636.22	185
1339	S1700	5625.22	275
1340	S1699	5614.22	365
1341	S1698	5603.22	185
1342	S1697	5592.23	275
1343	S1696	5581.23	365
1344	S1695	5570.23	185
1345	S1694	5559.23	275
1346	S1693	5548.24	365
1347	S1692	5537.24	185
1348	S1691	5526.24	275
1349	S1690	5515.24	365
1350	S1689	5504.25	185
1351	S1688	5493.25	275
1352	S1687	5482.25	365
1353	S1686	5471.25	185
1354	S1685	5460.26	275
1355	S1684	5449.26	365
1356	S1683	5438.26	185
1357	S1682	5427.26	275
1358	S1681	5416.27	365
1359	S1680	5405.27	185
1360	S1679	5394.27	275
1361	S1678	5383.27	365
1362	S1677	5372.28	185
1363	S1676	5361.28	275
1364	S1675	5350.28	365
1365	S1674	5339.28	185
1366	S1673	5328.29	275
1367	S1672	5317.29	365
1368	S1671	5306.29	185
1369	S1670	5295.29	275
1370	S1669	5284.3	365
1371	S1668	5273.3	185
1372	S1667	5262.3	275
1373	S1666	5251.3	365
1374	S1665	5240.31	185
1375	S1664	5229.31	275
1376	S1663	5218.31	365
1377	S1662	5207.31	185
1378	S1661	5196.32	275
1379	S1660	5185.32	365
1380	S1659	5174.32	185
1381	S1658	5163.32	275
1382	S1657	5152.33	365
1383	S1656	5141.33	185
1384	S1655	5130.33	275
1385	S1654	5119.33	365
1386	S1653	5108.34	185
1387	S1652	5097.34	275
1388	S1651	5086.34	365
1389	S1650	5075.34	185
1390	S1649	5064.35	275
1391	S1648	5053.35	365
1392	S1647	5042.35	185
1393	S1646	5031.35	275
1394	S1645	5020.36	365
1395	S1644	5009.36	185
1396	S1643	4998.36	275
1397	S1642	4987.36	365
1398	S1641	4976.37	185
1399	S1640	4965.37	275
1400	S1639	4954.37	365

No.	Name	X	Y
1401	S1638	4943.37	185
1402	S1637	4932.38	275
1403	S1636	4921.38	365
1404	S1635	4910.38	185
1405	S1634	4899.38	275
1406	S1633	4888.39	365
1407	S1632	4877.39	185
1408	S1631	4866.39	275
1409	S1630	4855.39	365
1410	S1629	4844.4	185
1411	S1628	4833.4	275
1412	S1627	4822.4	365
1413	S1626	4811.4	185
1414	S1625	4800.41	275
1415	S1624	4789.41	365
1416	S1623	4778.41	185
1417	S1622	4767.41	275
1418	S1621	4756.42	365
1419	S1620	4745.42	185
1420	S1619	4734.42	275
1421	S1618	4723.42	365
1422	S1617	4712.43	185
1423	S1616	4701.43	275
1424	S1615	4690.43	365
1425	S1614	4679.43	185
1426	S1613	4668.44	275
1427	S1612	4657.44	365
1428	S1611	4646.44	185
1429	S1610	4635.44	275
1430	S1609	4624.45	365
1431	S1608	4613.45	185
1432	S1607	4602.45	275
1433	S1606	4591.45	365
1434	S1605	4580.46	185
1435	S1604	4569.46	275
1436	S1603	4558.46	365
1437	S1602	4547.46	185
1438	S1601	4536.47	275
1439	S1600	4525.47	365
1440	S1599	4514.47	185
1441	S1598	4503.47	275
1442	S1597	4492.48	365
1443	S1596	4481.48	185
1444	S1595	4470.48	275
1445	S1594	4459.48	365
1446	S1593	4448.49	185
1447	S1592	4437.49	275
1448	S1591	4426.49	365
1449	S1590	4415.49	185
1450	S1589	4404.5	275
1451	S1588	4393.5	365
1452	S1587	4382.5	185
1453	S1586	4371.5	275
1454	S1585	4360.51	365
1455	S1584	4349.51	185
1456	S1583	4338.51	275
1457	S1582	4327.51	365
1458	S1581	4316.52	185
1459	S1580	4305.52	275
1460	S1579	4294.52	365
1461	S1578	4283.52	185
1462	S1577	4272.53	275
1463	S1576	4261.53	365
1464	S1575	4250.53	185
1465	S1574	4239.53	275
1466	S1573	4228.54	365
1467	S1572	4217.54	185
1468	S1571	4206.54	275
1469	S1570	4195.54	365
1470	S1569	4184.55	185
1471	S1568	4173.55	275
1472	S1567	4162.55	365
1473	S1566	4151.55	185
1474	S1565	4140.56	275
1475	S1564	4129.56	365
1476	S1563	4118.56	185
1477	S1562	4107.56	275
1478	S1561	4096.57	365
1479	S1560	4085.57	185

No.	Name	X	Y
1601	S1438	2743.87	365
1602	S1437	2732.88	185
1603	S1436	2721.88	275
1604	S1435	2710.88	365
1605	S1434	2699.88	185
1606	S1433	2688.89	275
1607	S1432	2677.89	365
1608	S1431	2666.89	185
1609	S1430	2655.89	275
1610	S1429	2644.9	365
1611	S1428	2633.9	185
1612	S1427	2622.9	275
1613	S1426	2611.9	365
1614	S1425	2600.91	185
1615	S1424	2589.91	275
1616	S1423	2578.91	365
1617	S1422	2567.91	185
1618	S1421	2556.92	275
1619	S1420	2545.92	365
1620	S1419	2534.92	185
1621	S1418	2523.92	275
1622	S1417	2512.93	365
1623	S1416	2501.93	185
1624	S1415	2490.93	275
1625	S1414	2479.93	365
1626	S1413	2468.94	185
1627	S1412	2457.94	275
1628	S1411	2446.94	365
1629	S1410	2435.94	185
1630	S1409	2424.95	275
1631	S1408	2413.95	365
1632	S1407	2402.95	185
1633	S1406	2391.95	275
1634	S1405	2380.96	365
1635	S1404	2369.96	185
1636	S1403	2358.96	275
1637	S1402	2347.96	365
1638	S1401	2336.97	185
1639	S1400	2325.97	275
1640	S1399	2314.97	365
1641	S1398	2303.97	185
1642	S1397	2292.98	275
1643	S1396	2281.98	365
1644	S1395	2270.98	185
1645	S1394	2259.98	275
1646	S1393	2248.99	365
1647	S1392	2237.99	185
1648	S1391	2226.99	275
1649	S1390	2215.99	365
1650	S1389	2205	185
1651	S1388	2194	275
1652	S1387	2183	365
1653	S1386	2172	185
1654	S1385	2161.01	275
1655	S1384	2150.01	365
1656	S1383	2139.01	185
1657	S1382	2128.01	275
1658	S1381	2117.02	365
1659	S1380	2106.02	185
1660	S1379	2095.02	275
1661	S1378	2084.02	365
1662	S1377	2073.03	185
1663	S1376	2062.03	275
1664	S1375	2051.03	365
1665	S1374	2040.03	185
1666	S1373	2029.04	275
1667	S1372	2018.04	365
1668	S1371	2007.04	185
1669	S1370	1996.04	275
1670	S1369	1985.05	365
1671	S1368	1974.05	185
1672	S1367	1963.05	275
1673	S1366	1952.05	365
1674	S1365	1941.06	185
1675	S1364	1930.06	275
1676	S1363	1919.06	365
1677	S1362	1908.06	185
1678	S1361	1897.07	275
1679	S1360	1886.07	365
1680	S1359	1875.07	185
1681	S1358	1864.07	275
1682	S1357	1853.08	365
1683	S1356	1842.08	185
1684	S1355	1831.08	275
1685	S1354	1820.08	365
1686	S1353	1809.09	185
1687	S1352	1798.09	275
1688	S1351	1787.09	365
1689	S1350	1776.09	185
1690	S1349	1765.1	275
1691	S1348	1754.1	365
1692	S1347	1743.1	185
1693	S1346	1732.1	275
1694	S1345	1721.11	365
1695	S1344	1710.11	185
1696	S1343	1699.11	275
1697	S1342	1688.11	365
1698	S1341	1677.12	185
1699	S1340	1666.12	275
1700	S1339	1655.12	365

No.	Name	X	Y
1701	S1338	1644.12	185
1702	S1337	1633.13	275
1703	S1336	1622.13	365
1704	S1335	1611.13	185
1705	S1334	1600.13	275
1706	S1333	1589.14	365
1707	S1332	1578.14	185
1708	S1331	1567.14	275
1709	S1330	1556.14	365
1710	S1329	1545.15	185
1711	S1328	1534.15	275
1712	S1327	1523.15	365
1713	S1326	1512.15	185
1714	S1325	1501.16	275
1715	S1324	1490.16	365
1716	S1323	1479.16	185
1717	S1322	1468.16	275
1718	S1321	1457.17	365
1719	S1320	1446.17	185
1720	S1319	1435.17	275
1721	S1318	1424.17	365
1722	S1317	1413.18	185
1723	S1316	1402.18	275
1724	S1315	1391.18	365
1725	S1314	1380.18	185
1726	S1313	1369.19	275
1727	S1312	1358.19	365
1728	S1311	1347.19	185
1729	S1310	1336.19	275
1730	S1309	1325.2	365
1731	S1308	1314.2	185
1732	S1307	1303.2	275
1733	S1306	1292.2	365
1734	S1305	1281.21	185
1735	S1304	1270.21	275
1736	S1303	1259.21	365
1737	S1302	1248.21	185
1738	S1301	1237.22	275
1739	S1300	1226.22	365
1740	S1299	1215.22	185
1741	S1298	1204.22	275
1742	S1297	1193.23	365
1743	S1296	1182.23	185
1744	S1295	1171.23	275
1745	S1294	1160.23	365
1746	S1293	1149.24	185
1747	S1292	1138.24	275
1748	S1291	1127.24	365
1749	S1290	1116.24	185
1750	S1289	1105.25	275
1751	S1288	1094.25	365
1752	S1287	1083.25	185
1753	S1286	1072.25	275
1754	S1285	1061.26	365
1755	S1284	1050.26	185
1756	S1283	1039.26	275
1757	S1282	1028.26	365
1758	S1281	1017.27	185
1759	S1280	1006.27	275
1760	S1279	995.27	365
1761	S1278	984.27	185
1762	S1277	973.28	275
1763	S1276	962.28	365
1764	S1275	951.28	185
1765	S1274	940.28	275
1766	S1273	929.29	365
1767	S1272	918.29	185
1768	S1271	907.29	275
1769	S1270	896.29	365
1770	S1269	885.3	185
1771	S1268	874.3	275
1772	S1267	863.3	365
1773	S1266	852.3	185
1774	S1265	841.31	275
1775	S1264	830.31	365
1776	S1263	819.31	185
1777	S1262	808.31	275
1778	S1261	797.32	365
1779	S1260	786.32	185
1780	S1259	775.32	275
1781	S1258	764.32	365
1782	S1257	753.33	185
1783	S1256	742.33	275
1784	S1255	731.33	365
1785	S1254	720.33	185
1786	S1253	709.34	275
1787	S1252	698.34	365
1788	S1251	687.34	185
1789	S1250	676.34	275
1790	S1249	665.35	365
1791	S1248	654.35	185
1792	S1247	643.35	275
1793	S1246	632.35	365
1794	S1245	621.36	185
1795	S1244	610.36	275
1796	S1243	599.36	365
1797	S1242	588.36	185
1798	S1241	577.37	275
1799	S1240	566.37	365
1800	S1239	555.37	185

No.	Name	X	Y
1801	S1238	544.37	275
1802	S1237	533.38	365
1803	S1236	522.38	185
1804	S1235	511.38	275
1805	S1234	500.38	365
1806	S1233	489.39	185
1807	S1232	478.39	275
1808	S1231	467.39	365
1809	S1230	456.39	185
1810	S1229	445.4	275
1811	S1228	434.4	365
1812	S1227	423.4	185
1813	S1226	412.4	275
1814	S1225	401.41	365
1815	S1224	390.41	185
1816	S1223	379.41	275
1817	S1222	368.41	365
1818	S1221	357.42	185
1819	S1220	346.42	275
1820	S1219	335.42	365
1821	S1218	324.42	185
1822	S1217	313.43	275
1823	S1216	302.43	365
1824	S1215	291.43	185
1825	S1214	280.43	275
1826	S1213	269.44	365
1827	S1212	258.44	185
1828	S1211	247.44	275
1829	S1210	236.44	365
1830	S1209	225.45	185
1831	S1208	214.45	275
1832	S1207	203.45	365
1833	S1206	192.45	185
1834	S1205	181.46	275
1835	S1204	170.46	365
1836	S1203	159.46	185
1837	S1202	148.46	275
1838	S1201	137.47	365
1839	DUMMY29	126.47	185
1840	DUMMY30	115.47	275
1841	DUMMY31	104.47	365
1842	DUMMY32	93.48	185
1843	DUMMY33	82.48	275
1844	DUMMY34	71.48	365
1845	DUMMY35	60.48	185
1846	DUMMY36	49.49	275
1847	DUMMY37	38.49	365
1848	DUMMY38	27.49	185
1849	DUMMY39	16.49	275
1850	DUMMY40	5.5	365
1851	DUMMY41	-5.5	185
1852	DUMMY42	-16.49	275
1853	DUMMY43	-27.49	365
1854	DUMMY44	-38.49	185
1855	DUMMY45	-49.49	275
1856	DUMMY46	-60.48	365
1857	DUMMY47	-71.48	185
1858	DUMMY48	-82.48	275
1859	DUMMY49	-93.48	365
1860	DUMMY50	-104.47	185
1861	DUMMY51	-115.47	275
1862	DUMMY52	-126.47	365
1863	S1200	-137.47	185
1864	S1199	-148.46	275
1865	S1198	-159.46	365
1866	S1197	-170.46	185
1867	S1196	-181.46	275
1868	S1195	-192.45	365
1869	S1194	-203.45	185
1870	S1193	-214.45	275
1871	S1192	-225.45	365
1872	S1191	-236.44	185
1873	S1190	-247.44	275
1874	S1189	-258.44	365
1875	S1188	-269.44	185
1876	S1187	-280.43	275
1877	S1186	-291.43	365
1878	S1185	-302.43	185
1879	S1184	-313.43	275
1880	S1183	-324.42	365
1881	S1182	-335.42	185
1882	S1181	-346.42	275
1883	S1180	-357.42	3

No.	Name	X	Y
2001	S1062	-1655.12	185
2002	S1061	-1666.12	275
2003	S1060	-1677.12	365
2004	S1059	-1688.11	185
2005	S1058	-1699.11	275
2006	S1057	-1710.11	365
2007	S1056	-1721.11	185
2008	S1055	-1732.1	275
2009	S1054	-1743.1	365
2010	S1053	-1754.1	185
2011	S1052	-1765.1	275
2012	S1051	-1776.09	365
2013	S1050	-1787.09	185
2014	S1049	-1798.09	275
2015	S1048	-1809.09	365
2016	S1047	-1820.08	185
2017	S1046	-1831.08	275
2018	S1045	-1842.08	365
2019	S1044	-1853.08	185
2020	S1043	-1864.07	275
2021	S1042	-1875.07	365
2022	S1041	-1886.07	185
2023	S1040	-1897.07	275
2024	S1039	-1908.06	365
2025	S1038	-1919.06	185
2026	S1037	-1930.06	275
2027	S1036	-1941.06	365
2028	S1035	-1952.05	185
2029	S1034	-1963.05	275
2030	S1033	-1974.05	365
2031	S1032	-1985.05	185
2032	S1031	-1996.04	275
2033	S1030	-2007.04	365
2034	S1029	-2018.04	185
2035	S1028	-2029.04	275
2036	S1027	-2040.03	365
2037	S1026	-2051.03	185
2038	S1025	-2062.03	275
2039	S1024	-2073.03	365
2040	S1023	-2084.02	185
2041	S1022	-2095.02	275
2042	S1021	-2106.02	365
2043	S1020	-2117.02	185
2044	S1019	-2128.01	275
2045	S1018	-2139.01	365
2046	S1017	-2150.01	185
2047	S1016	-2161.01	275
2048	S1015	-2172	365
2049	S1014	-2183	185
2050	S1013	-2194	275
2051	S1012	-2205	365
2052	S1011	-2215.99	185
2053	S1010	-2226.99	275
2054	S1009	-2237.99	365
2055	S1008	-2248.99	185
2056	S1007	-2259.98	275
2057	S1006	-2270.98	365
2058	S1005	-2281.98	185
2059	S1004	-2292.98	275
2060	S1003	-2303.97	365
2061	S1002	-2314.97	185
2062	S1001	-2325.97	275
2063	S1000	-2336.97	365
2064	S999	-2347.96	185
2065	S998	-2358.96	275
2066	S997	-2369.96	365
2067	S996	-2380.96	185
2068	S995	-2391.95	275
2069	S994	-2402.95	365
2070	S993	-2413.95	185
2071	S992	-2424.95	275
2072	S991	-2435.94	365
2073	S990	-2446.94	185
2074	S989	-2457.94	275
2075	S988	-2468.94	365
2076	S987	-2479.93	185
2077	S986	-2490.93	275
2078	S985	-2501.93	365
2079	S984	-2512.93	185
2080	S983	-2523.92	275
2081	S982	-2534.92	365
2082	S981	-2545.92	185
2083	S980	-2556.92	275
2084	S979	-2567.91	365
2085	S978	-2578.91	185
2086	S977	-2589.91	275
2087	S976	-2600.91	365
2088	S975	-2611.9	185
2089	S974	-2622.9	275
2090	S973	-2633.9	365
2091	S972	-2644.9	185
2092	S971	-2655.89	275
2093	S970	-2666.89	365
2094	S969	-2677.89	185
2095	S968	-2688.89	275
2096	S967	-2699.88	365
2097	S966	-2710.88	185
2098	S965	-2721.88	275
2099	S964	-2732.88	365
2100	S963	-2743.87	185

No.	Name	X	Y
2101	S962	-2754.87	275
2102	S961	-2765.87	365
2103	S960	-2776.87	185
2104	S959	-2787.86	275
2105	S958	-2798.86	365
2106	S957	-2809.86	185
2107	S956	-2820.86	275
2108	S955	-2831.85	365
2109	S954	-2842.85	185
2110	S953	-2853.85	275
2111	S952	-2864.85	365
2112	S951	-2875.84	185
2113	S950	-2886.84	275
2114	S949	-2897.84	365
2115	S948	-2908.84	185
2116	S947	-2919.83	275
2117	S946	-2930.83	365
2118	S945	-2941.83	185
2119	S944	-2952.83	275
2120	S943	-2963.82	365
2121	S942	-2974.82	185
2122	S941	-2985.82	275
2123	S940	-2996.82	365
2124	S939	-3007.81	185
2125	S938	-3018.81	275
2126	S937	-3029.81	365
2127	S936	-3040.81	185
2128	S935	-3051.8	275
2129	S934	-3062.8	365
2130	S933	-3073.8	185
2131	S932	-3084.8	275
2132	S931	-3095.79	365
2133	S930	-3106.79	185
2134	S929	-3117.79	275
2135	S928	-3128.79	365
2136	S927	-3139.78	185
2137	S926	-3150.78	275
2138	S925	-3161.78	365
2139	S924	-3172.78	185
2140	S923	-3183.77	275
2141	S922	-3194.77	365
2142	S921	-3205.77	185
2143	S920	-3216.77	275
2144	S919	-3227.76	365
2145	S918	-3238.76	185
2146	S917	-3249.76	275
2147	S916	-3260.76	365
2148	S915	-3271.75	185
2149	S914	-3282.75	275
2150	S913	-3293.75	365
2151	S912	-3304.75	185
2152	S911	-3315.74	275
2153	S910	-3326.74	365
2154	S909	-3337.74	185
2155	S908	-3348.74	275
2156	S907	-3359.73	365
2157	S906	-3370.73	185
2158	S905	-3381.73	275
2159	S904	-3392.73	365
2160	S903	-3403.72	185
2161	S902	-3414.72	275
2162	S901	-3425.72	365
2163	S900	-3436.72	185
2164	S899	-3447.71	275
2165	S898	-3458.71	365
2166	S897	-3469.71	185
2167	S896	-3480.71	275
2168	S895	-3491.7	365
2169	S894	-3502.7	185
2170	S893	-3513.7	275
2171	S892	-3524.7	365
2172	S891	-3535.69	185
2173	S890	-3546.69	275
2174	S889	-3557.69	365
2175	S888	-3568.69	185
2176	S887	-3579.68	275
2177	S886	-3590.68	365
2178	S885	-3601.68	185
2179	S884	-3612.68	275
2180	S883	-3623.67	365
2181	S882	-3634.67	185
2182	S881	-3645.67	275
2183	S880	-3656.67	365
2184	S879	-3667.66	185
2185	S878	-3678.66	275
2186	S877	-3689.66	365
2187	S876	-3700.66	185
2188	S875	-3711.65	275
2189	S874	-3722.65	365
2190	S873	-3733.65	185
2191	S872	-3744.65	275
2192	S871	-3755.64	365
2193	S870	-3766.64	185
2194	S869	-3777.64	275
2195	S868	-3788.64	365
2196	S867	-3799.63	185
2197	S866	-3810.63	275
2198	S865	-3821.63	365
2199	S864	-3832.63	185
2200	S863	-3843.62	275

No.	Name	X	Y
2201	S862	-3854.62	365
2202	S861	-3865.62	185
2203	S860	-3876.62	275
2204	S859	-3887.61	365
2205	S858	-3898.61	185
2206	S857	-3909.61	275
2207	S856	-3920.61	365
2208	S855	-3931.6	185
2209	S854	-3942.6	275
2210	S853	-3953.6	365
2211	S852	-3964.6	185
2212	S851	-3975.59	275
2213	S850	-3986.59	365
2214	S849	-3997.59	185
2215	S848	-4008.59	275
2216	S847	-4019.58	365
2217	S846	-4030.58	185
2218	S845	-4041.58	275
2219	S844	-4052.58	365
2220	S843	-4063.57	185
2221	S842	-4074.57	275
2222	S841	-4085.57	365
2223	S840	-4096.57	185
2224	S839	-4107.56	275
2225	S838	-4118.56	365
2226	S837	-4129.56	185
2227	S836	-4140.56	275
2228	S835	-4151.55	365
2229	S834	-4162.55	185
2230	S833	-4173.55	275
2231	S832	-4184.55	365
2232	S831	-4195.54	185
2233	S830	-4206.54	275
2234	S829	-4217.54	365
2235	S828	-4228.54	185
2236	S827	-4239.53	275
2237	S826	-4250.53	365
2238	S825	-4261.53	185
2239	S824	-4272.53	275
2240	S823	-4283.52	365
2241	S822	-4294.52	185
2242	S821	-4305.52	275
2243	S820	-4316.52	365
2244	S819	-4327.51	185
2245	S818	-4338.51	275
2246	S817	-4349.51	365
2247	S816	-4360.51	185
2248	S815	-4371.5	275
2249	S814	-4382.5	365
2250	S813	-4393.5	185
2251	S812	-4404.5	275
2252	S811	-4415.49	365
2253	S810	-4426.49	185
2254	S809	-4437.49	275
2255	S808	-4448.49	365
2256	S807	-4459.48	185
2257	S806	-4470.48	275
2258	S805	-4481.48	365
2259	S804	-4492.48	185
2260	S803	-4503.47	275
2261	S802	-4514.47	365
2262	S801	-4525.47	185
2263	S800	-4536.47	275
2264	S799	-4547.46	365
2265	S798	-4558.46	185
2266	S797	-4569.46	275
2267	S796	-4580.46	365
2268	S795	-4591.45	185
2269	S794	-4602.45	275
2270	S793	-4613.45	365
2271	S792	-4624.45	185
2272	S791	-4635.44	275
2273	S790	-4646.44	365
2274	S789	-4657.44	185
2275	S788	-4668.44	275
2276	S787	-4679.43	365
2277	S786	-4690.43	185
2278	S785	-4701.43	275
2279	S784	-4712.43	365
2280	S783	-4723.42	185
2281	S782	-4734.42	275
2282	S781	-4745.42	365
2283	S780	-4756.42	185
2284	S779	-4767.41	275

No.	Name	X	Y
2401	S662	-6054.12	275
2402	S661	-6065.12	365
2403	S660	-6076.12	185
2404	S659	-6087.11	275
2405	S658	-6098.11	365
2406	S657	-6109.11	185
2407	S656	-6120.11	275
2408	S655	-6131.1	365
2409	S654	-6142.1	185
2410	S653	-6153.1	275
2411	S652	-6164.1	365
2412	S651	-6175.09	185
2413	S650	-6186.09	275
2414	S649	-6197.09	365
2415	S648	-6208.09	185
2416	S647	-6219.08	275
2417	S646	-6230.08	365
2418	S645	-6241.08	185
2419	S644	-6252.08	275
2420	S643	-6263.07	365
2421	S642	-6274.07	185
2422	S641	-6285.07	275
2423	S640	-6296.07	365
2424	S639	-6307.06	185
2425	S638	-6318.06	275
2426	S637	-6329.06	365
2427	S636	-6340.06	185
2428	S635	-6351.05	275
2429	S634	-6362.05	365
2430	S633	-6373.05	185
2431	S632	-6384.05	275
2432	S631	-6395.04	365
2433	S630	-6406.04	185
2434	S629	-6417.04	275
2435	S628	-6428.04	365
2436	S627	-6439.03	185
2437	S626	-6450.03	275
2438	S625	-6461.03	365
2439	S624	-6472.03	185
2440	S623	-6483.02	275
2441	S622	-6494.02	365
2442	S621	-6505.02	185
2443	S620	-6516.02	275
2444	S619	-6527.01	365
2445	S618	-6538.01	185
2446	S617	-6549.01	275
2447	S616	-6560.01	365
2448	S615	-6571.01	185
2449	S614	-6582.01	275
2450	S613	-6593.01	365
2451	S612	-6604.01	185
2452	S611	-6614.99	275
2453	S610	-6625.99	365
2454	S609	-6636.99	185
2455	S608	-6647.99	275
2456	S607	-6658.98	365
2457	S606	-6669.98	185
2458	S605	-6680.98	275
2459	S604	-6691.98	365
2460	S603	-6702.97	185
2461	S602	-6713.97	275
2462	S601	-6724.97	365
2463	DUMMY53	-6735.97	185
2464	DUMMY54	-6746.96	275
2465	DUMMY55	-6757.96	365
2466	DUMMY56	-6768.96	185
2467	DUMMY57	-6779.96	275
2468	DUMMY58	-6790.95	365
2469	DUMMY59	-6801.95	185
2470	DUMMY60	-6812.95	275
2471	DUMMY61	-6823.95	365
2472	DUMMY62	-6834.94	185
2473	DUMMY63	-6845.94	275
2474	DUMMY64	-6856.94	365
2475	DUMMY65	-6867.94	185
2476	DUMMY66	-6878.93	275
2477	DUMMY67	-6889.93	365
2478	DUMMY68	-6900.93	185
2479	DUMMY69	-6911.93	275
2480	DUMMY70	-6922.92	365
2481	S600	-6933.92	185
2482	S599	-6944.92	275
2483	S598	-6955.92	365
2484	S597	-6966.91	185
2485	S596	-6977.91	275
2486	S595	-6988.91	365
2487	S594	-6999.91	185
2488	S593	-7010.9	275
2489	S592	-7021.9	365
2490	S591	-7032.9	185
2491	S590	-7043.9	275
2492	S589	-7054.89	365
2493	S588	-7065.89	185
2494	S587	-7076.89	275
2495	S586	-7087.89	365
2496	S585	-7098.88	185
2497	S584	-7109.88	275
2498	S583	-7120.88	365
2499	S582	-7131.88	185
2500	S581	-7142.87	275

No.	Name	X	Y
2501	S580	-7153.87	365
2502	S579	-7164.87	185
2503	S578	-7175.87	275
2504	S577	-7186.86	365
2505	S576	-7197.86	185
2506	S575	-7208.86	275
2507	S574	-7219.86	365
2508	S573	-7230.85	185
2509	S572	-7241.85	275
2510	S571	-7252.85	365
2511	S570	-7263.85	185
2512	S569	-7274.84	275
2513	S568	-7285.84	365
2514	S567	-7296.84	185
2515	S566	-7307.84	275
2516	S565	-7318.83	365
2517	S564	-7329.83	185
2518	S563	-7340.83	275
2519	S562	-7351.83	365
2520	S561	-7362.82	185
2521	S560	-7373.82	275
2522	S559	-7384.82	365
2523	S558	-7395.82	185
2524	S557	-7406.81	275
2525	S556	-7417.81	365
2526	S555	-7428.81	185
2527	S554	-7439.81	275
2528	S553	-7450.8	365
2529	S552	-7461.8	185
2530	S551	-7472.8	275
2531	S550	-7483.8	365
2532	S549	-7494.79	185
2533	S548	-7505.79	275
2534	S547	-7516.79	365
2535	S546	-7527.79	185
2536	S545	-7538.78	275
2537	S544	-7549.78	365
2538	S543	-7560.78	185
2539	S542	-7571.78	275
2540	S541	-7582.77	365
2541	S540	-7593.77	185
2542	S539	-7604.77	275
2543	S538	-7615.77	365
2544	S537	-7626.76	185
2545	S536	-7637.76	275
2546	S535	-7648.76	365
2547	S534	-7659.76	185
2548	S533	-7670.75	275
2549	S532	-7681.75	365
2550	S531	-7692.75	185
2551	S530	-7703.75	275
2552	S529	-7714.74	365
2553	S528	-7725.74	185
2554	S527	-7736.74	275
2555	S526	-7747.74	365
2556	S525	-7758.73	185
2557	S524	-7769.73	275
2558	S523	-7780.73	365
2559	S522	-7791.73	185
2560	S521	-7802.72	275
2561	S520	-7813.72	365
2562	S519	-7824.72	185
2563	S518	-7835.72	275
2564	S517	-7846.71	365
2565	S516	-7857.71	185
2566	S515	-7868.71	275
2567	S514	-7879.71	365
2568	S513	-7890.7	185
2569	S512	-7901.7	275
2570	S511	-7912.7	365
2571	S510	-7923.7	185
2572	S509	-7934.69	275
2573	S508	-7945.69	365
2574	S507	-7956.69	185
2575	S506	-7967.69	275
2576	S505	-7978.68	365
2577	S504	-7989.68	185
2578	S503	-8000.68	275
2579	S502	-8011.68	365
2580	S501	-8022.67	185
2581	S500	-8033.67	275
2582	S499	-8044.67	365
2583	S498	-8055.67	185
2584	S497	-8066.66	275
2585	S496	-8077.66	365
2586	S495	-8088.66	185
2587	S494	-8099.66	275
2588	S493	-8110.65	365
2589	S492	-8121.65	185
2590	S491	-8132.65	275
2591	S490	-8143.65	365
2592	S489	-8154.64	185
2593	S488	-8165.64	275
2594	S487	-8176.64	365
2595	S486	-8187.64	185
2596	S485	-8198.63	275
2597	S484	-8209.63	365
2598	S483	-8220.63	185
2599	S482	-8231.63	275
2600	S481	-8242.62	365

No.	Name	X	Y
2601	S480	-8253.62	185
2602	S479	-8264.62	275
2603	S478	-8275.62	365
2604	S477	-8286.61	185
2605	S476	-8297.61	275
2606	S475	-8308.61	365
2607	S474	-8319.61	185
2608	S473	-8330.6	275
2609	S472	-8341.6	365
2610	S471	-8352.6	185
2611	S470	-8363.6	275
2612	S469	-8374.59	365
2613	S468	-8385.59	185
2614	S467	-8396.59	275
2615	S466	-8407.59	365
2616	S465	-8418.58	185
2617	S464	-8429.58	275
2618	S463	-8440.58	365
2619	S462	-8451.58	185
2620	S461	-8462.57	275
2621	S460	-8473.57	365
2622	S459	-8484.57	185
2623	S458	-8495.57	275
2624	S457	-8506.56	365
2625	S456	-8517.56	185
2626	S455	-8528.56	275
2627	S454	-8539.56	365
2628	S453	-8550.55	185
2629	S452	-8561.55	275
2630	S451	-8572.55	365
2631	S450	-8583.55	185
2632	S449	-8594.54	275
2633	S448	-8605.54	365
2634	S447	-8616.54	185
2635	S446	-8627.54	275
2636	S445	-8638.53	365
2637	S444	-8649.53	185
2638	S443	-8660.53	275
2639	S442	-8671.53	365
2640	S441	-8682.52	185
2641	S440	-8693.52	275
2642	S439	-8704.52	365
2643	S438	-8715.52	185
2644	S437	-8726.51	275
2645	S436	-8737.51	365
2646	S435	-8748.51	185
2647	S434	-8759.51	275
2648	S433	-8770.5	365
2649	S432	-8781.5	185
2650	S431	-8792.5	275
2651	S430	-8803.5	365
2652	S429	-8814.49	185
2653	S428	-8825.49	275
2654	S427	-8836.49	365
2655	S426	-8847.49	185
2656	S425	-8858.48	275
2657	S424	-8869.48	365
2658	S423	-8880.48	185
2659	S422	-8891.48	275
2660	S421	-8902.47	365
2661	S420	-8913.47	185
2662	S419	-8924.47	275
2663	S418	-8935.47	365
2664	S417	-8946.46	185
2665	S416	-8957.46	275
2666	S415	-8968.46	365
2667	S414	-8979.46	185
2668	S413	-8990.45	275
2669	S412	-9001.45	365
2670	S411	-9012.45	185
2671	S410	-9023.45	275
2672	S409	-9034.44	365
2673	S408	-9045.44	185
2674	S407	-9056.44	275
2675	S406	-9067.44	365
2676	S405	-9078.43	185
2677	S404	-9089.43	275
2678	S403	-9100.43	365
2679	S402	-9111.43	185
2680	S401	-9122.42	275
2681	S400	-9133.42	365
2682	S399	-9144.42	185
2683	S398	-9155.42	275
2684	S397	-9166.41	365
2685	S396	-9177.41	185</

No.	Name	X	Y
2801	S280	-10453.12	365
2802	S279	-10464.12	185
2803	S278	-10475.12	275
2804	S277	-10486.11	365
2805	S276	-10497.11	185
2806	S275	-10508.11	275
2807	S274	-10519.11	365
2808	S273	-10530.1	185
2809	S272	-10541.1	275
2810	S271	-10552.1	365
2811	S270	-10563.1	185
2812	S269	-10574.09	275
2813	S268	-10585.09	365
2814	S267	-10596.09	185
2815	S266	-10607.09	275
2816	S265	-10618.08	365
2817	S264	-10629.08	185
2818	S263	-10640.08	275
2819	S262	-10651.08	365
2820	S261	-10662.07	185
2821	S260	-10673.07	275
2822	S259	-10684.07	365
2823	S258	-10695.07	185
2824	S257	-10706.06	275
2825	S256	-10717.06	365
2826	S255	-10728.06	185
2827	S254	-10739.06	275
2828	S253	-10750.05	365
2829	S252	-10761.05	185
2830	S251	-10772.05	275
2831	S250	-10783.05	365
2832	S249	-10794.04	185
2833	S248	-10805.04	275
2834	S247	-10816.04	365
2835	S246	-10827.04	185
2836	S245	-10838.03	275
2837	S244	-10849.03	365
2838	S243	-10860.03	185
2839	S242	-10871.03	275
2840	S241	-10882.02	365
2841	S240	-10893.02	185
2842	S239	-10904.02	275
2843	S238	-10915.02	365
2844	S237	-10926.01	185
2845	S236	-10937.01	275
2846	S235	-10948.01	365
2847	S234	-10959.01	185
2848	S233	-10970	275
2849	S232	-10981	365
2850	S231	-10992	185
2851	S230	-11003	275
2852	S229	-11013.99	365
2853	S228	-11024.99	185
2854	S227	-11035.99	275
2855	S226	-11046.99	365
2856	S225	-11057.98	185
2857	S224	-11068.98	275
2858	S223	-11079.98	365
2859	S222	-11090.98	185
2860	S221	-11101.97	275
2861	S220	-11112.97	365
2862	S219	-11123.97	185
2863	S218	-11134.97	275
2864	S217	-11145.96	365
2865	S216	-11156.96	185
2866	S215	-11167.96	275
2867	S214	-11178.96	365
2868	S213	-11189.95	185
2869	S212	-11200.95	275
2870	S211	-11211.95	365
2871	S210	-11222.95	185
2872	S209	-11233.94	275
2873	S208	-11244.94	365
2874	S207	-11255.94	185
2875	S206	-11266.94	275
2876	S205	-11277.93	365
2877	S204	-11288.93	185
2878	S203	-11299.93	275
2879	S202	-11310.93	365
2880	S201	-11321.92	185
2881	S200	-11332.92	275
2882	S199	-11343.92	365
2883	S198	-11354.92	185
2884	S197	-11365.91	275
2885	S196	-11376.91	365
2886	S195	-11387.91	185
2887	S194	-11398.91	275
2888	S193	-11409.9	365
2889	S192	-11420.9	185
2890	S191	-11431.9	275
2891	S190	-11442.9	365
2892	S189	-11453.89	185
2893	S188	-11464.89	275
2894	S187	-11475.89	365
2895	S186	-11486.89	185
2896	S185	-11497.88	275
2897	S184	-11508.88	365
2898	S183	-11519.88	185
2899	S182	-11530.88	275
2900	S181	-11541.87	365

No.	Name	X	Y
2901	S180	-11552.87	185
2902	S179	-11563.87	275
2903	S178	-11574.87	365
2904	S177	-11585.86	185
2905	S176	-11596.86	275
2906	S175	-11607.86	365
2907	S174	-11618.86	185
2908	S173	-11629.85	275
2909	S172	-11640.85	365
2910	S171	-11651.85	185
2911	S170	-11662.85	275
2912	S169	-11673.84	365
2913	S168	-11684.84	185
2914	S167	-11695.84	275
2915	S166	-11706.84	365
2916	S165	-11717.83	185
2917	S164	-11728.83	275
2918	S163	-11739.83	365
2919	S162	-11750.83	185
2920	S161	-11761.82	275
2921	S160	-11772.82	365
2922	S159	-11783.82	185
2923	S158	-11794.82	275
2924	S157	-11805.81	365
2925	S156	-11816.81	185
2926	S155	-11827.81	275
2927	S154	-11838.81	365
2928	S153	-11849.8	185
2929	S152	-11860.8	275
2930	S151	-11871.8	365
2931	S150	-11882.8	185
2932	S149	-11893.79	275
2933	S148	-11904.79	365
2934	S147	-11915.79	185
2935	S146	-11926.79	275
2936	S145	-11937.78	365
2937	S144	-11948.78	185
2938	S143	-11959.78	275
2939	S142	-11970.78	365
2940	S141	-11981.77	185
2941	S140	-11992.77	275
2942	S139	-12003.77	365
2943	S138	-12014.77	185
2944	S137	-12025.76	275
2945	S136	-12036.76	365
2946	S135	-12047.76	185
2947	S134	-12058.76	275
2948	S133	-12069.75	365
2949	S132	-12080.75	185
2950	S131	-12091.75	275
2951	S130	-12102.75	365
2952	S129	-12113.74	185
2953	S128	-12124.74	275
2954	S127	-12135.74	365
2955	S126	-12146.74	185
2956	S125	-12157.73	275
2957	S124	-12168.73	365
2958	S123	-12179.73	185
2959	S122	-12190.73	275
2960	S121	-12201.72	365
2961	S120	-12212.72	185
2962	S119	-12223.72	275
2963	S118	-12234.72	365
2964	S117	-12245.71	185
2965	S116	-12256.71	275
2966	S115	-12267.71	365
2967	S114	-12278.71	185
2968	S113	-12289.7	275
2969	S112	-12300.7	365
2970	S111	-12311.7	185
2971	S110	-12322.7	275
2972	S109	-12333.69	365
2973	S108	-12344.69	185
2974	S107	-12355.69	275
2975	S106	-12366.69	365
2976	S105	-12377.68	185
2977	S104	-12388.68	275
2978	S103	-12399.68	365
2979	S102	-12410.68	185
2980	S101	-12421.67	275
2981	S100	-12432.67	365
2982	S99	-12443.67	185
2983	S98	-12454.67	275
2984	S97	-12465.66	365
2985	S96	-12476.66	185
2986	S95	-12487.66	275
2987	S94	-12498.66	365
2988	S93	-12509.65	185
2989	S92	-12520.65	275
2990	S91	-12531.65	365
2991	S90	-12542.65	185
2992	S89	-12553.64	275
2993	S88	-12564.64	365
2994	S87	-12575.64	185
2995	S86	-12586.64	275
2996	S85	-12597.63	365
2997	S84	-12608.63	185
2998	S83	-12619.63	275
2999	S82	-12630.63	365
3000	S81	-12641.62	185

No.	Name	X	Y
3001	S80	-12652.62	275
3002	S79	-12663.62	365
3003	S78	-12674.62	185
3004	S77	-12685.61	275
3005	S76	-12696.61	365
3006	S75	-12707.61	185
3007	S74	-12718.61	275
3008	S73	-12729.6	365
3009	S72	-12740.6	185
3010	S71	-12751.6	275
3011	S70	-12762.6	365
3012	S69	-12773.59	185
3013	S68	-12784.59	275
3014	S67	-12795.59	365
3015	S66	-12806.59	185
3016	S65	-12817.58	275
3017	S64	-12828.58	365
3018	S63	-12839.58	185
3019	S62	-12850.58	275
3020	S61	-12861.57	365
3021	S60	-12872.57	185
3022	S59	-12883.57	275
3023	S58	-12894.57	365
3024	S57	-12905.56	185
3025	S56	-12916.56	275
3026	S55	-12927.56	365
3027	S54	-12938.56	185
3028	S53	-12949.55	275
3029	S52	-12960.55	365
3030	S51	-12971.55	185
3031	S50	-12982.55	275
3032	S49	-12993.54	365
3033	S48	-13004.54	185
3034	S47	-13015.54	275
3035	S46	-13026.54	365
3036	S45	-13037.53	185
3037	S44	-13048.53	275
3038	S43	-13059.53	365
3039	S42	-13070.53	185
3040	S41	-13081.52	275
3041	S40	-13092.52	365
3042	S39	-13103.52	185
3043	S38	-13114.52	275
3044	S37	-13125.51	365
3045	S36	-13136.51	185
3046	S35	-13147.51	275
3047	S34	-13158.51	365
3048	S33	-13169.5	185
3049	S32	-13180.5	275
3050	S31	-13191.5	365
3051	S30	-13202.5	185
3052	S29	-13213.49	275
3053	S28	-13224.49	365
3054	S27	-13235.49	185
3055	S26	-13246.49	275
3056	S25	-13257.48	365
3057	S24	-13268.48	185
3058	S23	-13279.48	275
3059	S22	-13290.48	365
3060	S21	-13301.47	185
3061	S20	-13312.47	275
3062	S19	-13323.47	365
3063	S18	-13334.47	185
3064	S17	-13345.46	275
3065	S16	-13356.46	365
3066	S15	-13367.46	185
3067	S14	-13378.46	275
3068	S13	-13389.45	365
3069	S12	-13400.45	185
3070	S11	-13411.45	275
3071	S10	-13422.45	365
3072	S9	-13433.44	185
3073	S8	-13444.44	275
3074	S7	-13455.44	365
3075	S6	-13466.44	185
3076	S5	-13477.43	275
3077	S4	-13488.43	365
3078	S3	-13499.43	185
3079	S2	-13510.43	275
3080	S1	-13521.42	365
3081	SDUM1	-13532.42	185
3082	SDUM0		

4. System Interface

4.1. DSI System Interface

4.1.1. General Description

The pad mapping of MIPI DSI interface is set by IM[2:0] pin, LANSEL pins and MIPI_LANE_SEL register(as below table).

Table 2: DSI Interface Lane Mode Selection

External Pad Set				Register	Configuration of MIPI Lane				
LANSEL	IM2	IM1	IM0	Page4_R00h MIPI_LANE_SEL	D0P/N Pin	D1P/N Pin	CLKP/N Pin	D2P/N Pin	D3P/N Pin
0	0	0	0	1	D3P/N	D2P/N	CLKP/N	D1P/N	D0P/N
0	0	0	1	1	D3N/P	D2N/P	CLKN/P	D1N/P	D0N/P
0	0	1	0	1	D0P/N	D1P/N	CLKP/N	D2P/N	D3P/N
0	0	1	1	1	D0N/P	D1N/P	CLKN/P	D2N/P	D3N/P
0	1	0	0	1	D3P/N	D0P/N	CLKP/N	D1P/N	D2P/N
0	1	0	1	1	D3N/P	D0N/P	CLKN/P	D1N/P	D2N/P
0	1	1	0	1	D2P/N	D1P/N	CLKP/N	D0P/N	D3P/N
0	1	1	1	1	D2N/P	D1N/P	CLKN/P	D0N/P	D3N/P
1	0	0	0	1	-	-	CLKP/N	D1P/N	D0P/N
1	0	0	1	1	-	-	CLKN/P	D1N/P	D0N/P
1	0	1	0	1	D0P/N	D1P/N	CLKP/N	-	-
1	0	1	1	1	D0N/P	D1N/P	CLKN/P	-	-
1	1	0	0	1	-	D0P/N	CLKP/N	D1P/N	-
1	1	0	1	1	-	D0N/P	CLKN/P	D1N/P	-
1	1	1	0	1	-	D1P/N	CLKP/N	D0P/N	-
1	1	1	1	1	-	D1N/P	CLKN/P	D0N/P	-
0	0	0	0	0	-	D2P/N	CLKP/N	D1P/N	D0P/N
0	0	0	1	0	-	D2N/P	CLKN/P	D1N/P	D0N/P
0	0	1	0	0	D0P/N	D1P/N	CLKP/N	D2P/N	-
0	0	1	1	0	D0N/P	D1N/P	CLKN/P	D2N/P	-
0	1	0	0	0	-	D0P/N	CLKP/N	D1P/N	D2P/N
0	1	0	1	0	-	D0N/P	CLKN/P	D1N/P	D2N/P
0	1	1	0	0	D2P/N	D1P/N	CLKP/N	D0P/N	-
0	1	1	1	0	D2N/P	D1N/P	CLKN/P	D0N/P	-
Others					Reserved				

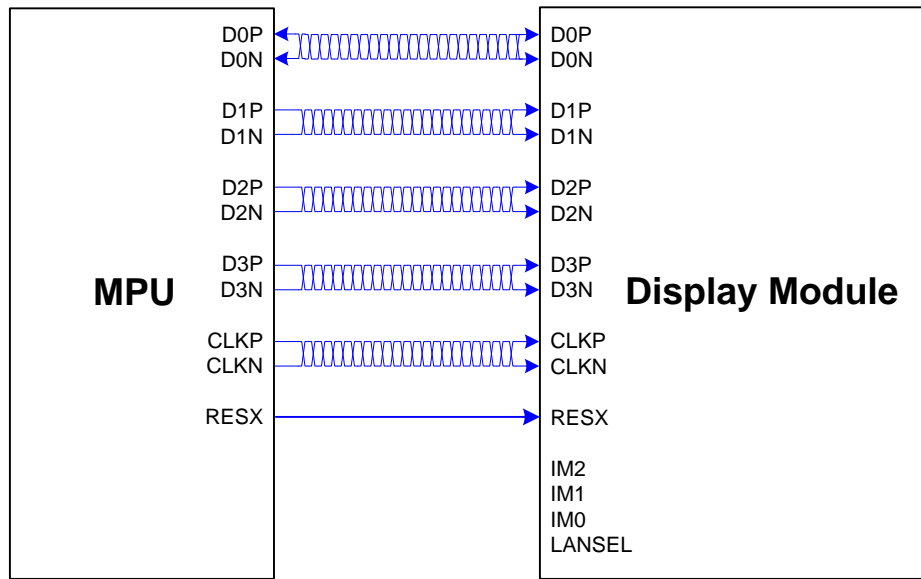

Figure 2: DSI System Interface Diagram

The communication is separated into two different levels between the MCU and the display module:

- ❖ Low level communication is done on the interface level.
- ❖ High level communication is done on the packet level.

4.1.2. Interface Level Communication

4.1.2.1. General

The display module uses data and clock lane differential pairs for DSI (DSI-2M). Both differential lane pairs can be driven to Low Power (LP) or High Speed (HS) mode.

Low Power mode means that each line of the differential pair is used in the single ended mode, a differential receiver is disable (a termination resistor of the receiver is disable), and it can be driven into a low power mode.

High Speed mode means that differential pairs (the termination resistor of the receiver is enable) are not used in the single ended mode.

Different modes and protocols are used in each mode when transferring information from the MCU to the display module and vice versa.

The State Codes of the High Speed (HS) and Low Power (LP) lane pair are defined below.

Table 3: High Speed and Low-Power Lane Pair State Codes

Lane Pair State Code	Line DC Voltage Levels		High Speed (HS)	Low Power	
	DATA_P	DATA_N	Burst Mode	Control Mode	Escape Mode
HS-0	Low (HS)	High (HS)	Differential – 0	Note 1	Note1
HS-1	High (HS)	Low (HS)	Differential – 1	Note 1	Note 1
LP-00	Low (LP)	Low (LP)	Not Defined	Bridge	Space
LP-01	Low (LP)	High (LP)	Not Defined	HS – Request	Mark - 0
LP-10	High (LP)	Low (LP)	Not Defined	LP - Request	Mark - 1
LP-11	High (LP)	High (LP)	Not Defined	Stop	Note 2

Notes:

1. Low-Power Receivers (LP-Rx) of the lane pair will check the LP-00 state code when the Lane Pair is in the High Speed (HS) mode.
2. If Low-Power Receivers (LP-Rx) of the lane pair recognizes the LP-11 state code, then the lane pair will return to LP-11 of the Control Mode.
3. $n = 0, 1, 2$ and 3 (D1P/N, D2 P/N and D3 P/N lanes only for HS-0 and HS-1)

4.1.2.2. DSI CLK Lanes

CLKP/N lanes can be driven into three different power modes: Low Power Mode (LPM), Ultra-Low Power Mode (ULPM) and High Speed Clock Mode (HSCM). Clock lane are in the single ended mode (LP = Low Power) when entering or leaving Low Power Mode (LPM) or Ultra-Low Power Mode (ULPM). Clock lane is in the single ended mode (LP = Low Power) when entering in or leaving High Speed Clock Mode (HSCM). These entering and leaving protocols use Clock lane in the single ended mode to generate an entering or leaving sequence. The principal flow chart of the different Clock lane power modes is illustrated below.

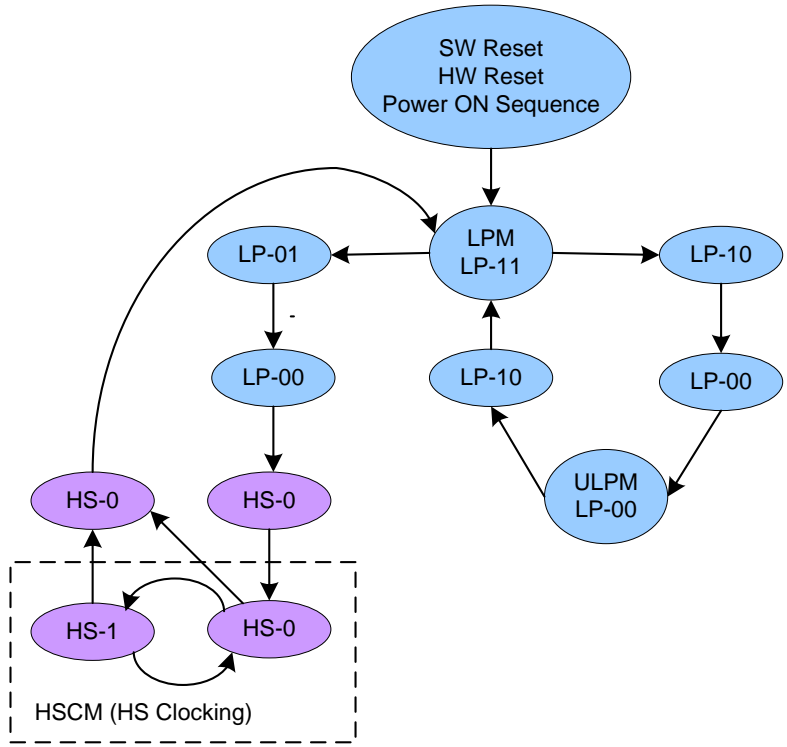

Figure 3: Clock lane Power Modes

4.1.2.2.1. Low Power Mode (LPM)

CLKP/N lanes can be driven to the Low Power Mode (LPM), when CLKP/N lanes enter LP-11 State Code, in three different ways:

- 1) After SW Reset, HW Reset or Power On Sequence => LP-11
- 2) After CLKP/N lanes leave Ultra-Low Power Mode (ULPM, LP-00 State Code) => LP-10 => LP-11 (LPM).

This sequence is illustrated below.

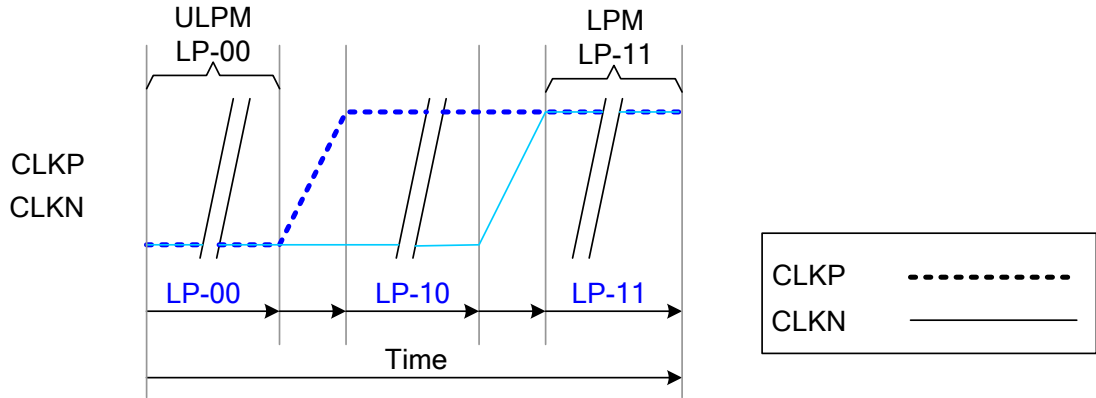

Figure 4: From ULPM to LPM

3) After CLKP/N lanes leave High Speed Clock Mode (HSCM, HS-0 or HS-1 State Code) => HS-0=> LP-11 (LPM).

This sequence is illustrated below.

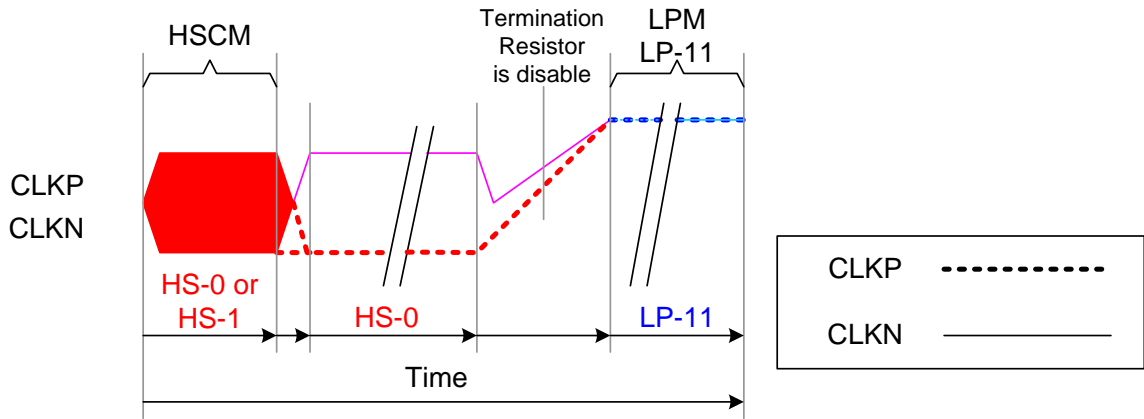

Figure 5: From High Speed Clock Mode (HSCM) to LPM

The changes of all the three modes are illustrated in the flow chart below.

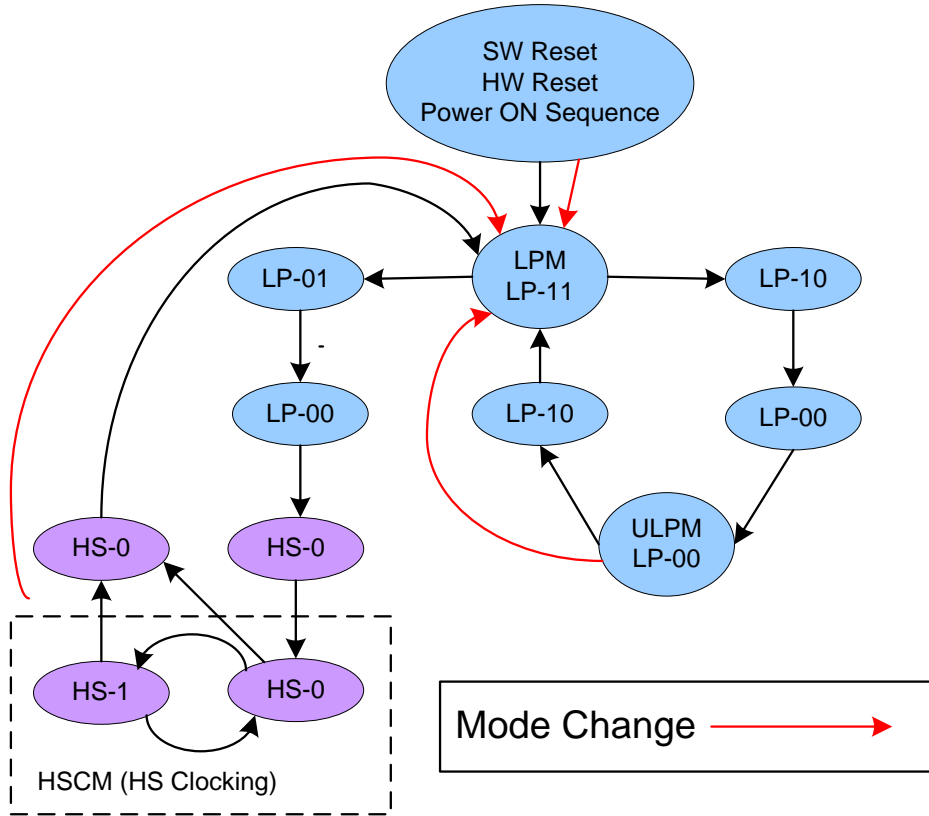

Figure 6: All Three Mode Changes to LPM

4.1.2.2.2. Ultra-Low Power Mode (ULPM)

CLKP/N lanes can be driven to the Ultra-Low power Mode (ULPM) when CLK lanes enter the LP-00 State Code. The only entering possibility is from the Low Power Mode (LPM, LP-11 State Code) => LP-10 => LP-00 (ULPM). This sequence is illustrated below.

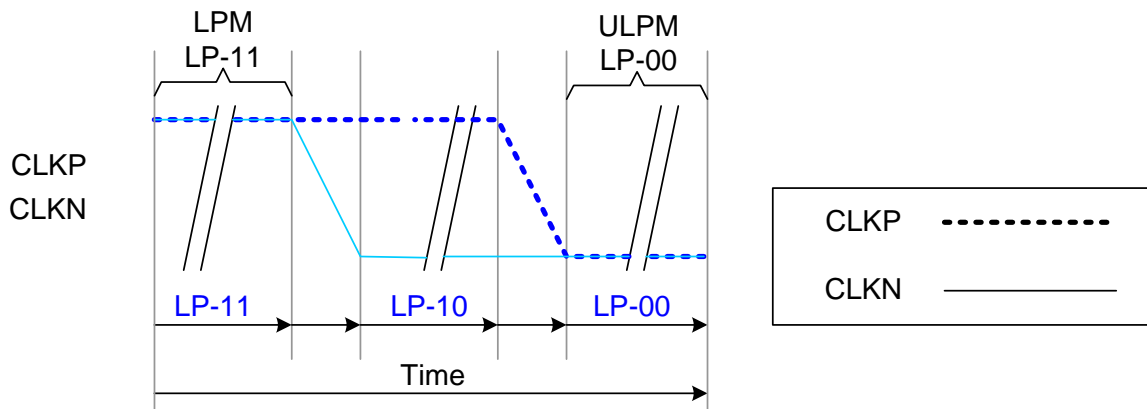

Figure 7: From LPM to ULPM

The mode change is also illustrated below.

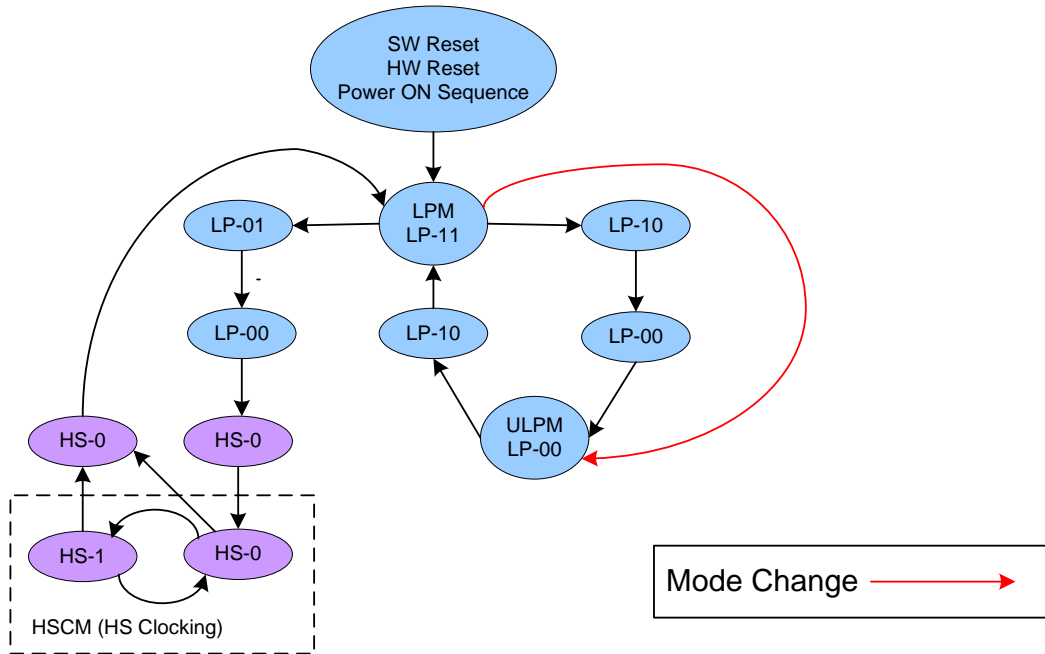

Figure 8: Mode Change from LPM to ULPM

4.1.2.2.3. High-Speed Clock Mode (HSCM)

CLKP/N lanes can be driven to the High Speed Clock Mode (HSCM) when CLK lanes start to function between HS-0 and HS-1 State Codes. The only entering possibility is from the Low Power Mode (LPM, LP-11 State Code) => LP-01 => LP-00 => HS-0 => HS-0/1 (HSCM). This sequence is illustrated below.

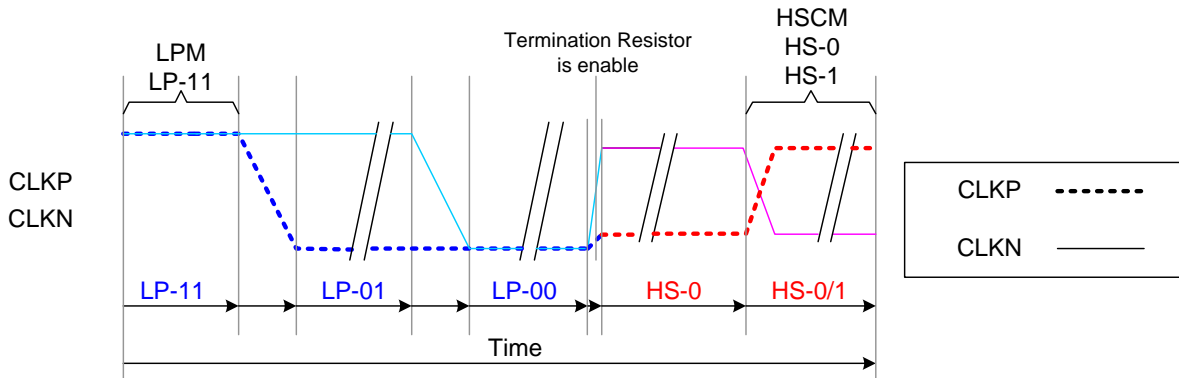

Figure 9: From LPM to HSCM

The mode change is also illustrated below.

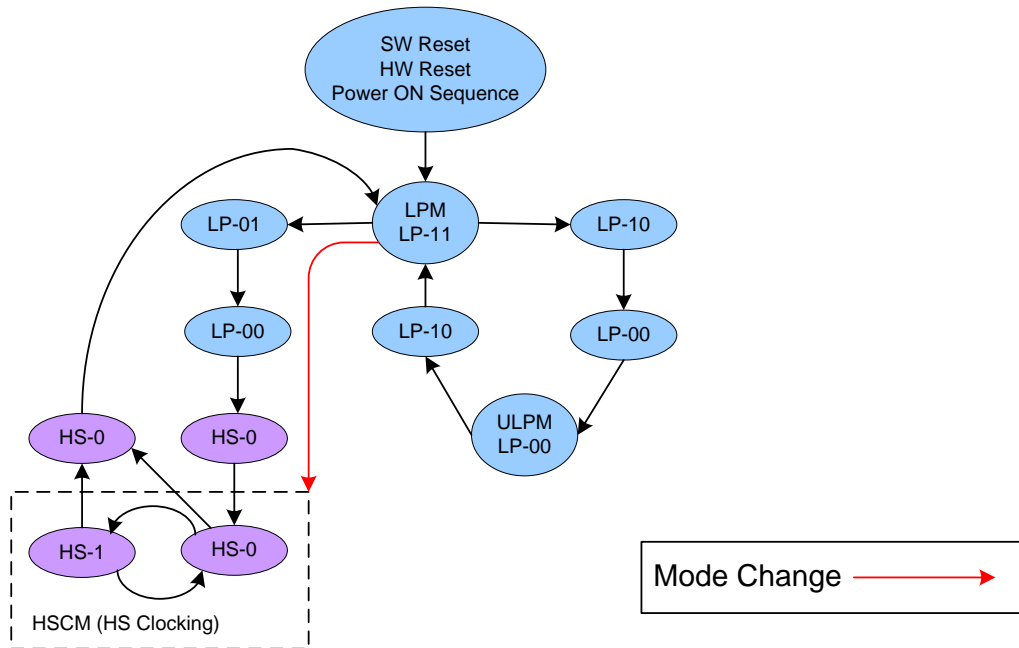

Figure 10: Mode Change from LPM to HSCM

The high speed clock (CLKP/N) starts before high speed data is sent via data lanes. The high speed clock continues clocking after the high speed data sending is stopped.

The burst of the high speed clock consists of:

- Even number of transitions
- Start state is HS-0
- End state is HS-0

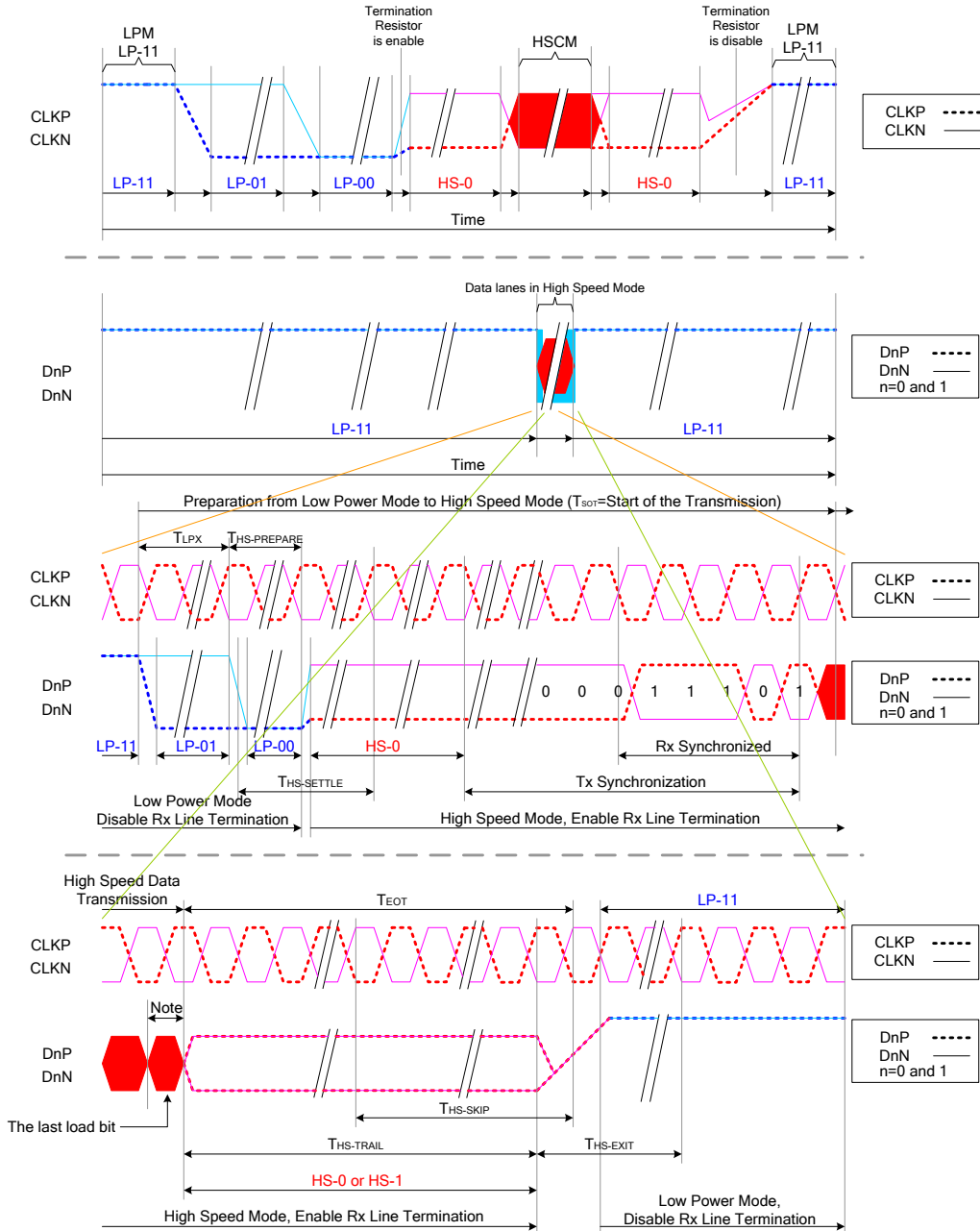

Figure 11: High Speed Clock Burst

Notes:

1. If the last load bit is HS-0, the transmitter changes from HS-0 to HS-1.
2. If the last load bit is HS-1, the transmitter changes from HS-1 to HS-0.

4.1.2.3. DSI Data Lanes

4.1.2.3.1. General

D3P/N, D2P/N, D1P/N and D0P/N Data Lanes can be driven into different modes:

- Escape Mode (Only D0P/N data lane is used)
- High-Speed Data Transmission (all data lanes are used)
- Bus Turnaround Request (Only D0P/N data lane are used)

These modes and their entering codes are defined in the following table.

Table 4: Entering and Leaving Sequences

Mode	Entering Mode Sequence	Leaving Mode Sequence
Escape Mode ¹	LP-11 → LP-10 → LP-00 → LP-01 → LP-00	LP-00 → LP-10 → LP-11 (Mark-1)
High-Speed Data Transmission ²	LP-11 → LP-01 → LP-00 → HS-0	(HS-0 or HS-1) → LP-11
Bus Turnaround Request ³	LP-11 → LP-10 → LP-00 → LP-10 → LP-00	Hi-Z

4.1.2.3.2. Escape Modes

D0P/N data lanes can be used in different Escape Modes when data lanes are in the Low Power (LP) mode. These Escape Modes are used to:

- ◆ Send “Low-Power Data Transmission” (LPDT) from the MCU to the display module,
- ◆ Drive data lanes to “Ultra-Low Power State” (ULPS),
- ◆ Indicate “Remote Application Reset” (RAR), which can reset the display module,
- ◆ Indicate “Acknowledge” (ACK), which is used to transmit a non-error event from the display module to the MCU.

The basic sequence of the Escape Mode is as follows:

- Start: LP-11
- Escape Mode Entry (EME): LP-11 => LP-10 => LP-00 => LP-01 => LP-00
- Escape Command (EC), which is coded, when one of the data lanes changes from low-to-high-to-low then this changed data lane presents the value of the current data bit (D0P = 1, D0N= 0). When DSI-D0 changes from low-to-high-to-low, the receiver will latch a data bit, which value is logical 0. The receiver will use this low-to-high-to-low transition as its internal clock.
- A load if it is needed
- Exit Escape (Mark-1) LP-00 => LP-10 => LP-11
- End: LP-11

This basic construction is illustrated below:

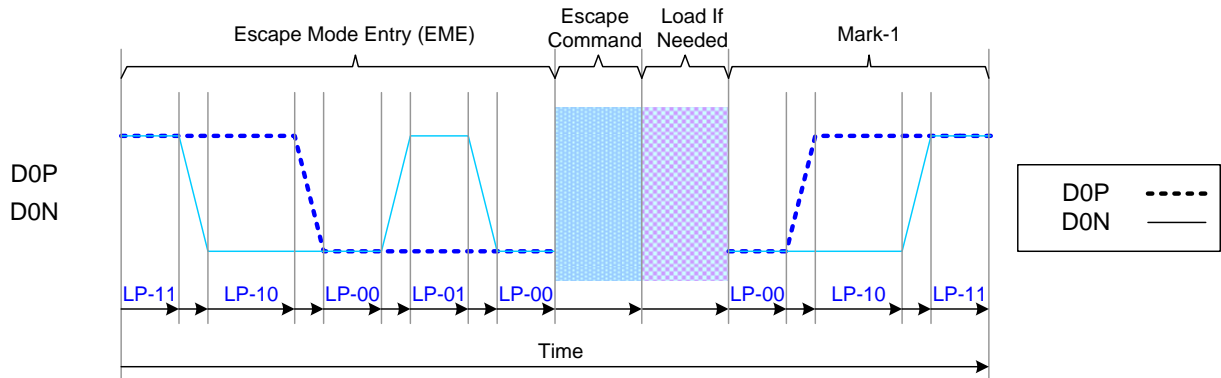

Figure 12 General Escape Mode Sequence

A total of eight Escape Commands (EC) are divided into two types: Mode and Trigger, as shown in Table 5: Escape Commands.

An example of the Mode type Escape Command is 'Ultra-Low Power Mode', where the MCU instructs the display module to enter its Ultra-Low Power Mode.

Escape commands are defined in the following table.

Table 5: Escape Commands

Escape command	Command Type Mode/Trigger	Entry command Pattern (First Bit → Last Bit Transmitted)	Dn	D0
Low-Power Data Transmission	Mode	1110 0001 b	-	X
Ultra-Low Power Mode	Mode	0001 1110 b	X	X
Undefined-1, ^{Note 1}	Mode	1001 1111 b	-	-
Undefined-2, ^{Note 1}	Mode	1101 1110 b	-	-
Remote Application Reset	Trigger	0110 0010 b	-	X
Acknowledge	Trigger	0010 0001 b	-	X
Unknown-5, ^{Note 1}	Trigger	1010 0000 b	-	-

Notes:

1. This Escape command support is not implemented on the display module.
2. n = 1
3. x = Supported
4. - = Not Supported

4.1.2.3.2.1. Low-Power Data Transmission (LPDT)

The MCU can send data to the display module in the Low-Power Data Transmission (LPDT) mode when data lanes enter the Escape Mode and Low-Power Data Transmission (LPDT) command is sent to the display module. The display module also uses the same sequence when it sends data to the MCU. The Low Power Data Transmission (LPDT) uses the following sequence:

- Start: LP-11
- Escape Mode Entry (EME): LP-11 => LP-10 => LP-00 => LP-01 => LP-00
- Low-Power Data Transmission (LPDT) command in the Escape Mode: 1110 0001 (first to last bit)
- Load (Data):
 - ✧ One or more bytes (one byte = 8 bit)
 - ✧ Data lanes are in pause mode when data lanes are stopped (both lanes are low) between bytes
- Mark-1: LP-00 => LP-10 => LP-11
- End: LP-11

This sequence is illustrated for reference purposes below:

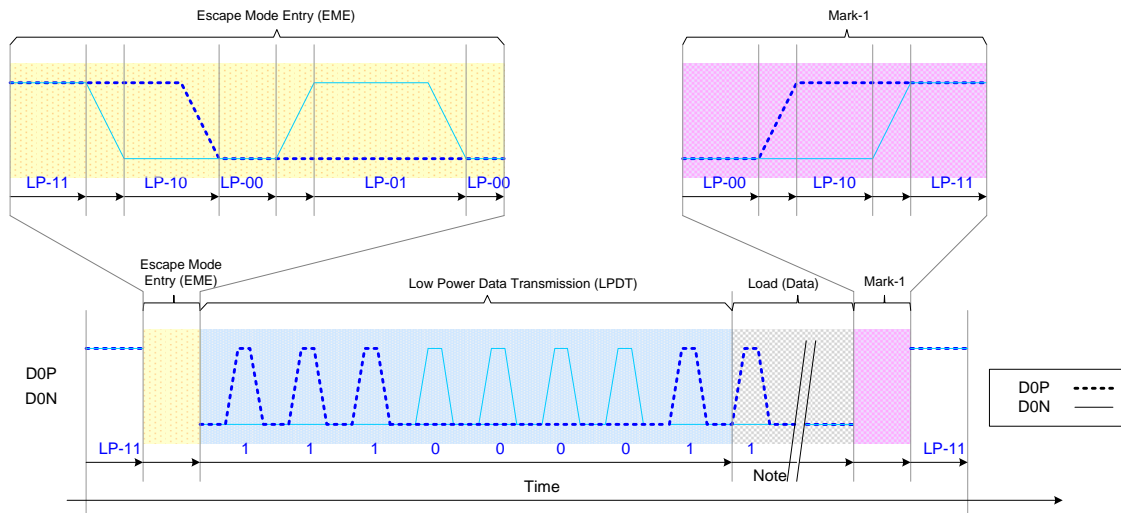

Figure 13: Low-Power Data Transmission (LPDT)

Note: Load (Data) presents that the first bit is the logical 1 in this example.

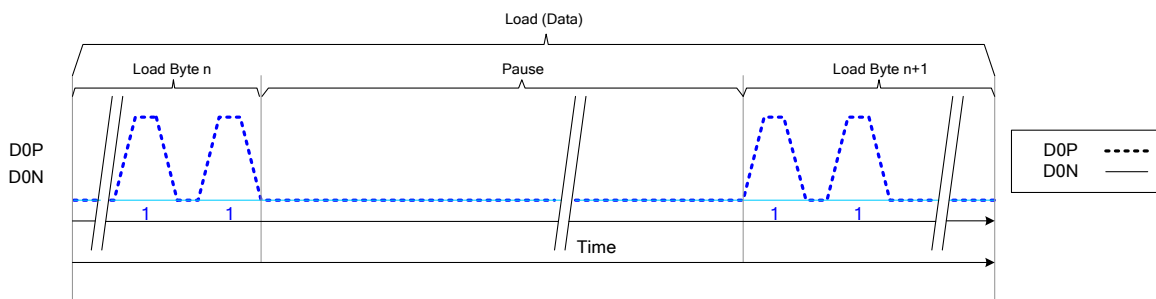

Figure 14: Pause (Example)

4.1.2.3.2.2. Ultra-Low Power State (ULPS)

The MCU can force data lanes get into the Ultra-Low Power State (ULPS) mode when data lanes enter the Escape Mode. The Ultra-Low Power State (ULPS) uses the following sequence:

- Start: LP-11
- Escape Mode Entry (EME): LP-11 => LP-10 => LP-00 => LP-01 => LP-00
- Ultra-Low Power State (ULPS) command in the Escape Mode: 0001 1110 (first to last bit)
- Ultra-Low Power State (ULPS) when the MCU keeps data lanes low
- Mark-1: LP-00 => LP-10 => LP-11
- End: LP-11 (Next command must wait 100us after data lanes leave ULPS)

This sequence is illustrated for reference purposes below:

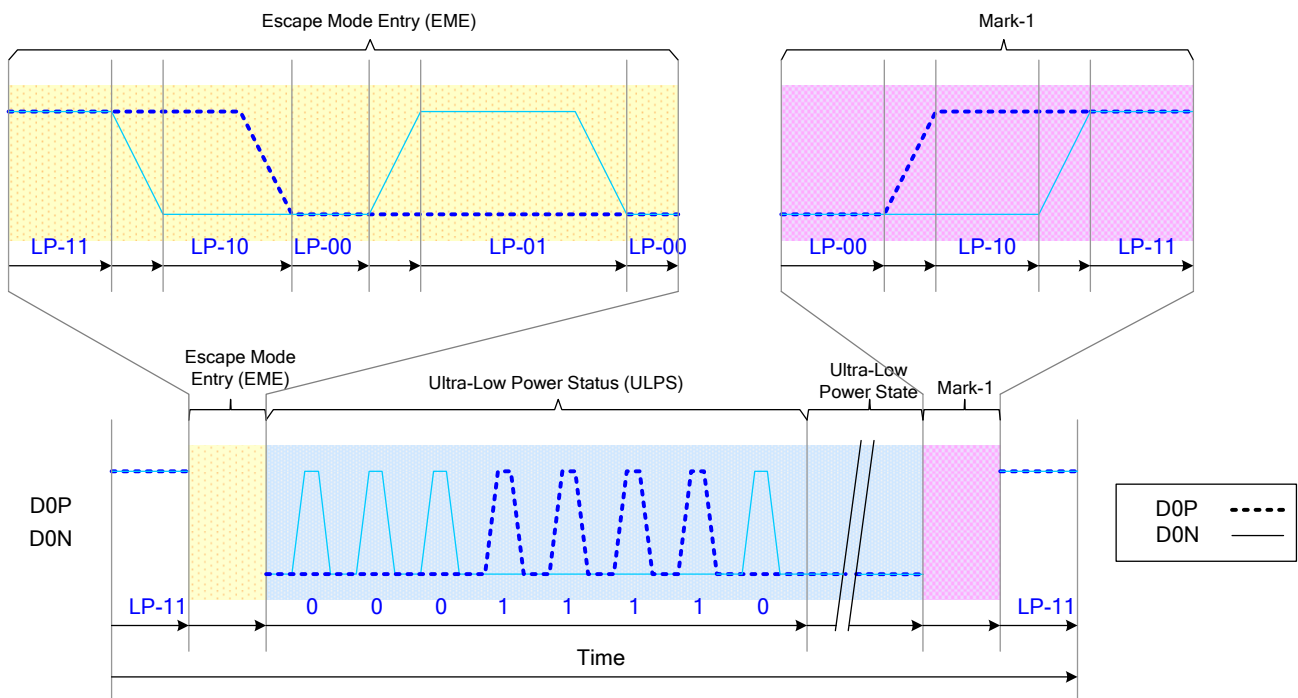

Figure 15: Ultra-Low Power State (ULPS)

4.1.2.3.2.3. Remote Application Reset (RAR)

The MCU can inform the display module that it should be reset in Remote Application Reset (RAR) trigger when data lanes enter the Escape Mode. The Remote Application Reset (RAR) uses the following sequence:

- Start: LP-11
- Escape Mode Entry (EME): LP-11 => LP-10 => LP-00 => LP-01 => LP-00
- Remote Application Reset (RAR) command in Escape Mode: 0110 0010 (first to last bit)
- Mark-1: LP-00 => LP-10 => LP-11
- End: LP-11

This sequence is illustrated for reference purposes below:

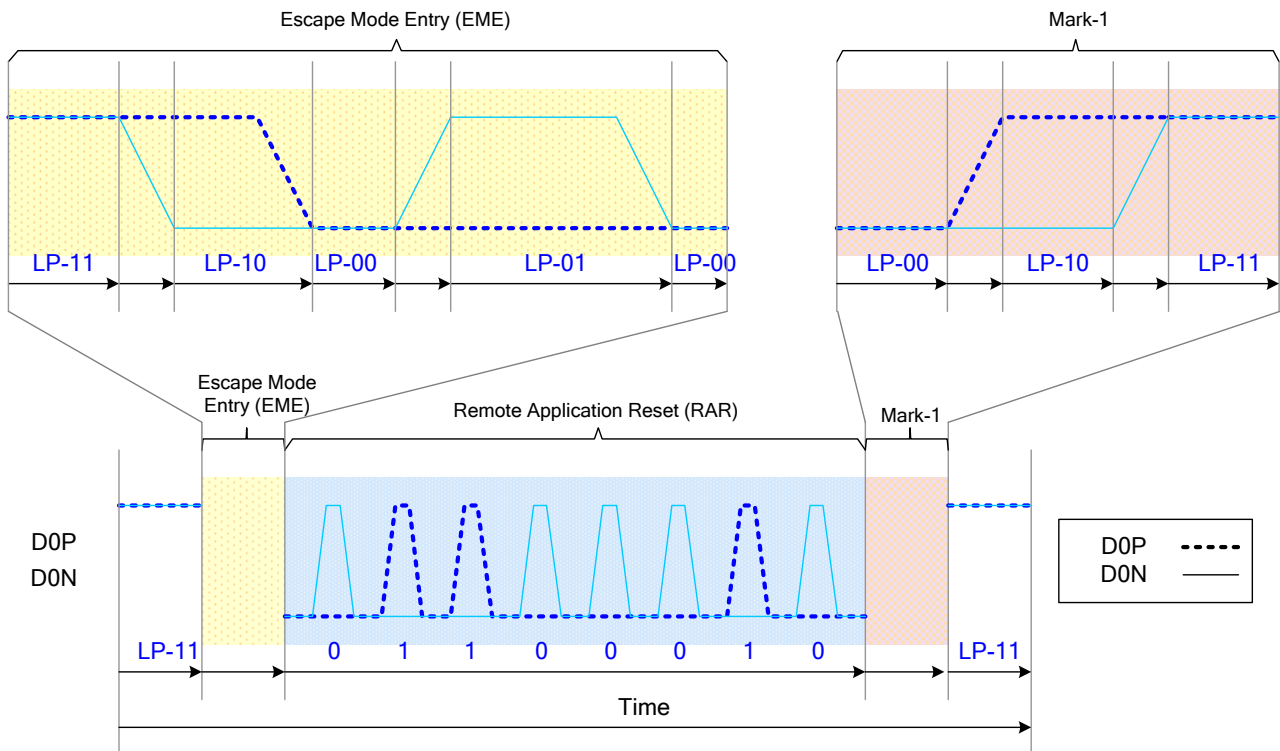

Figure 16: Remote Application Reset (RAR)

4.1.2.3.2.4. Acknowledge (ACK)

The display module can inform the MCU an error is not recognized by Acknowledge (ACK). The display module sends the Acknowledge (ACK) with the following sequence:

- Start: LP-11
- Escape Mode Entry (EME): LP-11 => LP-10 => LP-00 => LP-01 => LP-00
- Acknowledge (ACK) command in the Escape Mode: 0010 0001 (first to last bit)
- Mark-1: LP-00 => LP-10 => LP-11
- End: LP-11

This sequence is illustrated for reference purposes below:

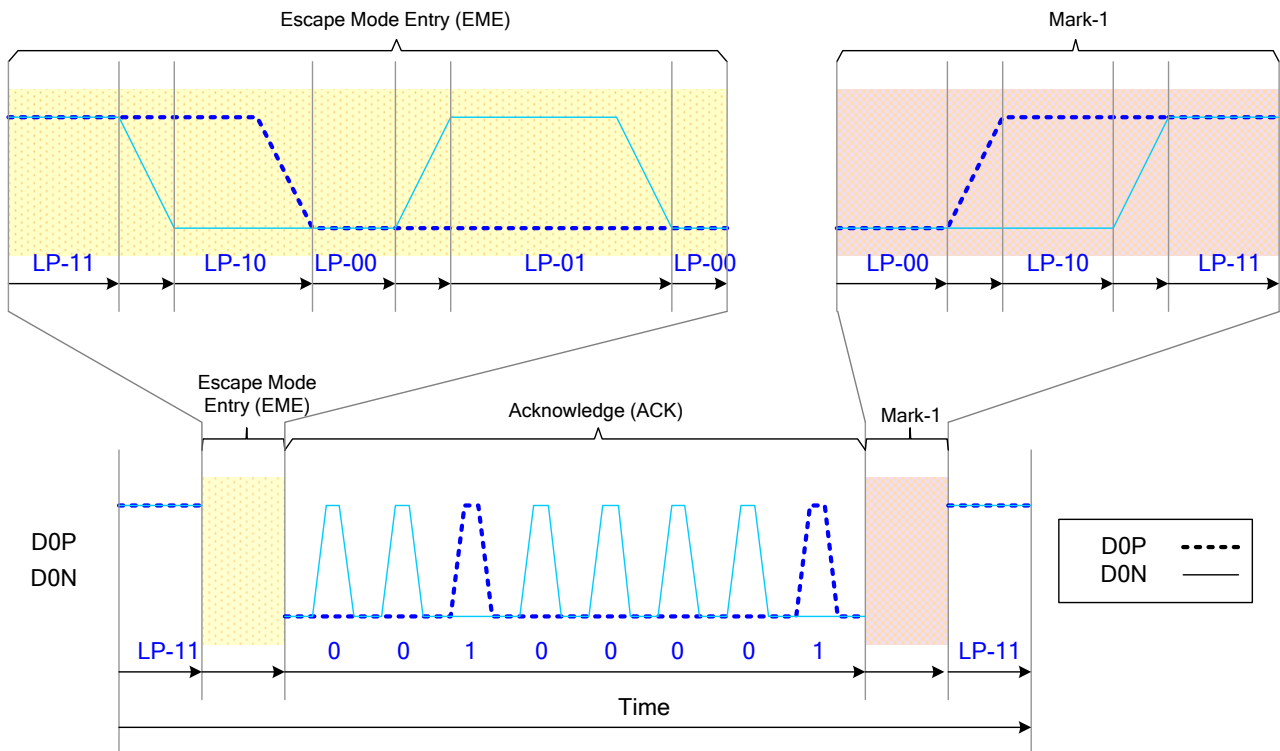

Figure 17: Acknowledge (ACK)

4.1.2.3.3. High-Speed Data Transmission (HSDT)

4.1.2.3.3.1. Entering High-Speed Data Transmission (TSOT of HSDT)

The display module enters High-Speed Data Transmission (HSDT) when Clock lane CLKP/N have already entered the High-Speed Clock Mode (HSCM) by the MCU. See more information in the section “4.1.2.2.3 High-Speed Clock Mode (HSCM)”.

Data lanes D3P/N, D2P/N, D1P/N and D0P/N of the display module enter the High-Speed Data Transmission (TSOT of HSDT) as follows:

- Start: LP-11
- HS-Request: LP-01
- HS-Settle: LP-00 => HS-0 (Rx: Lane Termination Enable)
- Rx Synchronization: 011101 (Tx (= MCU) Synchronization: 0001 1101)
- End: High-Speed Data Transmission (HSDT) – Ready to receive High-Speed Data Load

The sequence of entering High-Speed Data Transmission (TSOT of HSDT) is illustrated below:

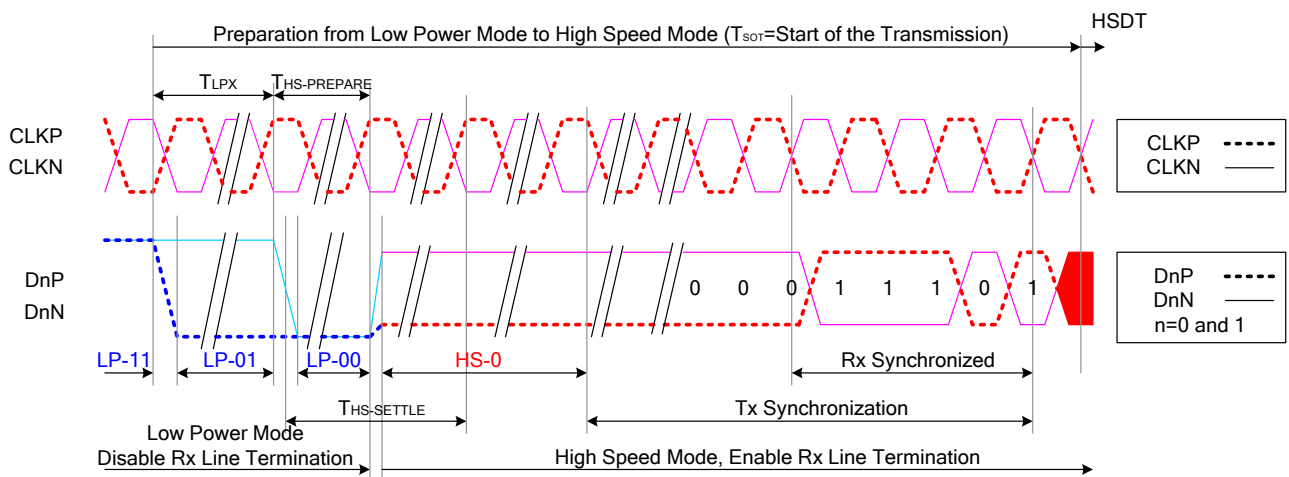

Figure 18: Entering High-Speed Data Transmission (TSOT of HSDT)

4.1.2.3.3.2. Leaving High-Speed Data Transmission (TEOT of HSDT)

The display module leaves the High-Speed Data Transmission (TEOT of HSDT) when Clock lane DSICLK+/- are in the High-Speed Clock Mode (HSCM) by the MCU, and this HSCM is kept until data lanes D3P/N, D2P/N, D1P/N and D0P/N are in the LP-11 mode. See more information in the section “4.1.2.2.3 High-Speed Clock Mode (HSCM)”. Data lanes D3P/N, D2P/N, D1P/N and D0P/N of the display module leave the High-Speed Data Transmission (TEOT of HSDT) as follows:

- Start: High-Speed Data Transmission (HSDT)
- Stops High-Speed Data Transmission
 - ◇ MCU changes to HS-1, if the last load bit is HS-0
 - ◇ MCU changes to HS-0, if the last load bit is HS-1
- End: LP-11 (Rx: Lane Termination Disable)

The sequence of leaving High-Speed Data Transmission (TEOT of HSDT) is illustrated below:

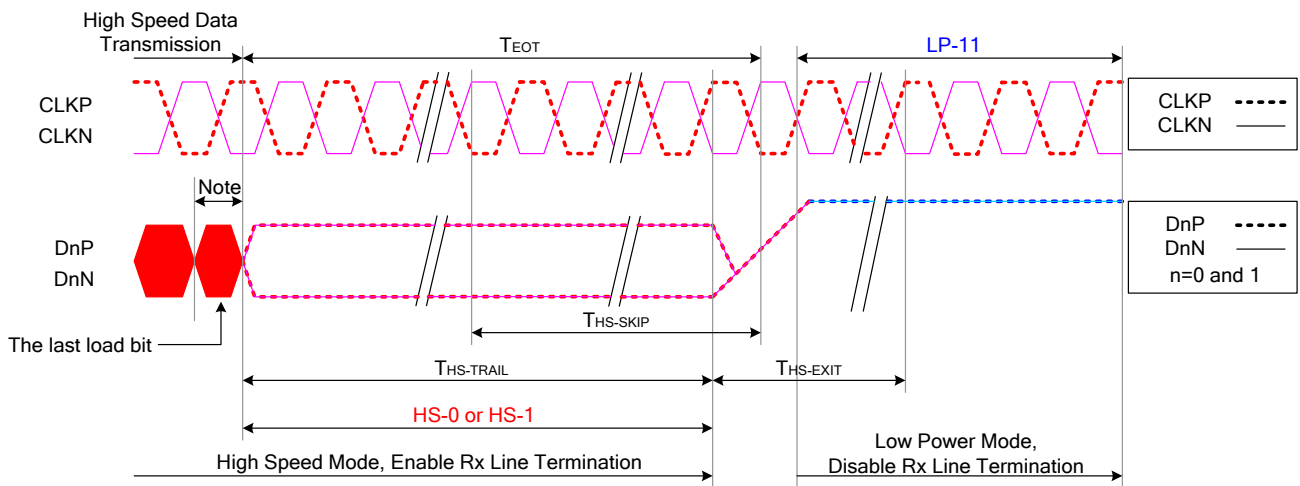

Figure 19: Leaving High-Speed Data Transmission (TEOT of HSDT)

Notes:

1. If the last load bit is HS-0, the transmitter changes from HS-0 to HS-1.
2. If the last load bit is HS-1, the transmitter changes from HS-1 to HS-0.

4.1.2.3.3.3. Burst of the High-Speed Data Transmission (HSDT)

The burst of the “High-Speed Data Transmission” (HSDT) can consist of one or several data packet(s). These data packets can be Long (LPa) or Short (SPa) packets. These packets are defined in the section “4.1.3.1 Short Packet (SPa) and Long Packet (LPa) Structures”. These different burst of the High-Speed Data Transmission (HSDT) cases are illustrated for reference purposes below.

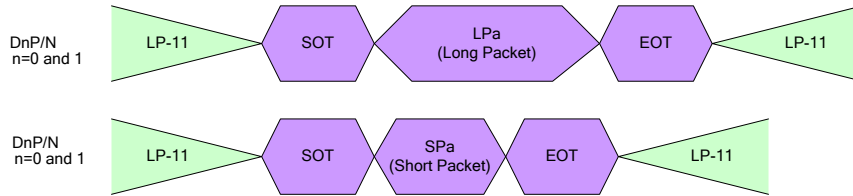

Figure 20: Single Packet in High-Speed Data Transmissions

The multiple packets in High-Speed Data Transmission are illustrated for reference purposes below:

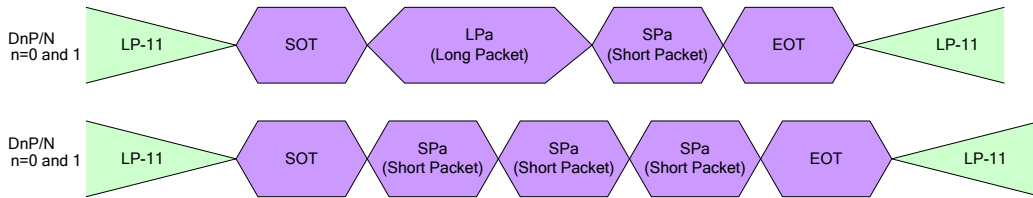

Figure 21: Multiple Packets in High-Speed Data Transmission – Examples

Table 6: Abbreviations

Abbreviation	Explanation
EOT	End of the Transmission
LPa	Long Packet
LP-11	Low Power Mode, Both of Data lanes are ‘1’s (Stop Mode)
SPa	Short Packet
SOT	Start of the Transmission

Byte orders of the sent packet in High-Speed Data Transmission (HSDT) are as follows.

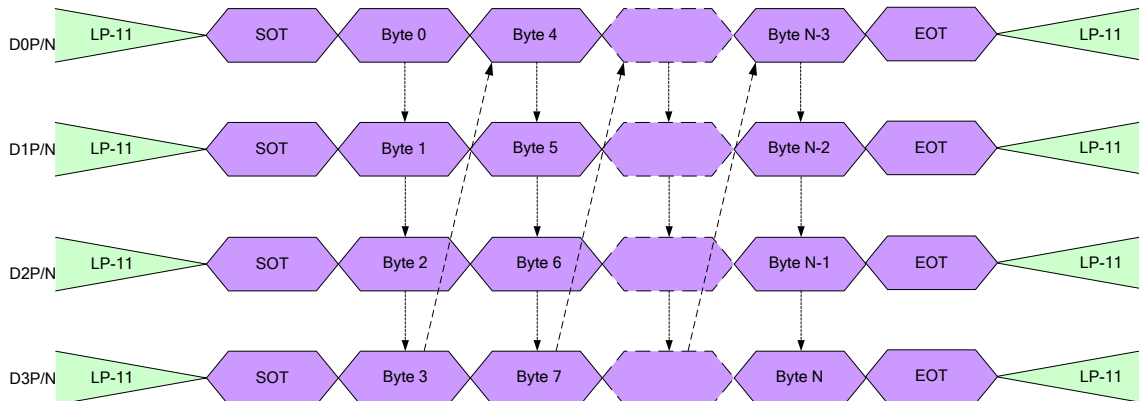

Figure 22: Number of Bytes, N, transmitted is an integer multiple of the number of lanes

The information contained herein is the exclusive property of ILI Technology Corp. and shall not be distributed, reproduced, or disclosed in whole or in part without prior written permission of ILI Technology Corp.

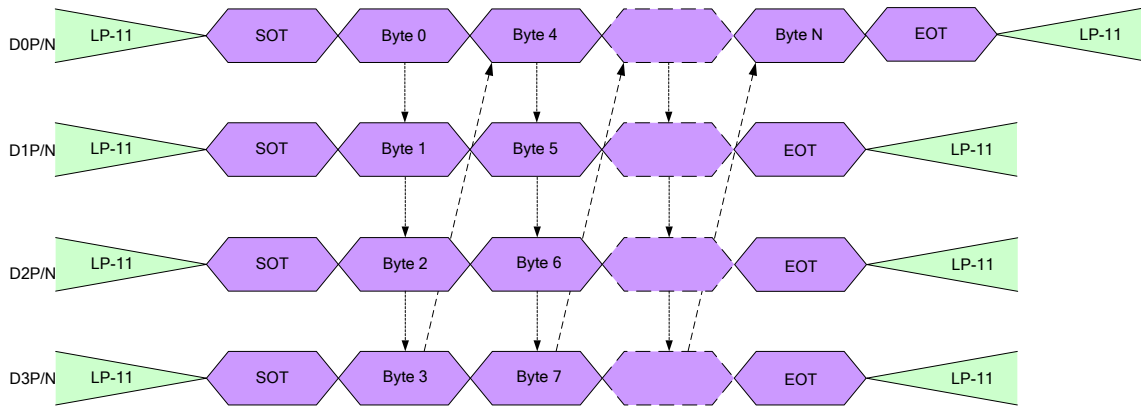

Figure 23: Number of Bytes, N, transmitted is NOT an integer multiple of the number of lanes (Example 1)

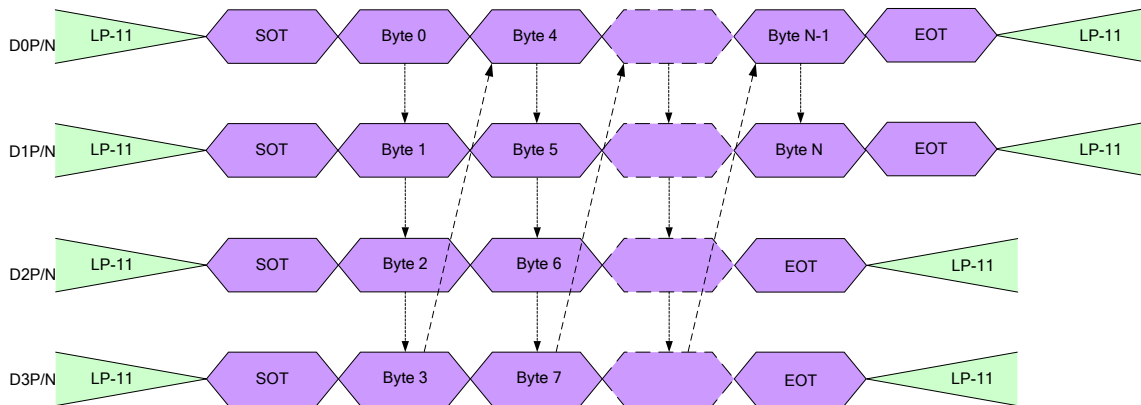

Figure 24: Number of Bytes, N, transmitted is NOT an integer multiple of the number of lanes (Example 2)

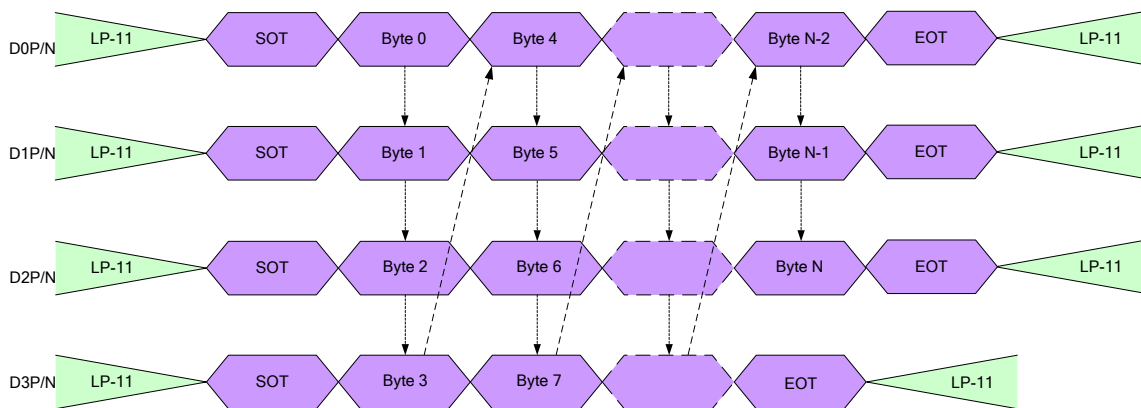

Figure 25: Number of Bytes, N, transmitted is NOT an integer multiple of the number of lanes (Example 3)

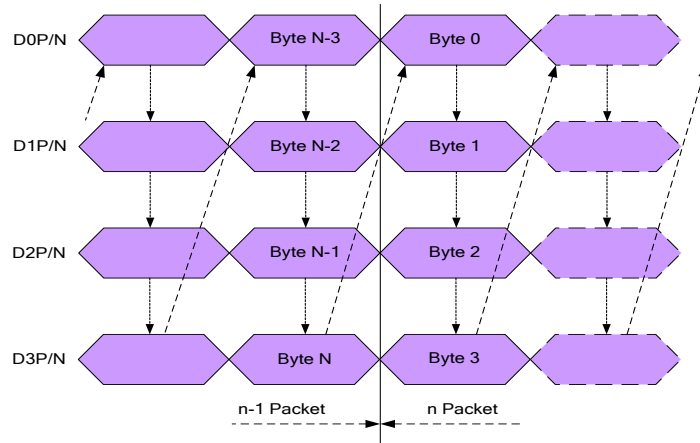

Figure 26: Continuous Multiple Packets in HSDT when Number of Bytes is Equal on Data Lanes at the End of the Packet

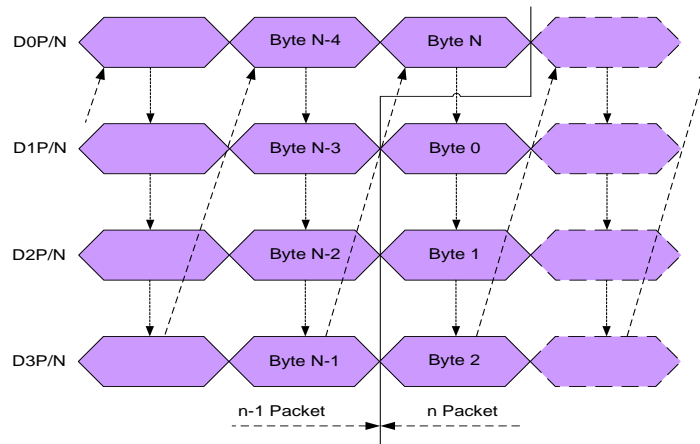

Figure 27: Continuous Multiple Packets in HSDT when Number of Bytes is not Equal on Data Lanes at the End of the Packet (Example 1)

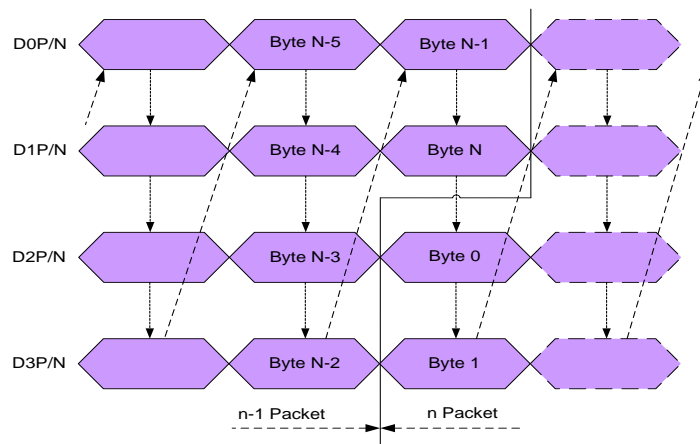

Figure 28: Continuous Multiple Packets in HSDT when Number of Bytes is not Equal on Data Lanes at the End of the Packet (Example 2)

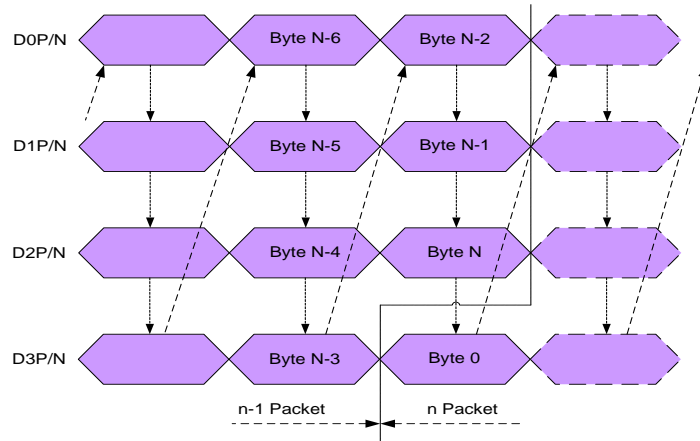

Figure 29: Continuous Multiple Packets in HSDT when Number of Bytes is not Equal on Data Lanes at the End of the Packet (Example 3)

4.1.2.3.4. Bus Turnaround (BTA)

The MCU or display module, which controls D0P/N Data Lanes, can start a bus turnaround procedure when it requires information from a receiver, which can be the MCU or display module.

The MCU and display module use the same sequence when this bus turnaround procedure is used. The sequence, when the MCU wants to do the bus turnaround procedure to the display module, is described for reference purposes as follows:

- Start (MCU): LP-11
- Turnaround Request (MCU): LP-11 => LP-10 => LP-00 => LP-10 => LP-00
- The MCU waits until the display module starts to control D0P/N data lanes and the MCU stops to control D0P/N data lanes (= High-Z)
- The display module changes to the stop mode: LP-00 => LP-10 => LP-11

The bus turnaround procedure (from the MCU to the display module) is illustrated below:

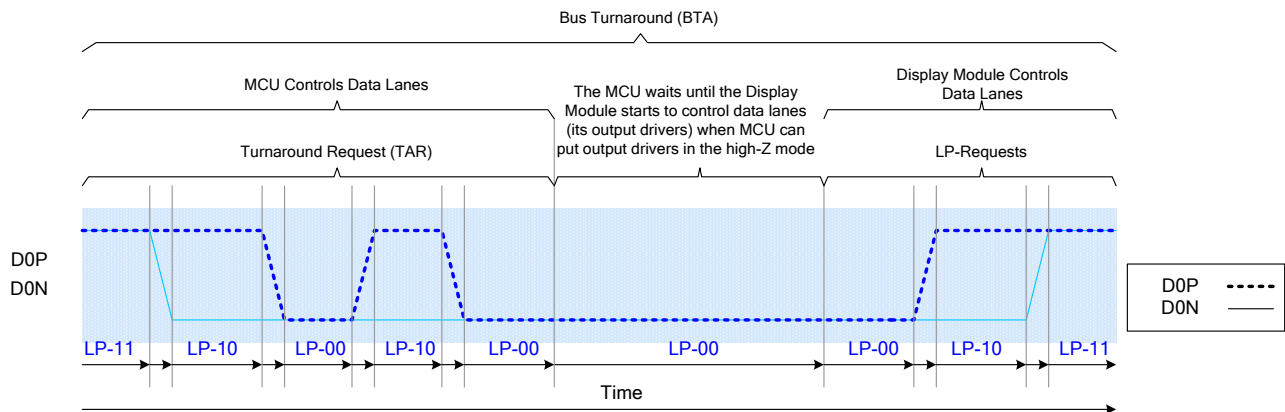

Figure 30: Bus Turnaround Procedure

MCU and display module terms can be switched in Figure 30 if the Bus Turnaround (BTA) is from the display module to the MCU.

4.1.3. Packet Level Communication

4.1.3.1. Short Packet (SPa) and Long Packet (LPa) Structures

Short Packet (SPa) and Long Packet (LPa) are always used when data transmission is done in Low Power Data Transmission (LPDT) or High-Speed Data Transmission (HSDT) modes. The lengths of the packets are:

- ❖ Short Packet (SPa): 4 bytes
- ❖ Long Packet (LPa): 6 to 65,541 bytes

The type (SPa or LPa) of the packet can be recognized from their package headers (PH).

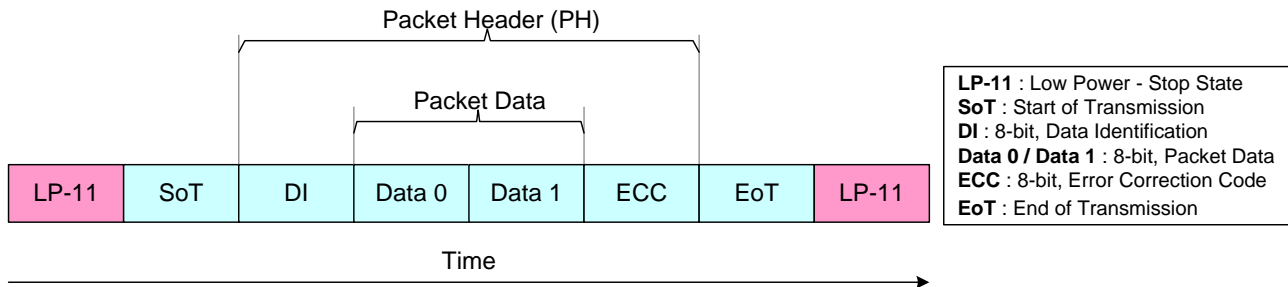

Figure 31: Short Packet (SPa) Structure

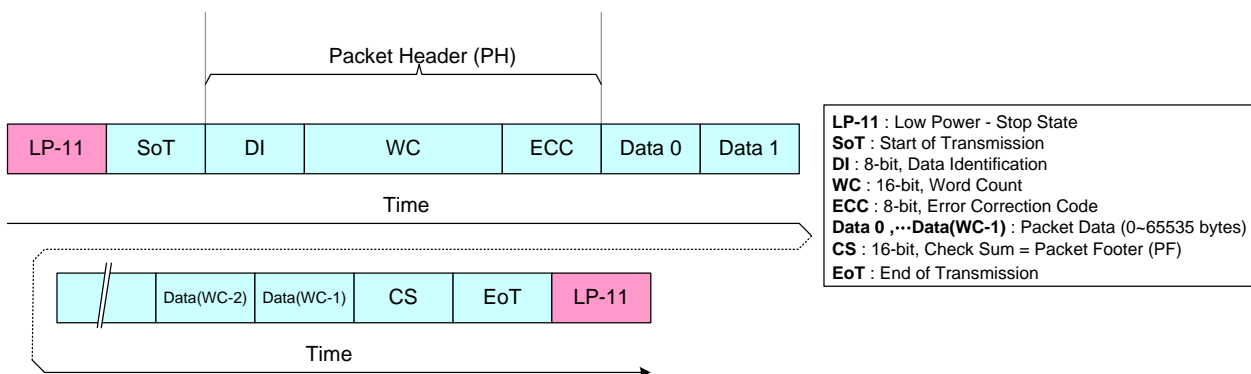

Figure 32: Long Packet (LPa) Structure

Notes:

1. Figure 31 and Figure 32 present a single packet sending (= Includes LP-11, SoT and EoT for each packet sending).
2. The other possibility is that SoT, EoT and LP-11 are not needed between packets if packets are sent in multiple packet format, e.g.
 - LP-11 => SoT => SPa => LPa => SPa => SPa => EoT => LP-11
 - LP-11 => SoT => SPa => SPa => SPa => EoT => LP-11
 - LP-11 => SoT => LPa => LPa => LPa => EoT => LP-11

4.1.3.1.1. Bit Order of the Byte on Packets

The bit order of the byte, what is used in packets, is that the Least Significant Bit (LSB) of the byte is sent first, and the Most Significant Bit (MSB) is sent last. The order is illustrated for reference purposes below.

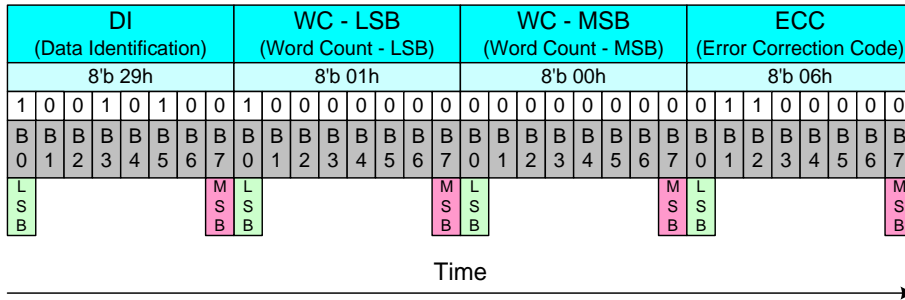

Figure 33: Bit Order of the Byte on Packets

4.1.3.1.2. Byte Order of the Multiple Byte Information on Packets

Byte order of the multiple bytes information, what is used in packets, is that the Least Significant (LS) Byte of the information is sent first and the Most Significant (MS) Byte is sent last. For example, Word Count (WC) consists of 2 bytes (= 16 bits); while the LS byte is sent first and the MS byte is sent last. The order is illustrated for reference purposes below.

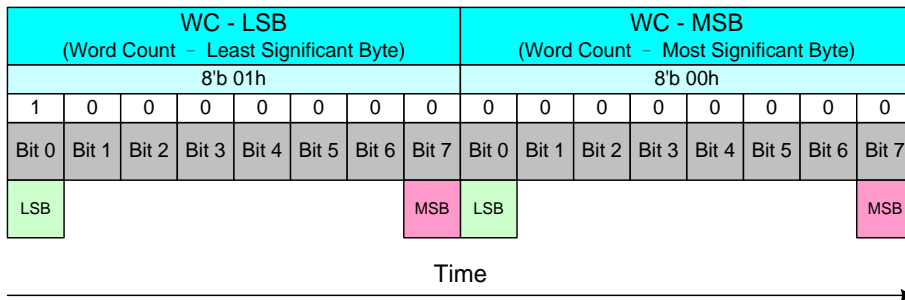

Figure 34: Byte Order of the Multiple Byte Information on Packets

4.1.3.1.3. Packet Header (PH)

The packet header always consists of 4 bytes. The content of these 4 bytes are different for Short Packet (SPa) and Long Packet (LPa).

Short Packet (SPa):

- 1st byte: Data Identification (DI) => Identify that this is a Short Packet (SPa)
- 2nd and 3rd bytes: Packet Data (PD), Data 0 and 1
- 4th byte: Error Correction Code (ECC)

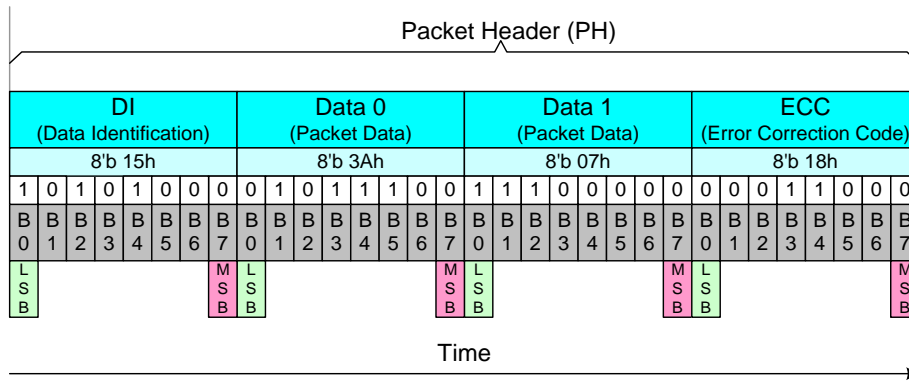

Figure 35: Packet Header (PH) in a Short Packet (SPa)

Long Packet (LPa):

- 1st byte: Data Identification (DI) => Identify that this is a Long Packet (LPa)
- 2nd and 3rd bytes: Word Count (WC)
- 4th byte: Error Correction Code (ECC)

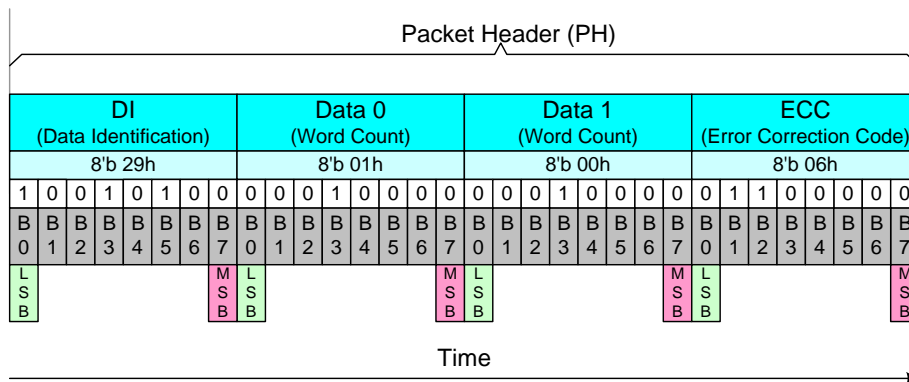

Figure 36: Packet Header (PH) in a Long Packet (LPa)

4.1.3.1.3.1. Data Identification (DI)

Data Identification (DI) is a part of the Packet Header (PH), and it consists of 2 parts:

- Virtual Channel (VC), 2 bits, DI [7...6]
- Data Type (DT), 6 bits, DI [5...0]

The Data Identification (DI) structure is illustrated, see the figure below.

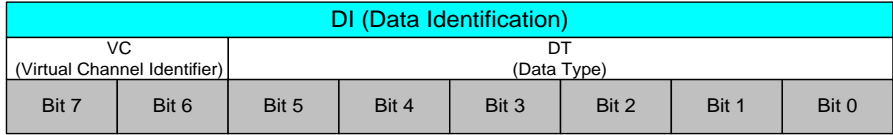

Figure 37: Data Identification (DI) Structure

Data Identification (DI) in the Packet Header (PH) is illustrated for reference purposes below.

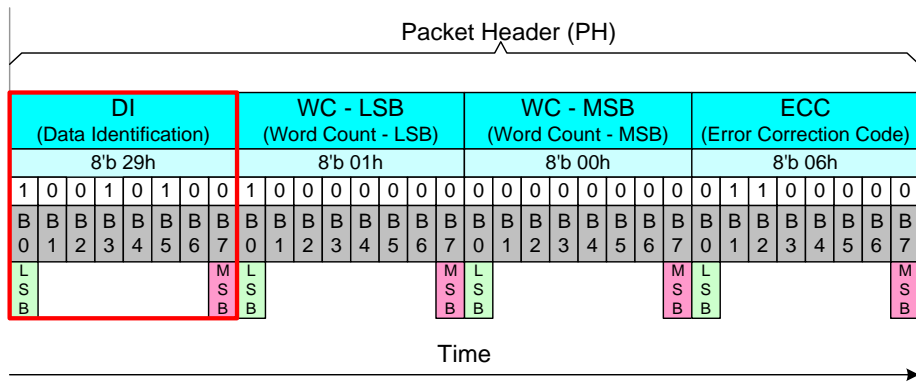

Figure 38: Data Identification (DI) on the Packet Header (PH)

4.1.3.1.3.1.1. Virtual Channel (VC)

Virtual Channel (VC) is a part of Data Identification (DI [7...6]) structure, and it is used to address where a packet is to be sent from the MCU. Bits of the Virtual Channel (VC) are illustrated for reference purposes below.

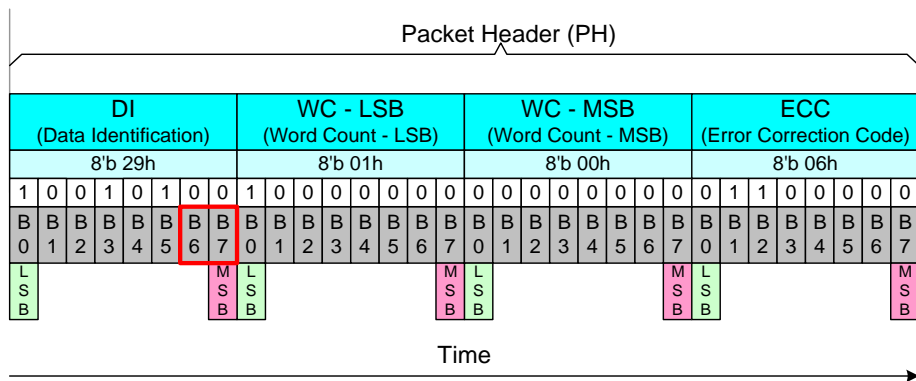

Figure 39: Virtual Channel (VC) on the Packet Header (PH)

Virtual Channel (VC) can assign 4 different channels for 4 different display modules. Devices will use the same virtual channel as which the MCU uses to send packets to them, e.g.

The information contained herein is the exclusive property of ILI Technology Corp. and shall not be distributed, reproduced, or disclosed in whole or in part without prior written permission of ILI Technology Corp.

- ◆ The MCU uses the virtual channel 0 when it sends packets to the ILI9881C-0D
- ◆ The ILI9881C-0D also uses the virtual channel 0 when it sends packets to the MCU

This functionality is illustrated below.

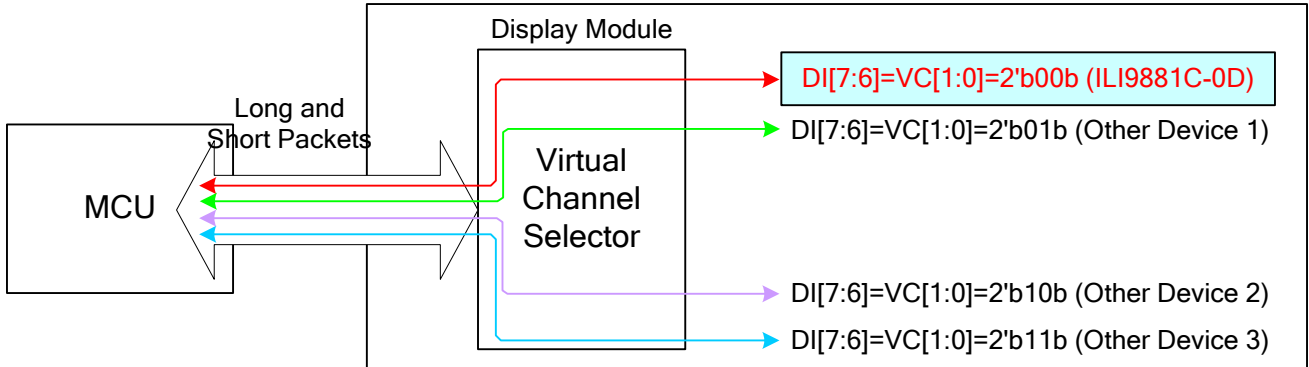

Figure 40: Virtual Channel (VC) Configuration

Virtual Channel (VC) is always 0 (DI [7..6] = VC [1..0] = 00b) when the MCU sends “End of Transmission Packet” to the display module. See the section “4.1.3.2.1.7 End of Transmission Packet (EoTP)”.

This display module does not support the virtual channel selector for other devices (1 to 3) when the only possible virtual channel (VC [1..0]) is 00b for the ILI9881C-0D.

4.1.3.1.3.1.2. Data Type (DT)

Data Type (DT) is a part of Data Identification (DI [5...0]) structure, and it is used to define the type of the used data in a packet. Bits of the Data Type (DT) are illustrated for reference purposes below.

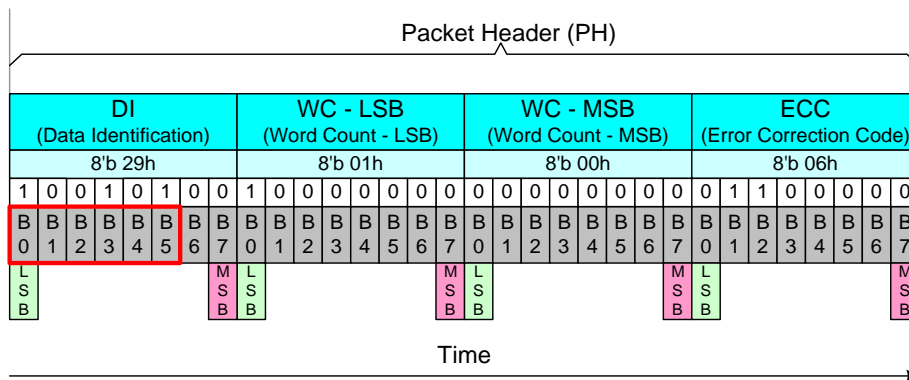

Figure 41: Data Type (DT) on the Packet Header (PH)

This Data Type (DT) also defines the used packet is a Short Packet (SPa) or a Long Packet (LPa). Data Types (DT) are different from the MCU to the display module (or other devices) and vice versa. These Data Types (DT) are defined in the tables below.

Table 7: Data Type (DT) from the MCU to the Display Module

From the MCU to the Display Module								
Bit5	Bit4	Bit3	Bit2	Bit1	Bit0	Hex	Description	Short/Long Packet
0	0	0	0	0	1	01	Sync Event, V Sync Start	SPa (Short Packet)
0	1	0	0	0	1	11	Sync Event, V Sync End	SPa (Short Packet)
1	0	0	0	0	1	21	Sync Event, H Sync Start	SPa (Short Packet)
1	1	0	0	0	1	31	Sync Event, H Sync End	SPa (Short Packet)
0	0	1	0	0	0	08	End of Transmission Packet (EoTP) ^{Note1}	SPa (Short Packet)
0	0	0	0	1	0	02	Color Mode Off Command	SPa (Short Packet)
0	1	0	0	1	0	12	Color Mode On Command	SPa (Short Packet)
1	0	0	0	1	0	22	Shut Down Peripheral Command	SPa (Short Packet)
1	1	0	0	1	0	32	Turn On Peripheral Command	SPa (Short Packet)
0	0	0	0	1	1	03	Generic Short WRITE, no parameters	SPa (Short Packet)
0	1	0	0	1	1	13	Generic Short WRITE, 1 parameters	SPa (Short Packet)
1	0	0	0	1	1	23	Generic Short WRITE, 2 parameters	SPa (Short Packet)
0	0	0	1	0	0	04	Generic Short READ, no parameters	SPa (Short Packet)
0	1	0	1	0	0	14	Generic Short READ, 1 parameters	SPa (Short Packet)
1	0	0	1	0	0	24	Generic Short READ, 2 parameters	SPa (Short Packet)
0	0	0	1	0	1	05	DCS Write, No Parameter	SPa (Short Packet)
0	1	0	1	0	1	15	DCS Write, 1 Parameter	SPa (Short Packet)
0	0	0	1	1	0	06	DCS Read, No Parameter	SPa (Short Packet)
1	1	0	1	1	1	37	Set Maximum Return Packet Size	SPa (Short Packet)
0	0	1	0	0	1	09	Null Packet, No Data, ^{Note2}	LPa (Long Packet)
0	1	1	0	0	1	19	Blanking Packet, no data	LPa (Long Packet)
1	0	1	0	0	1	29	Generic Long Write	LPa (Long Packet)
1	1	1	0	0	1	39	DCS Write Long	LPa (Long Packet)
0	0	1	1	1	0	0E	Packed Pixel Stream, 16-bit RGB, 5-6-5 Format	LPa (Long Packet)
0	1	1	1	1	0	1E	Packed Pixel Stream, 18-bit RGB, 6-6-6 Format	LPa (Long Packet)
1	0	1	1	1	0	2E	Loosely Packed Pixel Stream, 18-bit RGB, 6-6-6 Format	LPa (Long Packet)
1	1	1	1	1	0	3E	Packed Pixel Stream, 24-bit RGB, 8-8-8 Format	LPa (Long Packet)
x	x	0	0	0	0	x0	DO NOT USE	
x	x	1	1	1	1	xF	All unspecified codes are reserved	

Notes:

1. This can be used when the MCU wants to make sure that it is the end of the transmission in High Speed Data Transferring (HSDDT) mode.
2. This can be used when data lanes are to be kept in High Speed Data Transferring (HSDDT) Mode.

Table 8: Data Type (DT) from the Display Module to the MCU

From the Display Module to the MCU							Description	Short/Long Packet
Bit5	Bit4	Bit3	Bit2	Bit1	Bit0	Hex		
0	0	0	0	1	0	02	Acknowledge with Error Report	SPa (Short Packet)
0	0	1	0	0	0	08	End of Transmission Packet (EoTP)	SPa (Short Packet)
0	1	0	0	0	1	11	Generic Short READ Response, 1 byte returned	SPa (Short Packet)
0	1	0	0	1	0	12	Generic Short READ Response, 2 byte returned	SPa (Short Packet)
0	1	1	0	1	0	1A	Generic Long READ Response	LPa (Long Packet)
0	1	1	1	0	0	1C	DCS Read Long Response	LPa (Long Packet)
1	0	0	0	0	1	21	DCS Read Short Response, 1 byte returned	SPa (Short Packet)
1	0	0	0	1	0	22	DCS Read Short Response, 2 byte returned	SPa (Short Packet)

The receiver will ignore other Data Types (DT) if they are not defined in Table 7 and Table 8.

4.1.3.1.3.2. Packet Data (PD) in a Short Packet (SPa)

Packet Data (PD) of the Short Packet (SPa) is placed after Data Type (DT) of the Data Identification (DI) and indicates a Short Packet (SPa) is to be sent. Packet Data (PD) of a Short Packet (SPa) consists of 2 data bytes: Data 0 and Data 1. The sending order of the Packet Data (PD) is that Data 0 is sent first and the Data 1 is sent last. Bits of Data 1 are set to 0 if the information length is 1 byte. Packet Data (PD) of a Short Packet (SPa), when the length of the information is 1 or 2 bytes and Virtual Channel (VC) is 0, are illustrated for reference purposes below.

Packet Data (PD) information:

- Data 0: 26hex (Display Command Set (DCS) with 1 Parameter => DI (Data Type (DT)) = 15hex)
- Data 1: 01hex (DCS's parameter)

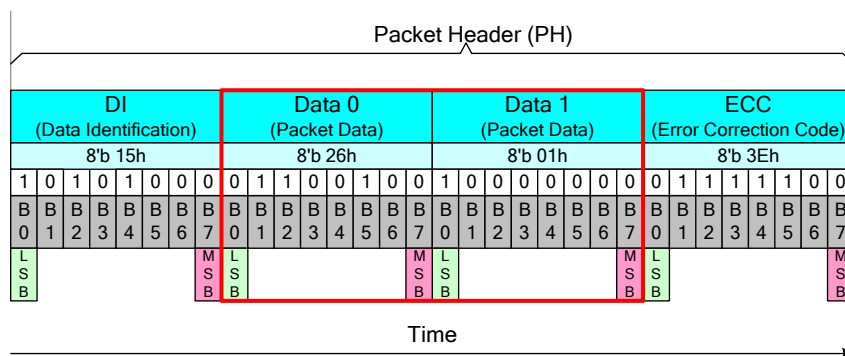

Figure 42: Packet Data (PD) for Short Packet (SPa), 2 Bytes Information

Packet Data (PD) information:

- Data 0: 10hex (DCS without parameter => DI (Data Type (DT)) = 05hex)
- Data 1: 00hex (Null)

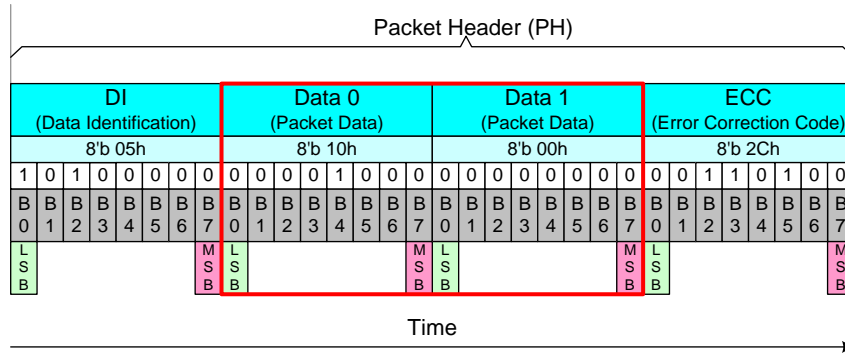

Figure 43: Packet Data (PD) for Short Packet (SPa), 1 Byte Information

4.1.3.1.3.3. Word Count (WC) in a Long Packet (LPa)

Word Count (WC) of the Long Packet (LPa) is placed after Data Type (DT) of the Data Identification (DI) and indicates that a Long Packet (LPa) is to be sent. Word Count (WC) indicates the amount of data bytes of the Packet Data (PD) that is to be sent after the Packet Header (PH). The location of the Word Count (WC) in a Long Packet is the same as which of the Packet Data (PD) in a Short Packet (SPa), as shown in Figure 45. Word Count (WC) of the Long Packet (LPa) consists of 2 bytes. The sending order of these 2 bytes of the Word Count (WC) is that the Least Significant (LS) Byte is sent first, and the Most Significant (MS) Byte is sent last. Word Count (WC) of a Long Packet (LPa) is illustrated for reference purposes below.

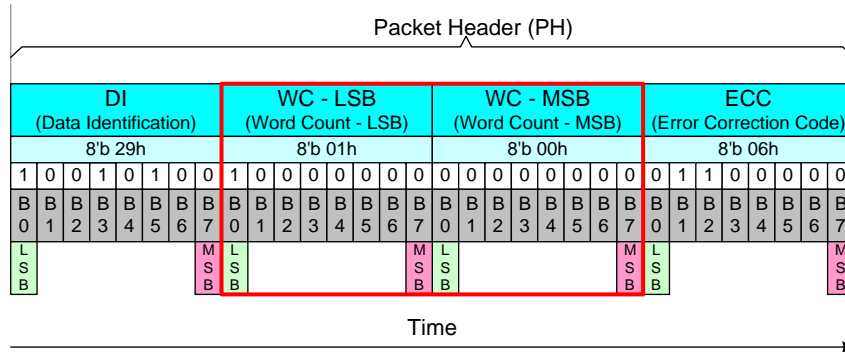

Figure 44: Word Count (WC) in a Long Packet (LPa)

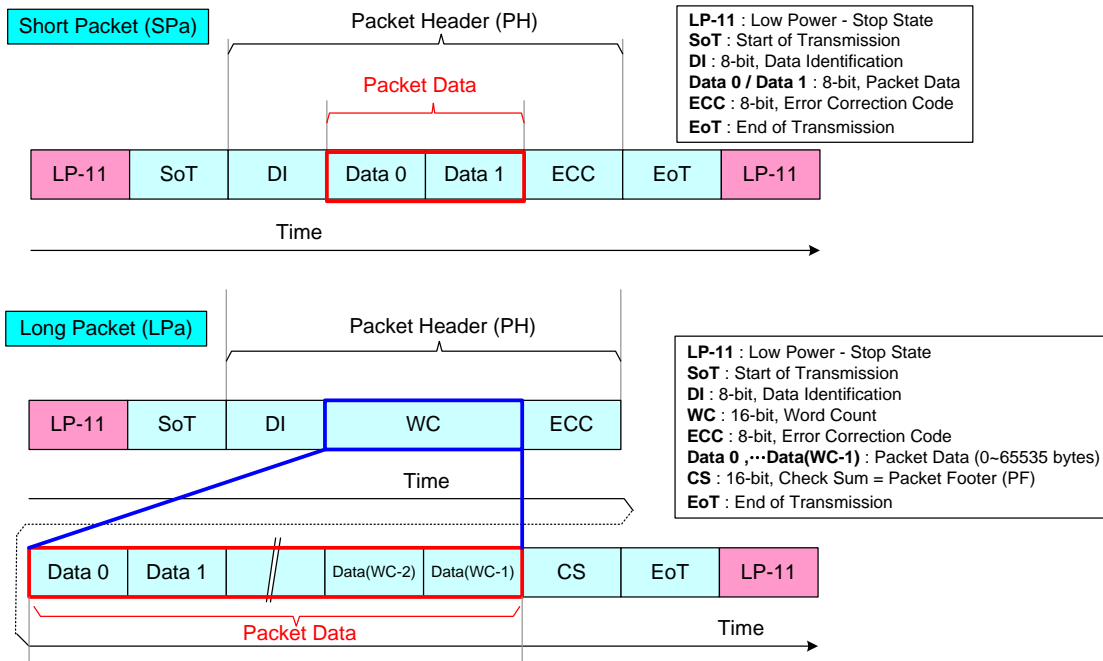

Figure 45: Packet Data in Short and Long Packets

4.1.3.1.3.4. Error Correction Code (ECC)

The Error Correction Code (ECC) is a part of Packet Header (PH) and its purpose is to identify an error or errors. The ECC protects the following fields:

- ❖ Short Packet (SPa): Data Identification (DI) byte (8 bits: D [0...7]), Packet Data (PD) bytes (16 bits: D [8...23]) and ECC (8 bits: P [0...7])
- ❖ Long Packet (LPa): Data Identification (DI) byte (8 bits: D [0...7]), Word Count (WC) bytes (16 bits: D [8...23]) and ECC (8 bits: P [0...7])

D [23...0] and P [7...0] are illustrated for reference purposes below.

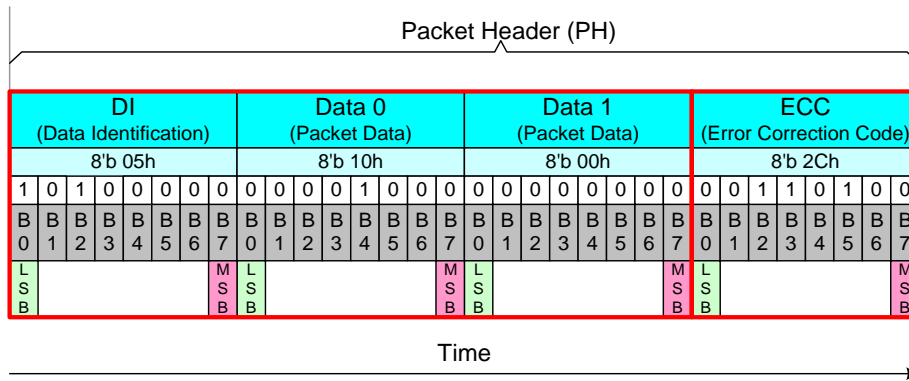

Figure 46: D [23...0] and P [7...0] in a Short Packet (SPa)

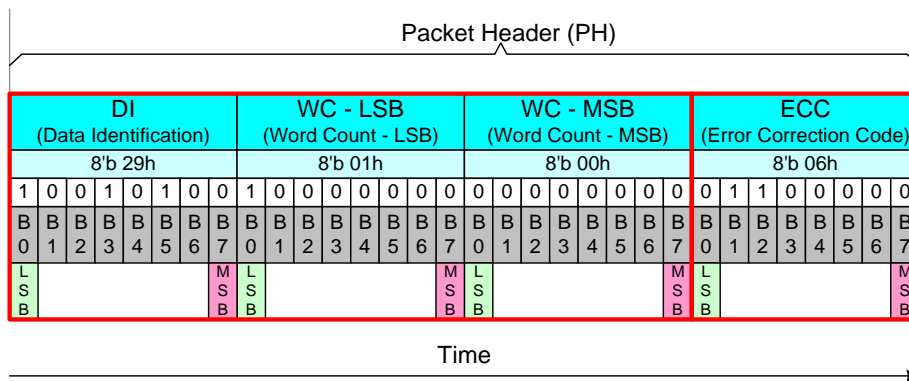

Figure 47: D [23...0] and P [7...0] in a Long Packet (LPa)

Error Correction Code (ECC) can recognize one or several error(s) and can only correct one-bit error. Bits (P [7...0]) of the Error Correction Code (ECC) are defined, where the symbol '^' presents the XOR function (Pn is 1 if there is odd number of 1, and Pn is 0 if there is even number of 1), as follows.

- P7 = 0
- P6 = 0
- P5 = D10^D11^D12^D13^D14^D15^D16^D17^D18^D19^D21^D22^D23
- P4 = D4^D5^D6^D7^D8^D9^D16^D17^D18^D19^D20^D22^D23
- P3 = D1^D2^D3^D7^D8^D9^D13^D14^D15^D19^D20^D21^D23
- P2 = D0^D2^D3^D5^D6^D9^D11^D12^D15^D18^D20^D21^D22

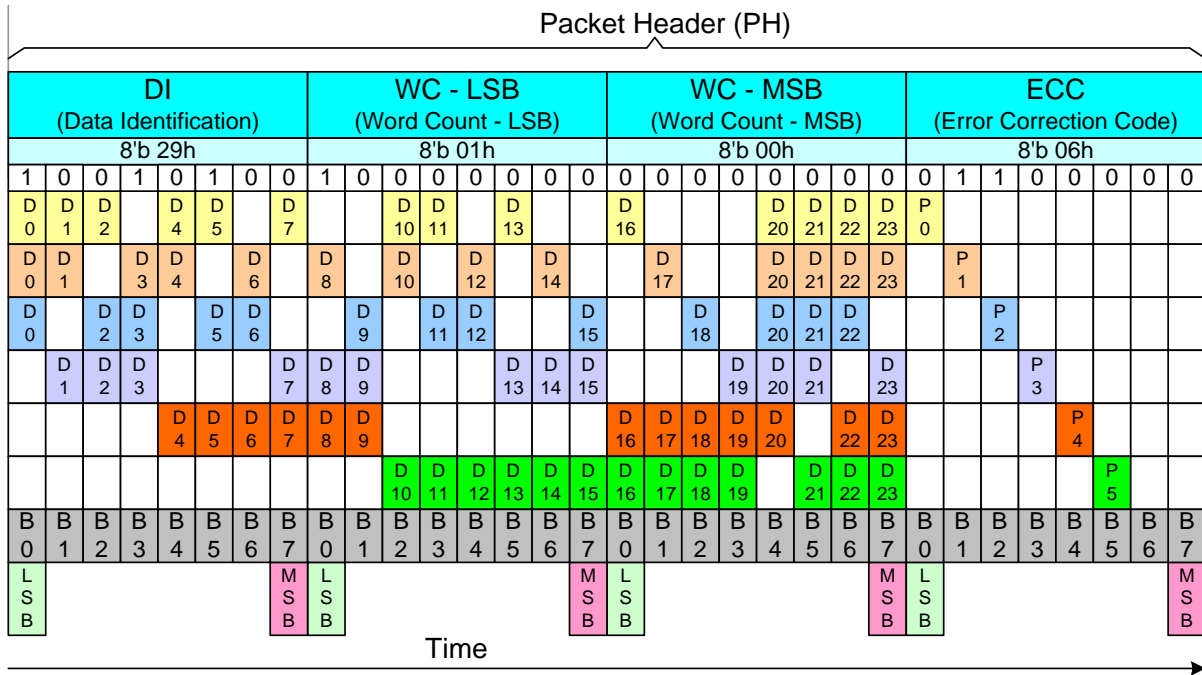

Figure 49: XOR Function on a Long Packet (LPa)

The transmitter (= the MCU or the Display Module) will send data bits D [23...0] and Error Correction Code (ECC) P [7...0]. The receiver (= the Display module or the MCU) will calculate the Internal Error Correction Code (IECC) and compare the received Error Correction Code (ECC) and the Internal Error Correction Code (IECC). This comparison is done when each power bit of ECC and IECC have performed the XOR function. The result of this function is PO [7...0]. This functionality, where the transmitter is the MCU and the receiver is the display module, is illustrated for reference purposes below.

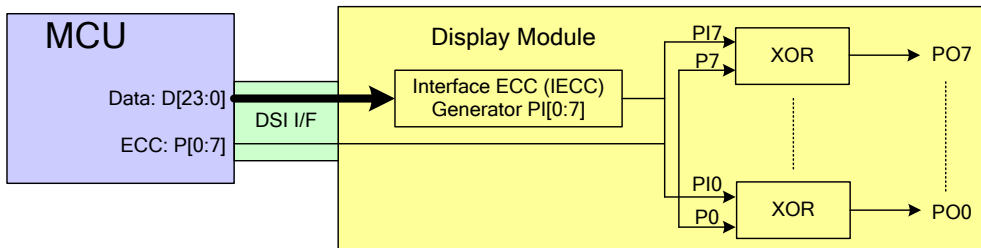

Figure 50: Internal Error Correction Code (IECC) on the Display Module (= the Receiver)

The sent data bits (D [23...0]) and ECC (P [7...0]) are correctly received if the value of the PO [7...0] is 00h.
The sent data bits (D [23...0]) and ECC (P [7...0]) are not correctly received if the value of the PO [7...0] is not 00h.

ECC P[7...0]	1	1	0	0	0	0	0	0	03h
IECC PI[7...0]	1	1	0	0	0	0	0	0	03h
XOR(ECC, IECC) => PO[7...0]	0	0	0	0	0	0	0	0	= 00h => No Error
	L							M	
	S							S	
	B							B	

Figure 51: Internal XOR Calculation between ECC and IECC Values – No Error

ECC P[7...0]	1	1	0	0	0	0	0	0	03h
IECC PI[7...0]	1	1	1	1	0	0	0	0	0Fh
XOR(ECC, IECC) => PO[7...0]	0	0	1	1	0	0	0	0	= 0Ch => Error
	L							M	
	S							S	
	B							B	

Figure 52: Internal XOR Calculation between ECC and IECC Values - Error

The received Error Correction Code (ECC) can be 00h when the Error Correction Code (ECC) function is not used for data values D [23...0] on the transmitter side. The number of the errors (one or more) can be defined when the value of the PO [7...0] is compared to the values in the following table.

Table 9: One Bit Error Value of the Error Correction Code (ECC)

Data Bit	PO7	PO6	PO5	PO4	PO3	PO2	PO1	PO0	Hex
D [0]	0	0	0	0	0	1	1	1	07h
D [1]	0	0	0	0	1	0	1	1	0Bh
D [2]	0	0	0	0	1	1	0	1	0Dh
D [3]	0	0	0	0	1	1	1	0	0Eh
D [4]	0	0	0	1	0	0	1	1	13h
D [5]	0	0	0	1	0	1	0	1	15h
D [6]	0	0	0	1	0	1	1	0	16h
D [7]	0	0	0	1	1	0	0	1	19h
D [8]	0	0	0	1	1	0	1	0	1Ah
D [9]	0	0	0	1	1	1	0	0	1Ch
D [10]	0	0	1	0	0	0	1	1	23h
D [11]	0	0	1	0	0	1	0	1	25h
D [12]	0	0	1	0	0	1	1	0	26h
D [13]	0	0	1	0	1	0	0	1	29h
D [14]	0	0	1	0	1	0	1	0	2Ah
D [15]	0	0	1	0	1	1	0	0	2Ch
D [16]	0	0	1	1	0	0	0	1	31h
D [17]	0	0	1	1	0	0	1	0	32h
D [18]	0	0	1	1	0	1	0	0	34h
D [19]	0	0	1	1	1	0	0	0	38h
D [20]	0	0	0	1	1	1	1	1	1Fh
D [21]	0	0	1	0	1	1	1	1	2Fh
D [22]	0	0	1	1	0	1	1	1	37h
D [23]	0	0	1	1	1	0	1	1	3Bh

An error is detected if the value of the PO [7...0] is in Table 9, and the receiver can correct this one bit error

because this found value also defines the location of the corrupt bit, e.g.

- ❖ PO [7...0] = 0Eh
- ❖ The bit of the data (D [23...0]), that is not correct, is D [3]

More than one error is detected if the value of the PO [7...0] is not in Table 9, for example, PO [7...0] = 0Ch.

4.1.3.1.4. Packet Data (PD) in a Long Packet (LPa)

Packet Data (PD) of a Long Packet (LPa) is placed after the Packet Header (PH) of a Long Packet (LPa). The amount of the data bytes is defined in the section “4.1.3.1.3.3 Word Count (WC) in a Long Packet (LPa)”.

4.1.3.1.5. Packet Footer (PF) in a Long Packet (LPa)

Packet Footer (PF) of a Long Packet (LPa) is placed after the Packet Data (PD) of a Long Packet (LPa). The Packet Footer (PF) is a checksum value that is calculated from the Packet Data of the Long Packet (LPa). The checksum uses a 16-bit Cyclic Redundancy Check (CRC) value which is generated by a polynomial $X^{16}+X^{12}+X^5+X^0$, as illustrated below.

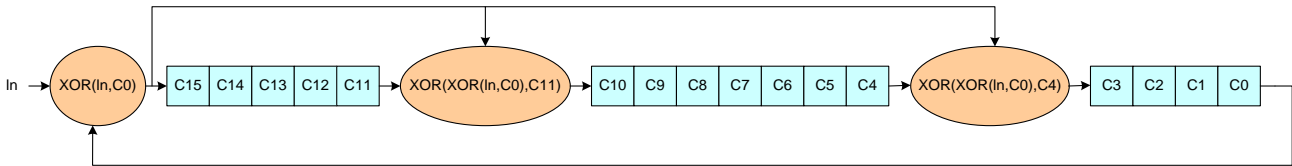

Figure 53: 16-bit Cyclic Redundancy Check (CRC) Calculation

The 16-bit Cyclic Redundancy Check (CRC) generator is initialized to FFFFh before calculations. The Most Significant Bit (MSB) of the data byte of the Packet Data (PD) is the first bit which is inputted into the 16-bit Cyclic Redundancy Check (CRC). An example of the 16-bit Cyclic Redundancy Check (CRC), where the Packet Data (PD) of a Long Packet (LPa) is 01h, is illustrated (step-by-step) below.

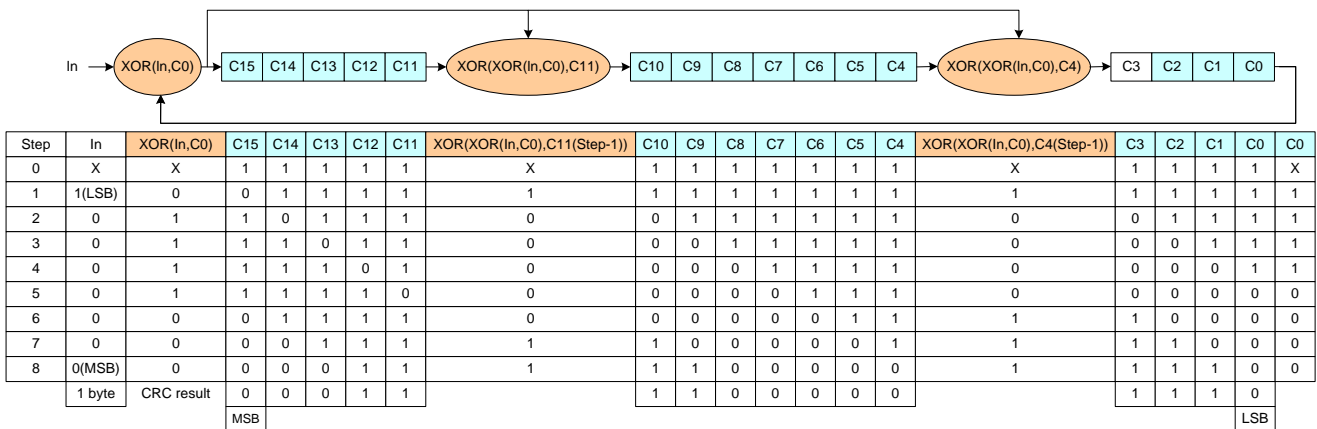

Figure 54: CRC Calculation – Packet Data (PD) is 01h

The value of the Packet Footer (PF) is 1E0Eh in this example (Command 01h has been sent), and is illustrated

The information contained herein is the exclusive property of ILI Technology Corp. and shall not be distributed, reproduced, or disclosed in whole or in part without prior written permission of ILI Technology Corp.

below.

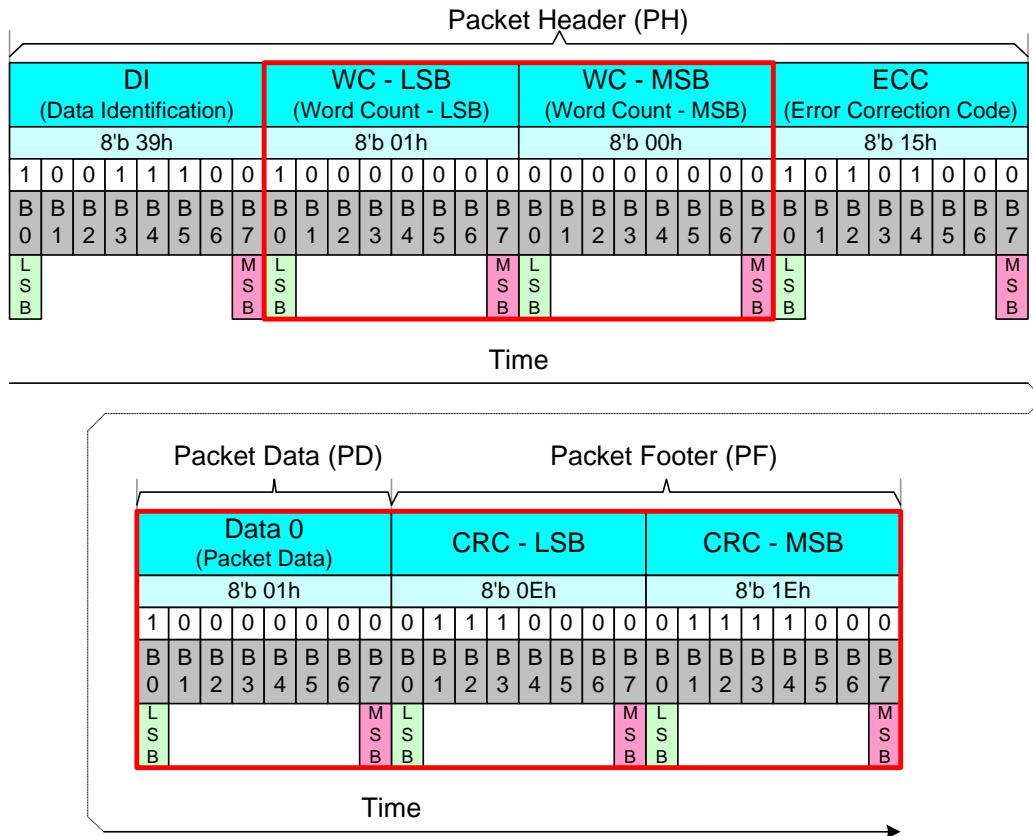

Figure 55: Packet Footer (PF) Example

The receiver calculates its checksum value from the received Packet Data (PD). The receiver compares its checksum and the Packet Footer (PF) that the transmitter has sent. The received Packet Data (PD) and Packet Footer (PF) are correct if the checksum of the receiver and Packet Footer (PF) are equal. The received Packet Data (PD) and Packet Footer (PF) are not correct if the checksum of the receiver and Packet Footer (PF) are not equal.

4.1.3.2. Packet Transmissions

4.1.3.2.1. Packet from the MCU to the Display Module

4.1.3.2.1.1. Display Command Set (DCS)

Display Command Set (DCS), defined in the section “5.3Page 0 Command Description”, is used from the MCU to the display module. This Display Command Set (DCS) is always defined in the Data 0 of the Packet Data (PD), and is included in Short Packet (SPa) and Long packet (LPa), as illustrated below.

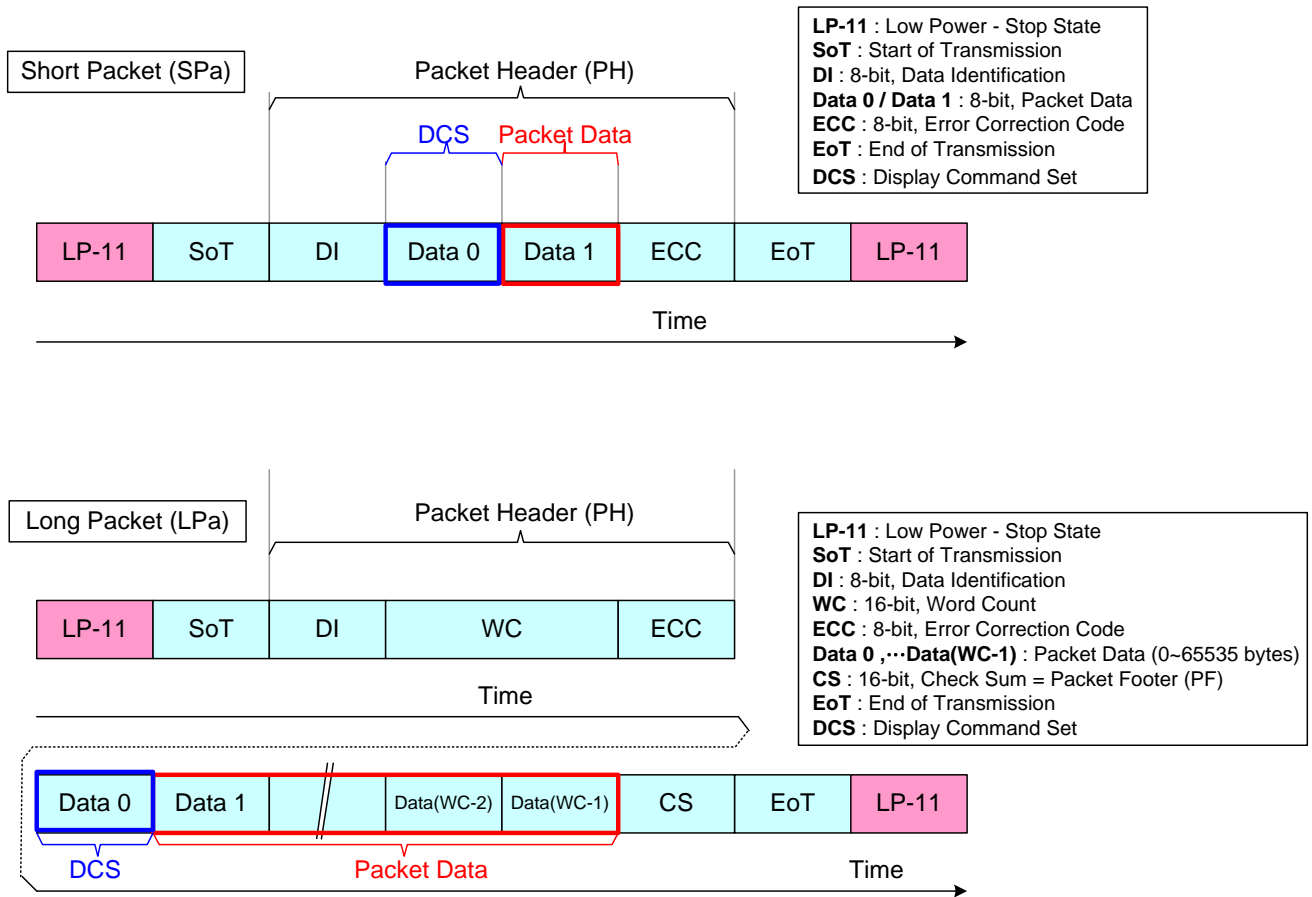

Figure 56: Display Command Set (DCS) in Short Packet (SPa) and Long Packet (LPa)

4.1.3.2.1.2. Display Command Set (DCS) Write, No Parameter (DCSWN-S)

“Display Command Set (DCS) Write, No Parameter”, which is defined in Data Type (DT, 00 0101b), is always used in a Short Packet (SPa) from the MCU to the display module. These commands are defined in a table below.

Table 10: Display Command Set (DCS) Write, No Parameters (DCSWN-S)

Command
NOP (00h)
Software Reset (01h)
Sleep In(10h)
Sleep Out (11h)
Normal Display Mode On (13h)
All Pixel Off (22h)
All Pixel On (23h)
Display Off (28h)
Display ON (29h)
Tearing Effect Line OFF (34h)
Idle Mode Off (38h)
Idle Mode On (39h)
Stop Transition (59h)

A Short Packet (SPa) is defined as:

- Data Identification (DI)
 - ✧ Virtual Channel (VC, DI [7...6]): 00b
 - ✧ Data Type (DT, DI [5...0]): 00 0101b
- Packet Data (PD)
 - ✧ Data 0: “Sleep In (10h)”, Display Command Set (DCS)
 - ✧ Data 1: Always 00hex
- Error Correction Code (ECC)

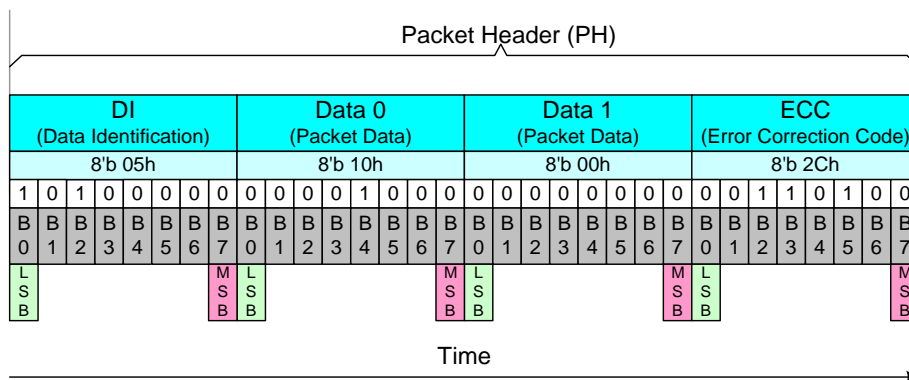

Figure 57: Display Command Set (DCS) Write, No Parameter (DCSWN-S) - Example

4.1.3.2.1.3. Display Command Set (DCS) Write, 1 Parameter (DCSW1-S)

“Display Command Set (DCS) Write, 1 Parameter” (DCSW1-S), which is defined in Data Type (DT, 01 0101b), is always used in a Short Packet (SPa) from the MCU to the display module. These commands are defined in the table below.

Table 11: Display Command Set (DCS) Write, 1 Parameter (DCSW1-S)

Command
Gamma Curve Set (26h)
Memory Write (2Ch), ^{Note}
Tearing Effect Line ON(35h)
Memory Access Control (36h)
Interface Pixel Format (3Ah)
Memory Write Continue (3Ch), ^{Note}
Write Display Brightness (51h)
Write CTRL Display (53h)
Write Power Save (55h)
Write Idle Mode Color (80h)

Note: One Subpixel has been written

A Short Packet (SPa) is defined as:

- Data Identification (DI)
 - ✧ Virtual Channel (VC, DI [7...6]): 00b
 - ✧ Data Type (DT, DI [5...0]): 01 0101b
- Packet Data (PD)
 - ✧ Data 0: “Gamma Set (26h)”, Display Command Set (DCS)
 - ✧ Data 1: 01hex, Parameter of the DCS
- Error Correction Code (ECC)

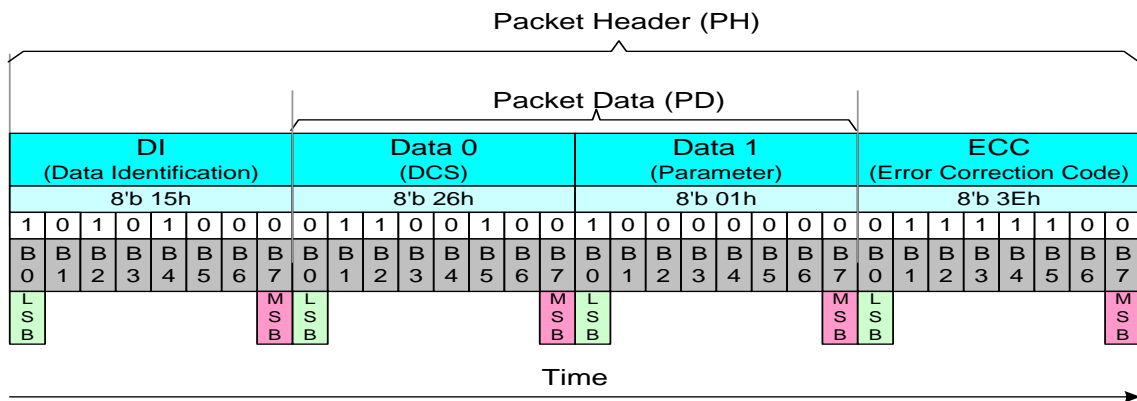

Figure 58: Display Command Set (DCS) Write, 1 Parameter (DCSW1-S) – Example

4.1.3.2.1.4. Display Command Set (DCS) Write Long (DCSW-L)

“Display Command Set (DCS) Write Long” (DCSW-L), which is defined in Data Type (DT, 11 1001b), is always used in a Long Packet (LPa) from the MCU to the display module. Command (No Parameters) and Write (1 or more parameters) are defined in a table below.

Table 12: Display Command Set (DCS) Write Long (DCSW-L)

Command
NOP (00h), ^{Note 1}
Software Reset (01h), ^{Note 1}
Sleep In(10h), ^{Note 1}
Sleep Out (11h), ^{Note 1}
Normal Display Mode On (13h), ^{Note 1}
All Pixel Off (22h), ^{Note 1}
All Pixel On (23h), ^{Note 1}
Gamma Curve Set (26h), ^{Note 2}
Display Off (28h), ^{Note 1}
Display ON (29h), ^{Note 1}
Memory Write (2Ch), ^{Note 2}
Tearing Effect Line OFF (34h), ^{Note 1}
Tearing Effect Line ON (35h), ^{Note 2}
Memory Access Control (36h), ^{Note 2}
Idle Mode Off (38h), ^{Note 1}
Idle Mode On (39h), ^{Note 1}
Interface Pixel Format (3Ah), ^{Note 2}
Memory Write Continue (3Ch), ^{Note 2}
Set Tear Scan Line(44h)
Write Display Brightness (51h), ^{Note 2}
Write CTRL Display (53h), ^{Note 2}
Write Power Save(55h), ^{Note 2}
Stop Transition (59h), ^{Note 1}
Write CABC Minimum Brightness (5Eh), ^{Note 2}
Set Transition Time(68h)
Write Idle Mode Color (80h), ^{Note 2}

Notes:

1. Short Packet (SPa) can also be used; See the section “4.1.3.2.1.2 Display Command Set (DCS) Write, No Parameter (DCSWN-S)”.
2. Short Packet (SPa) can also be used; See the section “4.1.3.2.1.3 Display Command Set (DCS) Write, 1 Parameter (DCSW1-S)”.

A Long Packet (LPa) with one command (No Parameter) is defined as:

- Data Identification (DI)
 - ✧ Virtual Channel (VC, DI [7...6]): 00b
 - ✧ Data Type (DT, DI [5...0]): 11 1001b
- Word Count (WC)
 - ✧ Word Count (WC): 0001h
- Error Correction Code (ECC)

- Packet Data (PD): Data 0: "Sleep In (10h)", Display Command Set (DCS)
- Packet Footer (PF)

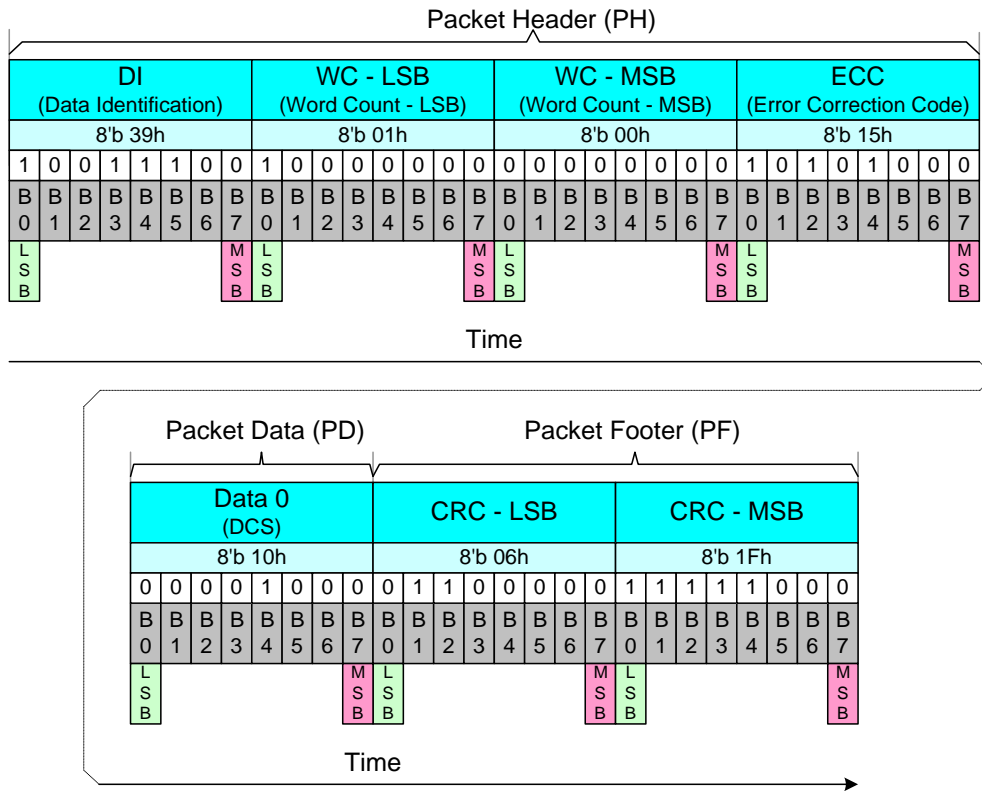

Figure 59: Display Command Set (DCS) Write Long (DCSW-L) with DCS Only - Example

A Long Packet (LPa) with one Write (1 parameter) is defined as:

- Data Identification (DI)
 - ✧ Virtual Channel (VC, DI [7...6]): 00b
 - ✧ Data Type (DT, DI [5...0]): 11 1001b
- Word Count (WC)
 - ✧ Word Count (WC): 0002h
- Error Correction Code (ECC)
- Packet Data (PD):
 - ✧ Data 0: "Gamma Set (26h)", Display Command Set (DCS)
 - ✧ Data 1: 01hex, Parameter of the DCS
- Packet Footer (PF)

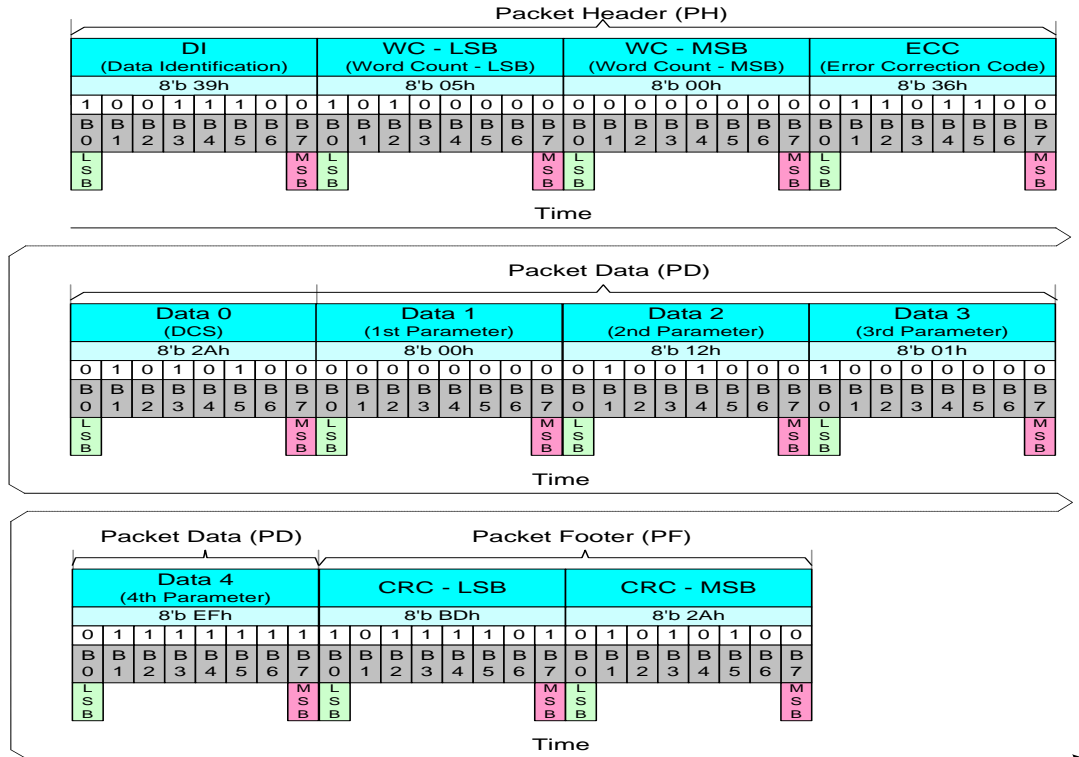

Figure 61: Display Command Set (DCS) Write Long with DCS and 4 Parameters - Example

4.1.3.2.1.5. Display Command Set (DCS) Read, No Parameter (DCSRN-S)

“Display Command Set (DCS) Read, No Parameter” (DCSRN-S), which is defined in Data Type (DT, 00 0110b), is always used in a Short Packet (SPa) from the MCU to the display module. These commands are defined in the table below.

Table 13: Display Command Set (DCS) Read, No Parameter (DCSRN-S)

Command
Read Number of the Errors on DSI (05h)
Read Display Power Mode (0Ah)
Read Display MADCTL (0Bh)
Read Display Pixel Format (0Ch)
Read Display Image Mode (0Dh)
Read Display Signal Mode (0Eh)
Read Display Self-Diagnostic Result (0Fh)
Get Tear Scan Line(45h)
Read Display Brightness Value (52h)
Read CTRL Value Display (54h)
Read Power Save (56h)
Read CABC Minimum Brightness (5Fh)
Get Transition Time(69h)
Read Idle Mode Color(81h)
Read DDB Start (A1h)
Read DDB Continue (A8h)
Read First Checksum(AAh)
Read Continue Checksum (AFh)
Read ID1 (DAh)
Read ID2 (DBh)
Read ID3 (DCh)

The MCU has to define to the display module the maximum size of the returned packet. The command, which is used for this purpose, is “Set Maximum Return Packet Size” (SMRPS-S), which Data Type (DT) is 11 0111b and is used in a Short Packet (SPa) before the MCU can send “Display Command Set (DCS) Read, No Parameter” to the display module. This sequence is illustrated for reference purposes below.

Step 1:

The MCU sends “Set Maximum Return Packet Size” (Short Packet (SPa)) (SMRPS-S) to the display module when it wants to return one byte from the display module.

- Data Identification (DI)
 - ✧ Virtual Channel (VC, DI [7...6]): 00b
 - ✧ Data Type (DT, DI [5...0]): 11 0111b
- Maximum Return Packet Size (MRPS)
 - ✧ Data 0: 01hex
 - ✧ Data 1: 00hex
- Error Correction Code (ECC)

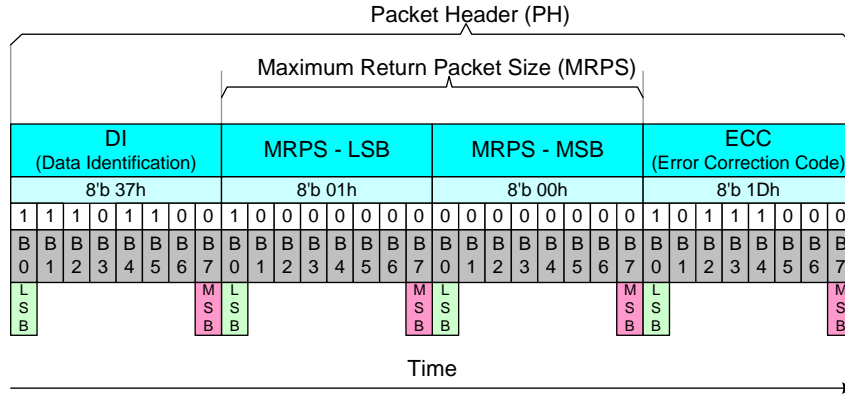

Figure 62: Set Maximum Return Packet Size (SMRPS-S) - Example

Step 2:

The MCU wants to receive the value of the “Read ID1 (DAh)” from the display module when the MCU sends “Display Command Set (DCS) Read, No Parameter” to the display module.

- Data Identification (DI)
 - ✧ Virtual Channel (VC, DI [7...6]): 00b
 - ✧ Data Type (DT, DI [5...0]): 00 0110b
- Packet Data (PD)
 - ✧ Data 0: “Read ID1 (DAh)”, Display Command Set (DCS)
 - ✧ Data 1: Always 00hex
- Error Correction Code (ECC)

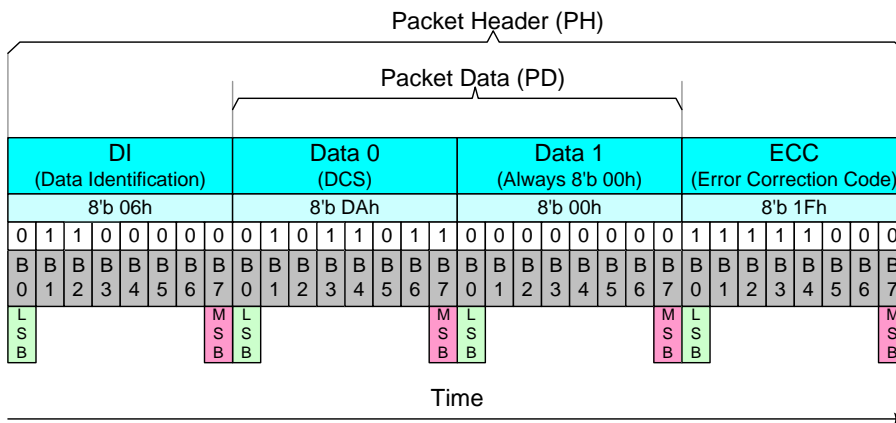

Figure 63: Display Command Set (DCS) Read, No Parameter (DCSRN-S) - Example

Step 3:

The display module can send 2 different information to the MCU after Bus Turnaround (BTA):

1. An acknowledge with Error Report (AwER), which is used in a Short Packet (SPa), if there is an error when receiving a command. See the section “4.1.3.2.2.2 Acknowledge with Error Report (AwER)”.

The information contained herein is the exclusive property of ILI Technology Corp. and shall not be distributed, reproduced, or disclosed in whole or in part without prior written permission of ILI Technology Corp.

2. Information of the received command, which can be a Short Packet (SPa) or a Long Packet (LPa).

4.1.3.2.1.6. Null Packet, No Data (NP-L)

“Null Packet, No Data” (NP-L), which is defined in Data Type (DT, 001001b), is always used in a Long Packet (LPa) from the MCU to the display module. The purpose of this command is to keep data lanes in the high speed mode (HSMT) if necessary. The display module can ignore the Packet Data (PD) that the MCU sends.

A Long Packet (LPa) with 5 random data bytes of the Packet Data (PD) is defined as:

- Data Identification (DI)
 - ✧ Virtual Channel (VC, DI [7...6]): 00b
 - ✧ Data Type (DT, DI [5...0]): 00 1001b
- Word Count (WC)
 - ✧ Word Count (WC): 0005hex
- Error Correction Code (ECC)
- Packet Data (PD):
 - ✧ Data 0: 89hex (Random data)
 - ✧ Data 1: 23hex (Random data)
 - ✧ Data 2: 12hex (Random data)
 - ✧ Data 3: A2hex (Random data)
 - ✧ Data 4: E2hex (Random data)
- Packet Footer (PF)

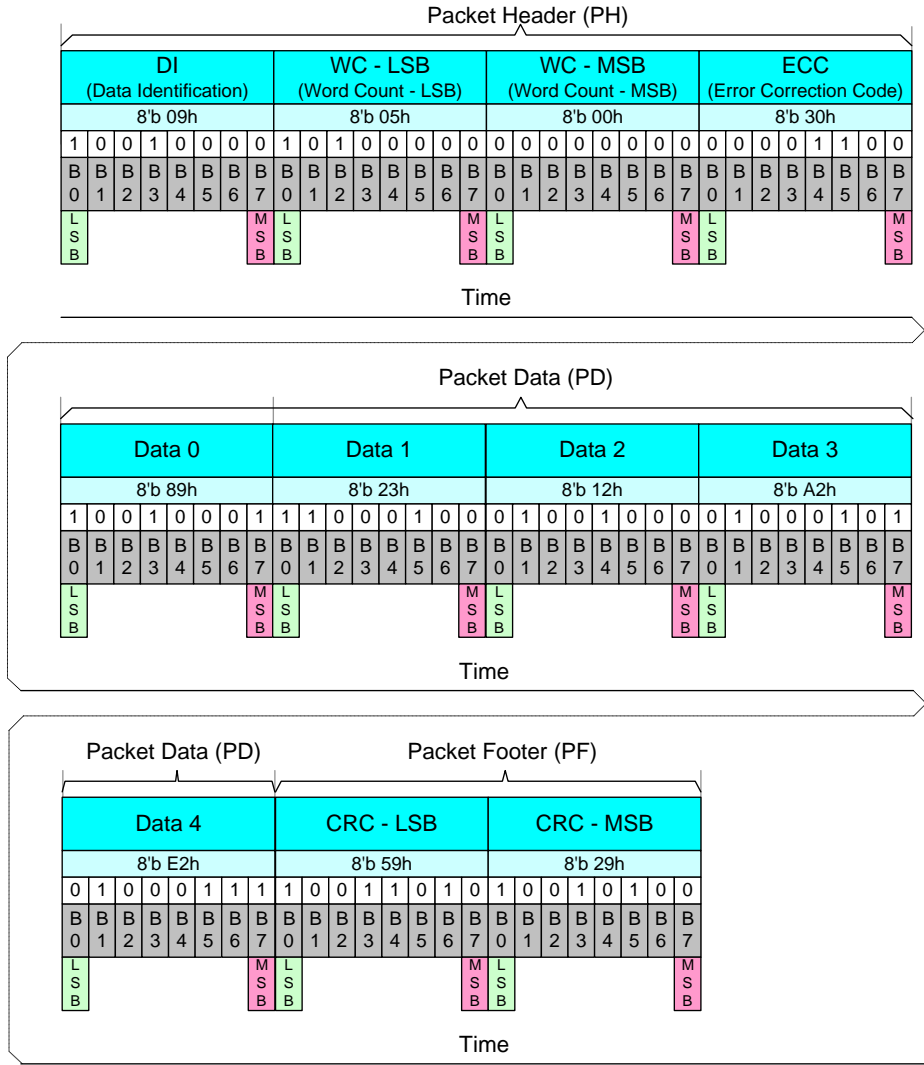

Figure 64: Null Packet, No Data (NP-L) - Example

4.1.3.2.1.7. End of Transmission Packet (EoTP)

“End of Transmission Packet” (EoTP), which is an interface level function and defined in Data Type (DT, 00 1000b), is always used in a Short Packet (SPa) from the MCU to the display module. The purpose of this command is to terminate the high Speed Data Transmission (HSDT) mode properly when EoTP is added after the last payload packet before “End of Transmission” (EoT).

The MCU can decide if it wants to use the “End of Transmission Packet” (EoTP) or not. The display shall have the capability to support both. That is, if the MCU applies the EoTP, it shall report the “DSI Protocol Violation Error” when the EoTP is not detected in the High-Speed (HS). The display module error reporting shall be enabled/disabled statistically, according to the module application.

The display module does or does not receive “End of Transmission Packet” (EoTP) from the MCU during the Low Power Data Transmission (LPDT) mode before “Mark-1” (= leaving the Escape mode) which ends the Low Power Data Transmission (LPDT) mode. The display module is not allowed to send “End of Transmission Packet” (EoTP) to the MCU during the Low Power Data Transmission (LPDT) mode. The summary of the receiving and transmitting EoTP is listed below.

Table 14: Receiving and Transmitting EoTP during LPDT

Direction	Display Module (DM) in High Speed Data Transmission (HSDT)	Display Module (DM) in Low Power Data Transmission (LPDT)
MCU => Display Module	Support With and Without EoTP	Support With and Without EoTP
Display Module => MCU	HS Mode is not available (EoTP is not available)	EoTP cannot be sent by the Display Module (DM)

A Short Packet (SPa) using a fixed format is as follows:

- Data Identification (DI)
 - ✧ Virtual Channel (VC, DI [7...6]): 00b
 - ✧ Data Type (DT, DI [5...0]): 00 1000b
- Packet Data (PD)
 - ✧ Data 0: 0Fhex
 - ✧ Data 1: 0Fhex
- Error Correction Code (ECC)
 - ✧ ECC: 01hex

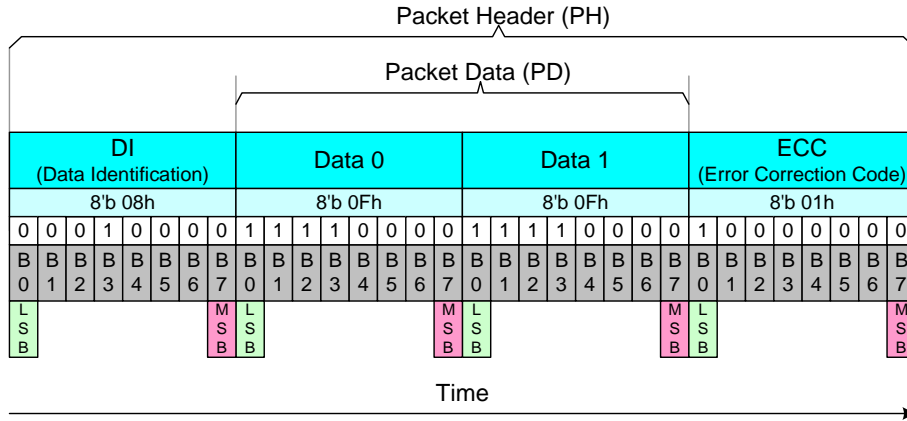

Figure 65: End of Transmission Packet (EoTP)

Some examples of the “End of Transmission Packet” (EoTP) are illustrated for reference purposes below.

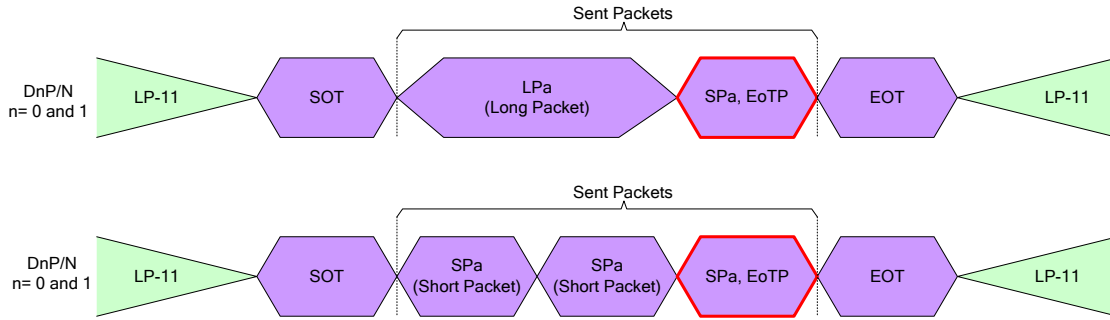

Figure 66: End of Transmission Packet (EoTP)-Examples

4.1.3.2.2. Packet from the Display Module to the MCU

4.1.3.2.2.1. Used Packet types

The display module always uses Short Packets (SPa) or Longs Packet (LPa) when returning information to the MCU after the MCU has requested information from the Display Module. This information can be a response of the Display Command Set (DCS) (See the section “4.1.3.2.1.5 Display Command Set (DCS) Read, No Parameter (DCSRN-S)”) or an Acknowledge with Error Report (See the section “4.1.3.2.2.2 Acknowledge with Error Report (AwER)”).

The used packet type is defined on Data Type (DT). See the section “4.1.3.1.3.1.2 Data Type (DT)”. If the maximum size of the Packet Data (PD) could be sent in one packet, the display module should not send returned bytes in several packets. Both cases are illustrated for reference purposes below.

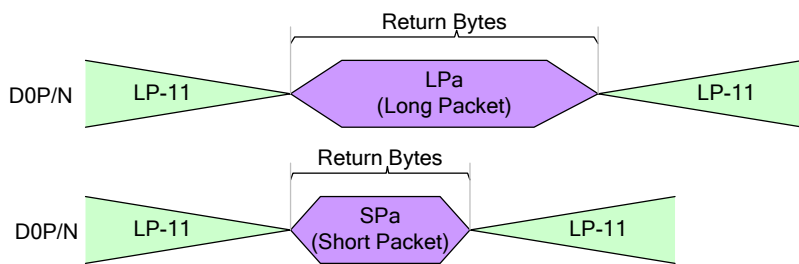

Figure 67: Return Bytes in Single Packet

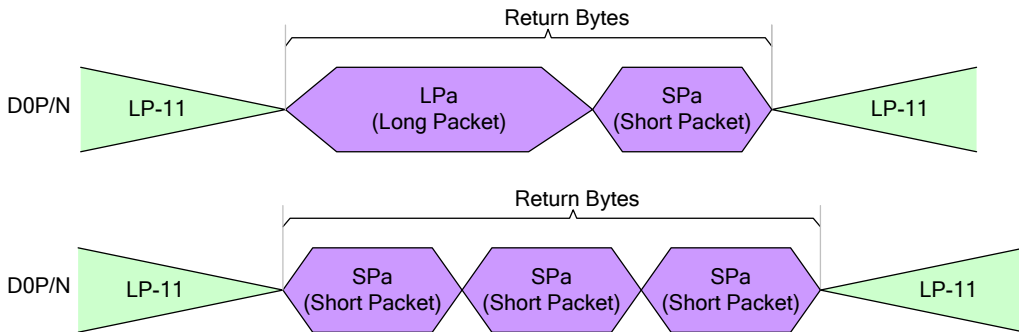

Figure 68: Return Bytes in Several Packets – Not Allowed

EXCEPTION:

The display module will return 2 packets (1st packet: Data, 2nd Packet: Acknowledge with Error Report) to the MCU when the display module receives a read command (See section “4.1.3.2.1.5 Display Command Set (DCS) Read, No Parameter (DCSRN-S)”), which is detected and corrected a single bit error by the EEC (See bit 8 in Table 15). These returned packets are illustrated for reference purposes below.

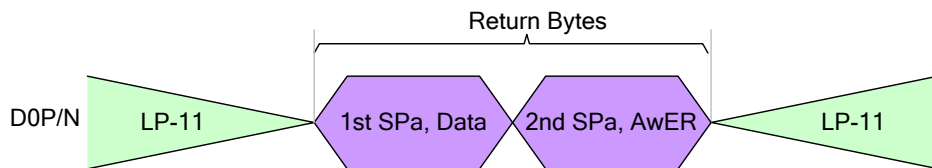

Figure 69: Exception when Returned Bytes in Several Packets

AwER = Acknowledge with Error Report

4.1.3.2.2.2. Acknowledge with Error Report (AwER)

“Acknowledge with Error Report” (AwER), which is defined in Data Type (DT, 00 0010b), is always used in a Short Packet (SPa) from the display module to the MCU. The Packet Data (PD) can include bits, which define the current error, when the corresponding bit is set to 1, as defined in the following table.

Table 15: Error Report (AwER) Bit Definitions

Bit	Description
0	SoT Error
1	SoT Sync Error
2	EoT Sync Error
3	Escape Mode Entry Command Error
4	Low-Power Transmit Sync Error
5	Any Protocol Timer Time-Out
6	False Control Error
7	Contention is Detected on the Display Module
8	ECC Error, single-bit (detected and corrected)
9	ECC Error, multi-bit (detected, not corrected)
10	Checksum Error (Long Packet only)
11	DSI Data Type (DT) Not Recognized
12	DSI Virtual Channel (VC) ID Invalid
13	Invalid Transmission Length
14	Reserved, Set to 0 internally
15	DSI Protocol Violation

These errors are included in all packages that have been received from the MCU to the display module before the Bus Turnaround (BTA). The display module ignores the received packet which includes error or errors.

Acknowledge with Error Report (AwER) of a Short Packet (SPa) is defined as:

- Data Identification (DI)
 - ✧ Virtual Channel (VC, DI [7...6]): 00b
 - ✧ Data Type (DT, DI [5...0]): 00 0010b
- Packet Data (PD)
 - ✧ Bit 8: ECC Error, single-bit (detected and corrected)
 - ✧ AwER: 0100h
- Error Correction Code (ECC)

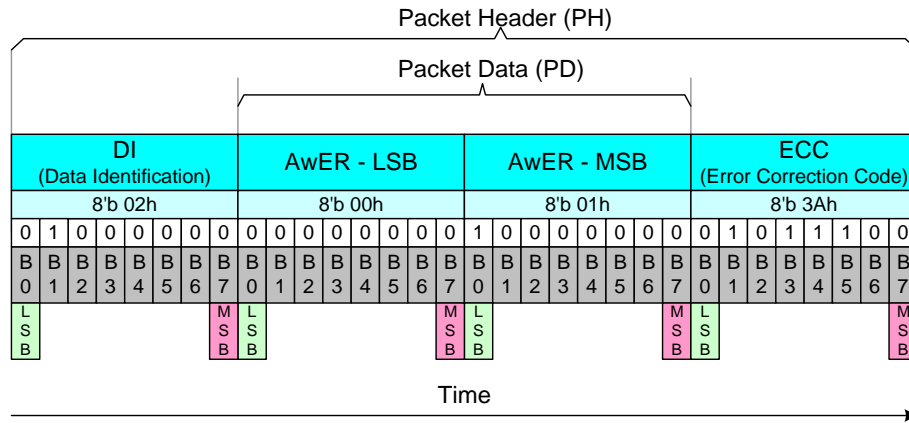

Figure 70: Acknowledge with Error Report (AwER) – Example

It is possible that the display module receives several packets, which include errors, from the MCU before the MCU performs the Bus Turnaround (BTA). Some examples are illustrated for reference purposes below.

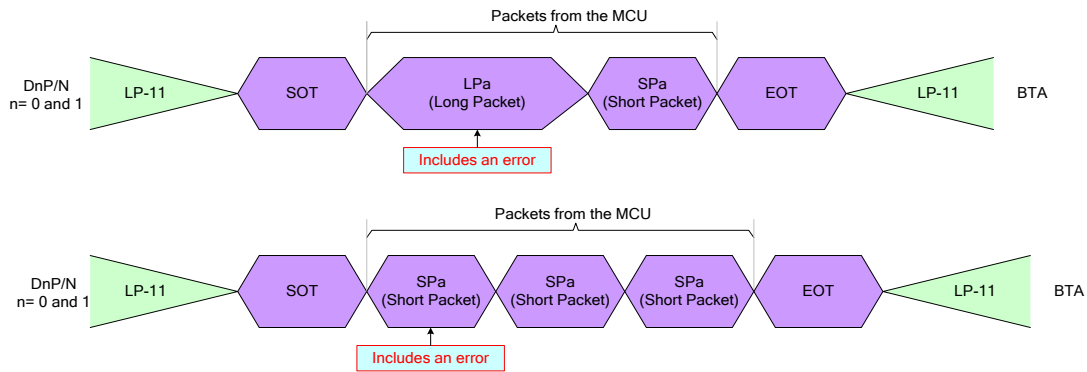

Figure 71: Errors Packets

Therefore, a method is needed to check if there are errors in the previous packets. These errors of the previous packets can be detected by “Read Display Signal Mode (0Eh)” and “Read Number of the Errors on DSI (05h)” commands. The bit D0 of the “Read Display Signal LPa Mode (0Eh)” command will be set to 1 if a received packet includes an error.

The amount of packets, which include an **ECC** or **CRC** error, is calculated in the RDNUMED register, which can read “Read Number of the Errors on DSI (05h)” command. This command also sets the RDNUMED register to 00h and set the bit D0 of the “Read Display Signal Mode (0Eh)” command to 0 after the MCU has read the RDNUMED register from the display module. The functionality of the RDNUMED register is illustrated for reference purposes below.

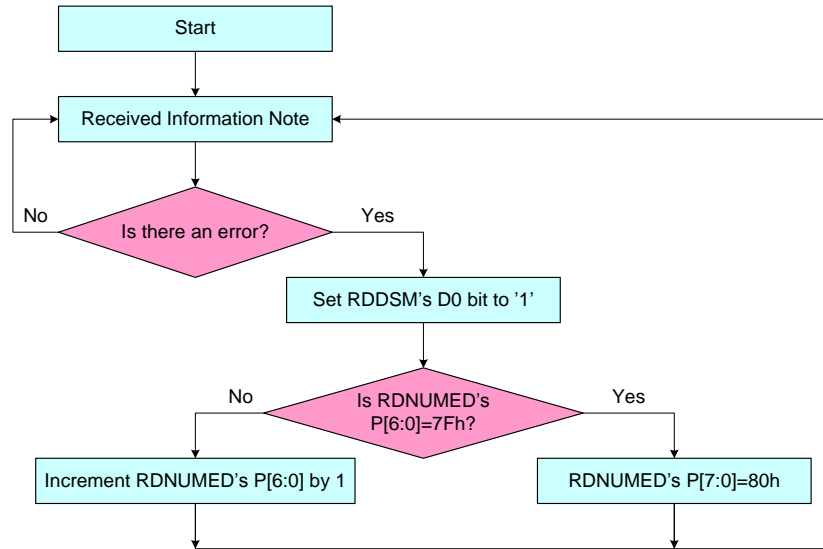

Figure 72: Flow Chart for Errors on DSI

Notes:

1. This information can be Interface or Packet Level Communication, but it is always from the MCU to the display module.
2. CRC or ECC error

4.1.3.2.2.3. DCS Read Long Response (DCSRR-L)

“DCS Read Long Response” (DCSRR-L), which is defined in Data Type (DT, 011100b), is always used in a Long Packet (LPa) from the display module to the MCU. “DCS Read Long Response” (DCSRR-L) is used when the display module wants to respond to a DCS Read command, which the MCU has sent to the display module.

A Long Packet (LPa), which includes 5 data bytes of the Packet Data (PD), is defined as:

- Data Identification (DI)
 - ✧ Virtual Channel (VC, DI [7...6]): 00b
 - ✧ Data Type (DT, DI [5...0]): 01 1100b
- Word Count (WC)
 - ✧ Word Count (WC): 0005hex
- Error Correction Code (ECC)
- Packet Data (PD):
 - ✧ Data 0: 89hex
 - ✧ Data 1: 23hex
 - ✧ Data 2: 12hex
 - ✧ Data 3: A2hex
 - ✧ Data 4: E2hex
- Packet Footer (PF)

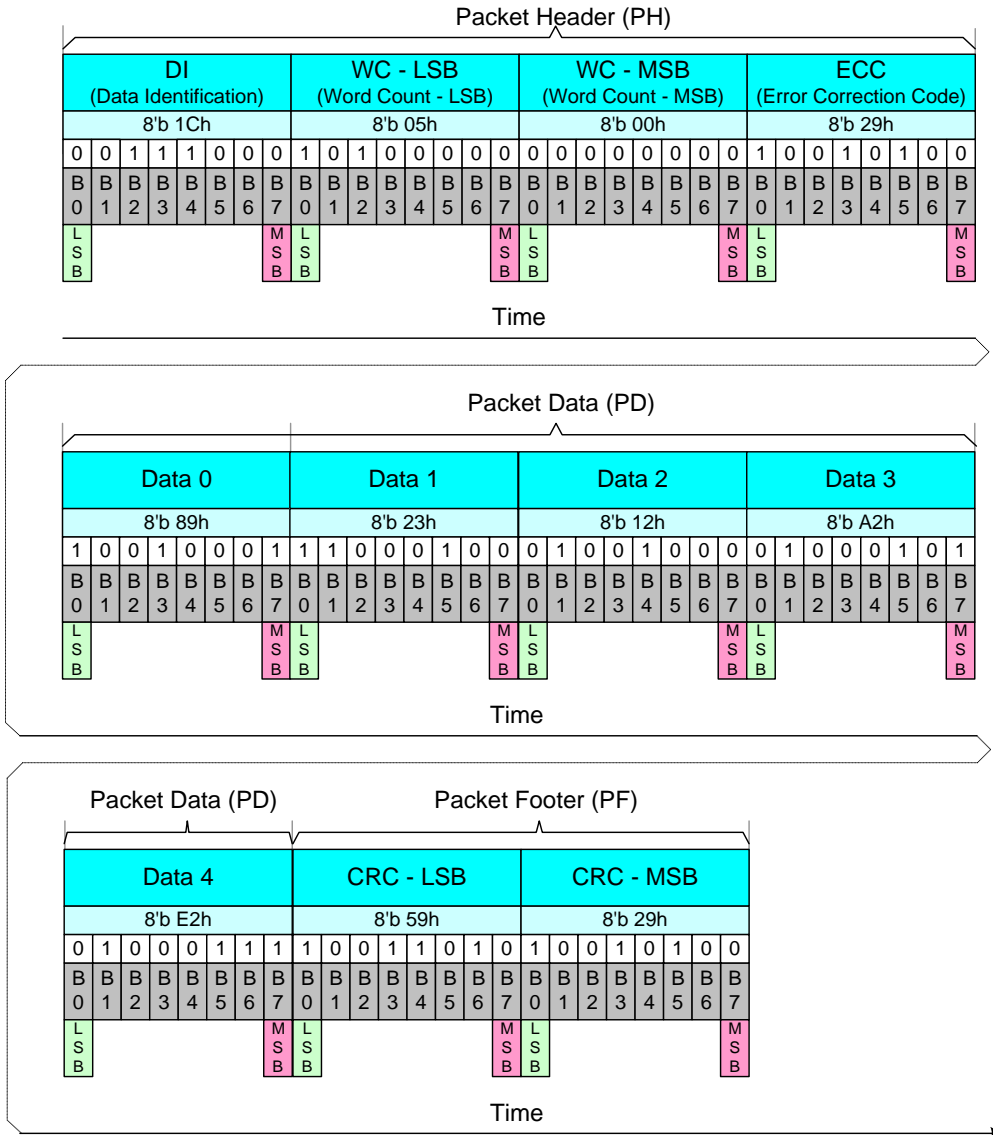

Figure 73: DCS Read Long Response (DCSRR-L) - Example

4.1.3.2.2.5. DCS Read Short Response, 2 Bytes Returned (DCSRR2-S)

“DCS Read Short Response, 2 Bytes Returned” (DCSRR2-S), which is defined in Data Type (DT, 10 0010b), is always used in a Short Packet (SPa) from the display module to the MCU. “DCS Read Short Response, 2 Bytes Returned” (DCSRR2-S) is used when the display module wants to respond to a DCS Read command, which the MCU has sent to the display module.

A Short Packet (SPa) is defined as:

- Data Identification (DI)
 - ✧ Virtual Channel (VC, DI [7...6]): 00b
 - ✧ Data Type (DT, DI [5...0]): 10 0010b
- Packet Data (PD)
 - ✧ Data 0: 45hex
 - ✧ Data 1: 32hex
- Error Correction Code (ECC)

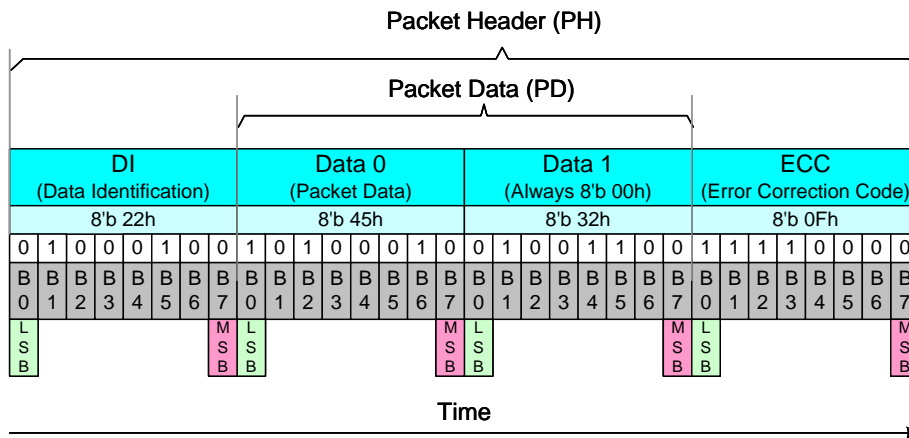

Figure 75: DCS Read Short Response, 2 Bytes Returned (DCSRR2-S) - Example

4.1.3.3. Communication Sequences

4.1.3.3.1. General

The communication sequences can be done on interface or packet levels between the MCU and the display module. See sections “4.1.2 Interface Level Communication” and “4.1.3 Packet Level Communication”. This communication sequence description is for DSI data lanes (D3P/N, D2P/N, D1P/N and D0P/N), and it is assumed that the needed low level communication is done on DSI Clock lane (CLKP/N) automatically. See the section “4.1.2.2 DSI CLK Lanes”. Functions of the interface level communication are described in the following table.

Table 16: Interface Level Communication

Interface Mode	Abbreviation	Interface Action Description
Low Power	LP-11	Stop State
	LPDT	Low Power Data Transmission
	ULPS	Ultra-Low Power State
	RAR	Remote Application Reset
	ACK	Acknowledge (No Error)
	BTA	Bus Turnaround
High Speed	HSDT	High speed Data Transmission

Functions of the packet level communication are described in the following table.

Table 17: Packet Level Communication for MCU-sourced Packets

Interface Mode	Abbreviation	Packet Size	Interface Action Description
MCU	VSS	Short Packet	Sync Event, V Sync Start
	VSE	Short Packet	Sync Event, V Sync End
	HSS	Short Packet	Sync Event, H Sync Start
	HSE	Short Packet	Sync Event, H Sync End
	EoTP	Short Packet	End of Transmission Packet (EoTP) ^{Note1}
	CMOFF	Short Packet	Color Mode Off Command
	CMON	Short Packet	Color Mode On Command
	SDNP	Short Packet	Shut Down Peripheral Command
	TONP	Short Packet	Turn On Peripheral Command
	GENWN-S	Short Packet	Generic Short WRITE, no parameters
	GENW1-S	Short Packet	Generic Short WRITE, 1 parameters
	GENW2-S	Short Packet	Generic Short WRITE, 2 parameters
	GENRN-S	Short Packet	Generic Short READ, no parameters
	GENR1-S	Short Packet	Generic Short READ, 1 parameters
	GENR2-S	Short Packet	Generic Short READ, 2 parameters
	DCSWN-S	Short Packet	DCS Write, No Parameter
	DCSW1-S	Short Packet	DCS Write, 1 Parameter
	DCSRN-S	Short Packet	DCS Read, No Parameter
	SMRPS-S	Short Packet	Set Maximum Return Packet Size
	NP-L	Long Packet	Null Packet, No Data, ^{Note2}
	BLK-L	Long Packet	Blanking Packet, no data
	GENW-L	Long Packet	Generic Long Write
	DCSW-L	Long Packet	DCS Write Long
	PKPS16	Long Packet	Packed Pixel Stream, 16-bit RGB, 5-6-5 Format
	PKPS18	Long Packet	Packed Pixel Stream, 18-bit RGB, 6-6-6 Format
	LPKPS18	Long Packet	Loosely Packed Pixel Stream, 18-bit RGB, 6-6-6 Format
	PKPS24	Long Packet	Packed Pixel Stream, 24-bit RGB, 8-8-8 Format

Table 18: Packet Level Communication for Peripheral-sourced packets

Interface Mode	Abbreviation	Packet Size	Interface Action Description
Display Module (ILI9881C-0D)	AwER	Short Packet	Acknowledge with Error Report
	EoTP	Short Packet	End of Transmission Packet
	GENRR1-S	Short Packet	Generic Short READ Response, 1 byte returned
	GENRR2-S	Short Packet	Generic Short READ Response, 2 byte returned
	GENRR-L	Long Packet	Generic Long READ Response
	DCSRR-L	Long Packet	DCS Read Long Response
	DCSRR1-S	Short Packet	DCS Read Short Response, 1 byte returned
	DCSRR2-S	Short Packet	DCS Read Short Response, 2 byte returned

4.1.3.3.2. Sequences

4.1.3.3.2.1. DCS Write, 1 Parameter Sequence

A Short Packet (SPa) of “Display Command Set (DCS) Write, 1 Parameter (DCSW1-S)” is defined in the section “4.1.3.2.1.3 Display Command Set (DCS) Write, 1 Parameter (DCSW1-S)” and example sequences on how this packet is used are described in following tables.

Table 19: DCS Write, 1 Parameter Sequence – Example 1

DCS Write, 1 Parameter Sequence – Example 1						
Line	MCU		Information Direction	Display Module (ILI9881C-0D)		Comment
	Packet Sender	Interface Mode Control		Interface Mode Control	Packet Sender	
1	--	LP-11	→	--	--	Start
2	DCSW1-S	LPDT	→	--	--	
3	--	LP-11	→	--	--	End

Table 20: DCS Write, 1 Parameter Sequence – Example 2

DCS Write, 1 Parameter Sequence – Example 2						
Line	MCU		Information Direction	Display Module (ILI9881C-0D)		Comment
	Packet Sender	Interface Mode Control		Interface Mode Control	Packet Sender	
1	--	LP-11	→	--	--	Start
2	DCSW1-S	HSDT	→	--	--	
3	EoTP	HSDT	→	--	--	End of Transmission Packet
4	--	LP-11	→	--	--	End

Table 21: DCS Write, 1 Parameter Sequence – Example 3

DCS Write, 1 Parameter Sequence – Example 3						
Line	MCU		Information Direction	Display Module (ILI9881C-0D)		Comment
	Packet Sender	Interface Mode Control		Interface Mode Control	Packet Sender	
1	--	LP-11	→	--	--	Start
2	DCSW1-S	HSDT	→	--	--	
3	EoTP	HSDT	→	--	--	End of Transmission Packet
4	--	LP-11	→	--	--	
5	--	BTA	↔	BTA	--	Interface Control Change from MCU to the display module
6	--	--	←	LP-11	--	If No Error → Go to Line 8 If Error Occurs → Go to Line 13
7						
8	--	--	←	ACK	--	No Error
9	--	--	←	LP-11	--	
10	--	BTA	↔	BTA	--	Interface Control Change from the display module to MCU
11	--	LP-11	→	--	--	End
12						
13	--	--	←	LPDT	AwER	Error Report
14	--	--	←	LP-11	--	
15	--	BTA	↔	BTA	--	
16	--	LP-11	→	--	--	End

4.1.3.3.2.2. DCS Write, No Parameter Sequence

A Short Packet (SPa) of “Display Command Set (DCS) Write, No Parameter (DCSWN-S)” is defined in the section “4.1.3.2.1.2 Display Command Set (DCS) Write, No Parameter (DCSWN-S)” and example sequences on how this packet is used are described in following tables.

Table 22: DCS Write, No Parameter Sequence – Example 1

DCS Write, No Parameter Sequence – Example 1						
Line	MCU		Information Direction	Display Module (ILI9881C-0D)		Comment
	Packet Sender	Interface Mode Control		Interface Mode Control	Packet Sender	
1	--	LP-11	→	--	--	Start
2	DCSWN-S	LPDT	→	--	--	
3	--	LP-11	→	--	--	End

Table 23: DCS Write, No Parameter Sequence – Example 2

DCS Write, No Parameter Sequence – Example 2						
Line	MCU		Information Direction	Display Module (ILI9881C-0D)		Comment
	Packet Sender	Interface Mode Control		Interface Mode Control	Packet Sender	
1	--	LP-11	→	--	--	Start
2	DCSWN-S	HSDT	→	--	--	
3	EoTP	HSDT	→	--	--	End of Transmission Packet
4	--	LP-11	→	--	--	End

Table 24: DCS Write, No Parameter Sequence – Example 3

DCS Write, 1 Parameter Sequence – Example 3						
Line	MCU		Information Direction	Display Module (ILI9881C-0D)		Comment
	Packet Sender	Interface Mode Control		Interface Mode Control	Packet Sender	
1	--	LP-11	→	--	--	Start
2	DCSWN-S	HSDT	→	--	--	
3	EoTP	HSDT	→	--	--	End of Transmission Packet
4	--	LP-11	→	--	--	
5	--	BTA	↔	BTA	--	Interface Control Change from MCU to the display module
6	--	--	←	LP-11	--	If No Error → Go to Line 8 If Error Occurs → Go to Line 13
7						
8	--	--	←	ACK	--	No Error
9	--	--	←	LP-11	--	
10	--	BTA	↔	BTA	--	Interface Control Change from the display module to MCU
11	--	LP-11	→	--	--	End
12						
13	--	--	←	LPDT	AwER	Error Report
14	--	--	←	LP-11	--	
15	--	BTA	↔	BTA	--	
16	--	LP-11	→	--	--	End

4.1.3.3.2.3. DCS Write Long Sequence

A Long Packet (LPa) of “Display Command Set (DCS) Write Long (DCSW-L)” is defined in the section “4.1.3.2.1.4 Display Command Set (DCS) Write Long (DCSW-L)” and example sequences on how this packet is used are described in following tables.

Table 25: DCS Write Long Sequence – Example 1

DCS Write Long Sequence – Example 1						
Line	MCU		Information Direction	Display Module (ILI9881C-0D)		Comment
	Packet Sender	Interface Mode Control		Interface Mode Control	Packet Sender	
1	--	LP-11	→	--	--	Start
2	DCSW-L	LPDT	→	--	--	
3	--	LP-11	→	--	--	End

Table 26: DCS Write Long Sequence – Example 2

DCS Write Long Sequence – Example 2						
Line	MCU		Information Direction	Display Module (ILI9881C-0D)		Comment
	Packet Sender	Interface Mode Control		Interface Mode Control	Packet Sender	
1	--	LP-11	→	--	--	Start
2	DCSW-L	HSDT	→	--	--	
3	EoTP	HSDT	→	--	--	End of Transmission Packet
4	--	LP-11	→	--	--	End

Table 27: DCS Write Long Sequence – Example 3

DCS Write Long Sequence – Example 3						
Line	MCU		Information Direction	Display Module (ILI9881C-0D)		Comment
	Packet Sender	Interface Mode Control		Interface Mode Control	Packet Sender	
1	--	LP-11	→	--	--	Start
2	DCSW-L	HSDT	→	--	--	
3	EoTP	HSDT	→	--	--	End of Transmission Packet
4	--	LP-11	→	--	--	
5	--	BTA	↔	BTA	--	Interface Control Change from MCU to the display module
6	--	--	←	LP-11	--	If No Error → Go to Line 8 If Error Occurs → Go to Line 13
7						
8	--	--	←	ACK	--	No Error
9	--	--	←	LP-11	--	
10	--	BTA	↔	BTA	--	Interface Control Change from the display module to MCU
11	--	LP-11	→	--	--	End
12						
13	--	--	←	LPDT	AwER	Error Report
14	--	--	←	LP-11	--	
15	--	BTA	↔	BTA	--	
16	--	LP-11	→	--	--	End

4.1.3.3.2.4. DCS Read, No Parameter Sequence

A Short Packet (SPa) of “Display Command Set (DCS) Read, No Parameter (DCSRN-S)” is defined in the section “4.1.3.2.1.5 Display Command Set (DCS) Read, No Parameter (DCSRN-S)” and example sequences on how this packet is used are described in following tables.

Table 28: DCS Read, No Parameter Sequence – Example 1

DCS Read, No Parameter Sequence – Example 1						
Line	MCU		Information Direction	Display Module (ILI9881C-0D)		Comment
	Packet Sender	Interface Mode Control		Interface Mode Control	Packet Sender	
1	--	LP-11	→	--	--	Start
2	SMRPS-S	HSDT	→	--	--	Defined how many data byte is wanted to read : 1 byte
3	DCSRN-S	HSDT	→	--	--	Wanted to get a response ID1 (DAh)
4	EoTP	HSDT	→	--	--	End of Transmission Packet
5	--	LP-11	→	--	--	
6	--	BTA	↔	BTA	--	Interface Control Change from MCU to the display module
7	--	--	←	LP-11	--	If No Error → Go to Line 9 If Error Occurs → Go to Line 14 If Error is Corrected by ECC → Go to Line 19
8						
9	--	--	←	LPDT	DCSRR1-S	Response 1 byte return
10	--	--	←	LP-11	--	
11	--	BTA	↔	BTA	--	Interface Control Change from the display module to MCU
12	--	LP-11	→	--	--	End
13						
14	--	--	←	LPDT	AwER	Error Report
15	--	--	←	LP-11	--	
16	--	BTA	↔	BTA	--	Interface Control Change from the display module to MCU
17	--	LP-11	→	--	--	End
18						
19	--	--	←	LPDT	DCSRR1-S	Response 1 byte return
20	--	--	←	LPDT	AwER	Error Report (Error is corrected by ECC)
21			←	LP-11	--	
22	--	BTA	↔	BTA	--	Interface Control Change from the display module to MCU
23	--	LP-11	→	--	--	End

Table 29: DCS Read, No Parameter Sequence – Example 2

DCS Read, No Parameter Sequence – Example 2						
Line	MCU		Information Direction	Display Module (ILI9881C-0D)		Comment
	Packet Sender	Interface Mode Control		Interface Mode Control	Packet Sender	
1	--	LP-11	➔	--	--	Start
2	SMRPS-S	HSDT	➔	--	--	Defined how many data byte is wanted to read : 200 bytes
3	DCSRN-S	HSDT	➔	--	--	Wanted to get a response
4	EoTP	HSDT	➔	--	--	End of Transmission Packet
5	--	LP-11	➔	--	--	
6	--	BTA	↔	BTA	--	Interface Control Change from MCU to the display module
7	--	--	←	LP-11	--	If No Error ➔ Go to Line 9 If Error Occurs ➔ Go to Line 14 If Error is Corrected by ECC ➔ Go to Line 19
8						
9	--	--	←	LPDT	DCSRR-L	Response 200 byte return
10	--	--	←	LP-11	--	
11	--	BTA	↔	BTA	--	Interface Control Change from the display module to MCU
12	--	LP-11	➔	--	--	End
13						
14	--	--	←	LPDT	AwER	Error Report
15	--	--	←	LP-11	--	
16	--	BTA	↔	BTA	--	Interface Control Change from the display module to MCU
17	--	LP-11	➔	--	--	End
18						
19	--	--	←	LPDT	DCSRR-S	Response 200 byte return
20	--	--	←	LPDT	AwER	Error Report (Error is corrected by ECC)
21			←	LP-11	--	
22	--	BTA	↔	BTA	--	Interface Control Change from the display module to MCU
23	--	LP-11	➔	--	--	End

4.1.3.3.2.5. Null Packet, No Data Sequence

A Long Packet (LPa) of “Null Packet, No Data (NP-L)” is defined in the section “4.1.3.2.1.6 Null Packet, No Data (NP-L)”, and an example sequence on how this packet is used is described in the following table.

Table 30: Null Packet, No Data Sequence - Example

Null Packet, No Data Sequence – Example						
Line	MCU		Information Direction	Display Module (ILI9881C-0D)		Comment
	Packet Sender	Interface Mode Control		Interface Mode Control	Packet Sender	
1	--	LP-11	➔	--	--	Start
2	NP-L	HSDT	➔	--	--	Only High Speed Data Transmission is used
3	EoTP	HSDT	➔	--	--	End of Transmission Packet
4	--	LP-11	➔	--	--	End

4.1.3.3.2.6. End of Transmission Packet

A Short Packet (SPa) of “End of Transmission (EoTP)” is defined in the section “4.1.3.2.1.7 End of Transmission Packet (EoTP)”, and an example sequence on how this packet is used is described in the following table.

Table 31: End of Transmission Packet – Example

End of Transmission Packet – Example						
Line	MCU		Information Direction	Display Module (ILI9881C-0D)		Comment
	Packet Sender	Interface Mode Control		Interface Mode Control	Packet Sender	
1	--	LP-11	➔	--	--	Start
2	NP-L	HSDT	➔	--	--	Only High Speed Data Transmission is used
3	EoTP	HSDT	➔	--	--	End of Transmission Packet
4	--	LP-11	➔	--	--	End

4.1.3.4. 16 bit / pixel Writing

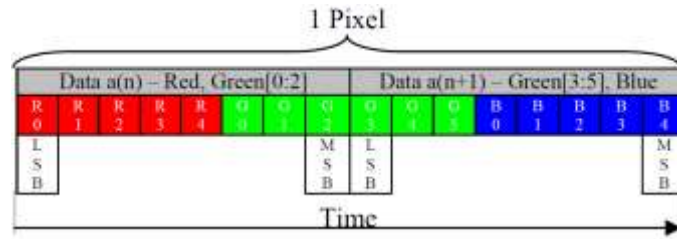

Figure 76: One Pixel Bit and Write Color Orders

The MCU can send to the display module a following packet.

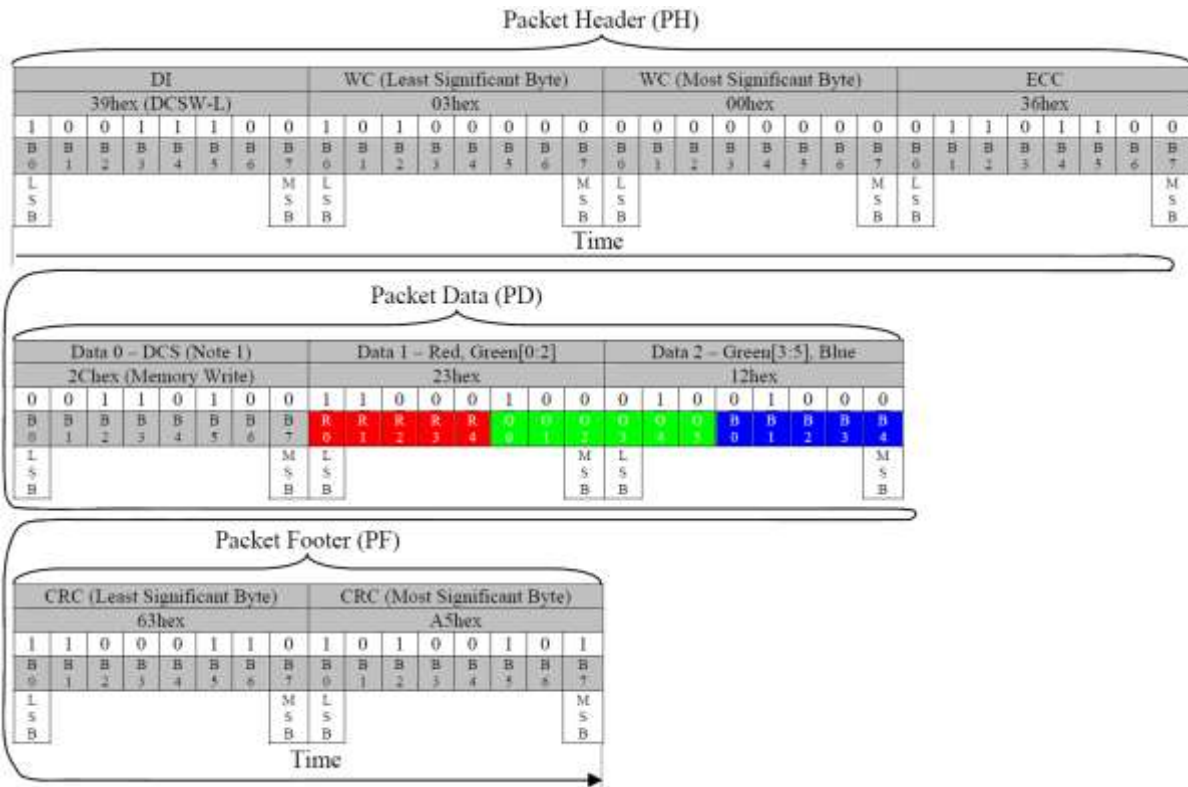

Figure 77: One Pixel Write (DCSW-L) – Example 1

Notes:

1. Memory Write (2Ch) or Memory Write Continue (3Ch)
2. It is possible that one pixel information is split in one different packets which are ending and starting as follows:
RG – GB (2 packets)
3. Packet can include several pixels (Not only one pixel as in this example)

4.1.3.5. 24 bit/pixel Writing

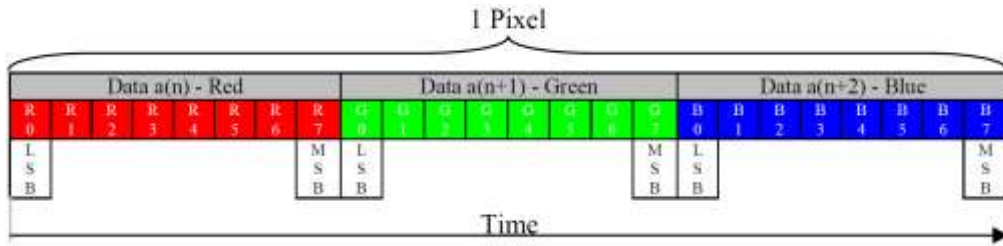

Figure 80: One Pixel Bit and Color Write Orders

The MCU can send to the display module a following packet.

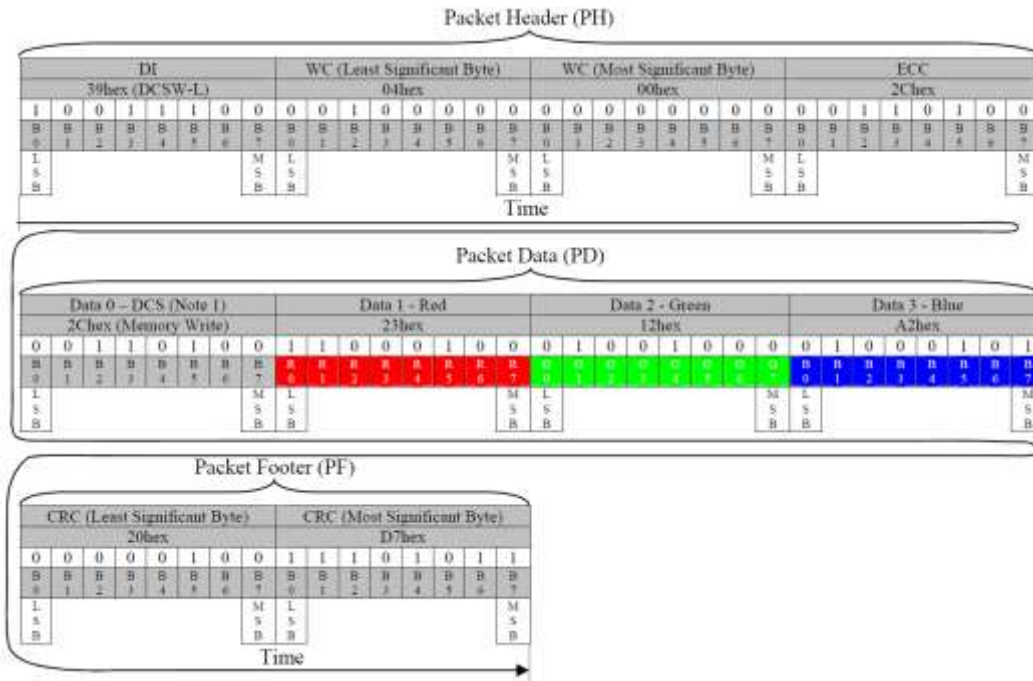

Figure 81: One Pixel Write (DCSW-L) – Example

Notes:

1. Memory Write (2Ch) or Memory Write Continue (3Ch)
2. It is possible that one pixel information is split in two or three different packets which are ending and starting as follows:
 - R – GB (2 packets)
 - RG – B (2 packets)
 - R – G – B (3 packets)
3. Packet can include several pixels (Not only one pixel as in this example)

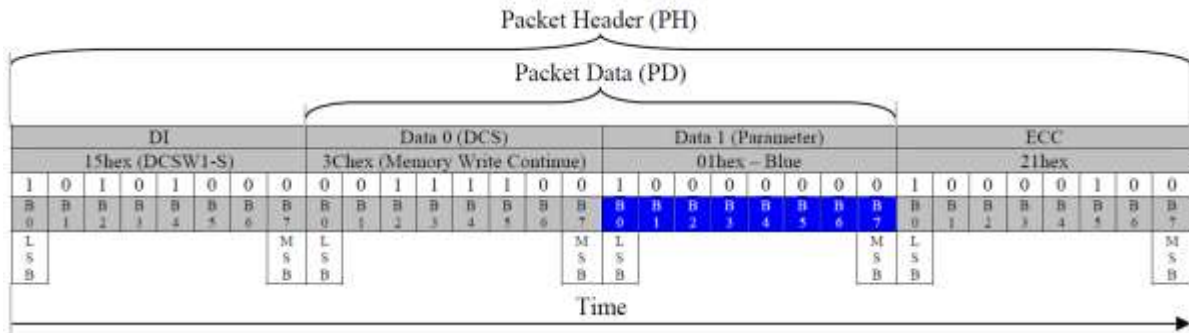

Figure 82: Blue Subpixel Write (DCSW1-S) – Example 2

Notes:

1. DCS (Data 0) cannot be “Memory Write” (2Ch) command. It must always be “Memory Write Continue” (3Ch)
2. Previous data byte was G[0:7]



Figure 83: Green Subpixel Write (DCSW1-S) – Example 3

Notes:

1. DCS (Data 0) cannot be “Memory Write” (2Ch) command. It must always be “Memory Write Continue” (3Ch)
2. Previous data byte was R[0:7]

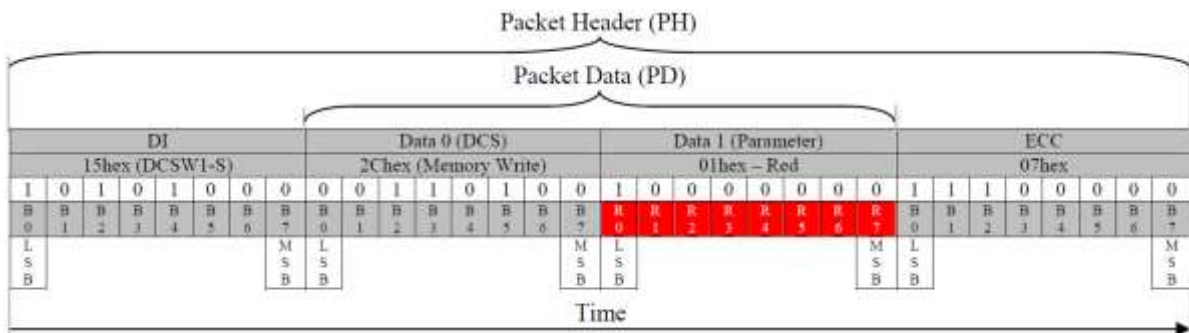

Figure 84: Red Subpixel Write (DCSW1-S) – Example 4

Notes:

1. DCS (Data 0) can also be “Memory Write Continue” (3Ch) command
2. Previous data byte was B[0:7]

4.2. Display Data Format

4.2.1. DSI Transmission Data Format

4.2.1.1. 16-bit per Pixel, Long Packet, Data Type 00 1110 (0Eh)

Packed Pixel Stream 16-Bit Format is a Long Packet used to transmit image data formatted as 16-bit pixels to a Video Mode display module. The packet consists of the DI byte, a two-byte WC, an ECC byte, a payload of length WC bytes and a two-byte checksum. Pixel format is red (5 bits), green (6 bits), and blue (5 bits), in that order. Note that the Green component is split across two bytes. Within a color component, the LSB is sent first, the MSB last. With this format, pixel boundaries align with byte boundaries every two bytes. The total line width (displayed plus non-displayed pixels) should be a multiple of two bytes.

Normally, the ILI9881C-0D has no frame buffer of its own, so all image data shall be supplied by the host processor at a sufficiently high rate to avoid flicker or other visible artifact.

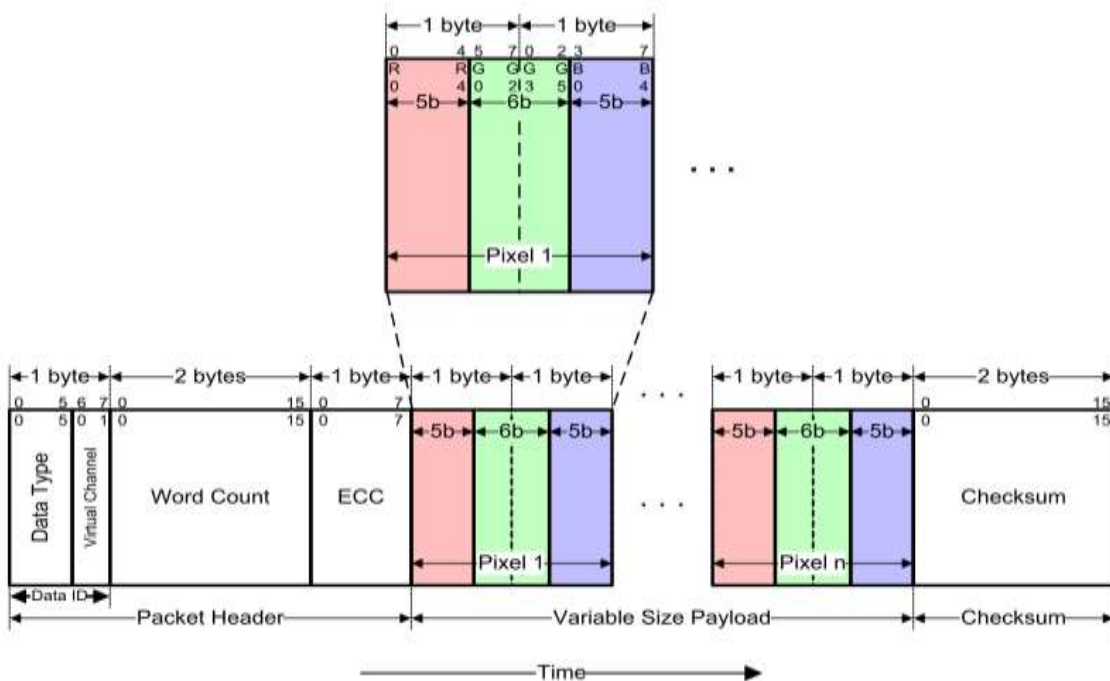

Figure 85: 16-bit per Pixel, Data Type 00 1110 (0Eh)

4.2.1.2. 18-bit per Pixel, Long Packet, Data Type = 01 1110 (1Eh)

Packed Pixel Stream 18-Bit Format (Packed) is a Long packet. It is used to transmit RGB image data formatted as pixels to a Video Mode display module that displays 18-bit pixels. The packet consists of the DI byte, a two-byte WC, an ECC byte, a payload of length WC bytes, and a two-byte Checksum. Pixel format is red (6 bits), green (6 bits) and blue (6 bits), in that order. Within a color component, the LSB is sent first, the MSB last.

Note that pixel boundaries only align with byte boundaries every four pixels (nine bytes). Preferably, display modules employing this format have a horizontal extent (width in pixels) evenly divisible by four, so no partial bytes remain at the end of the display line data. If the active (displayed) horizontal width is not a multiple of four pixels, the transmitter shall send additional filled pixels at the end of the display line to make the transmitted width a

The information contained herein is the exclusive property of ILI Technology Corp. and shall not be distributed, reproduced, or disclosed in whole or in part without prior written permission of ILI Technology Corp.

multiple of four pixels. The receiving peripheral shall not display the filled pixels when refreshing the display device. For example, if a display device has an active display width of 399 pixels, the transmitter should send 400 pixels in one or more packets. The receiver should display the first 399 pixels and discard the last pixel of the transmission. With this format, the total line width (displayed and non-displayed pixels) should be a multiple of four pixels (nine bytes).

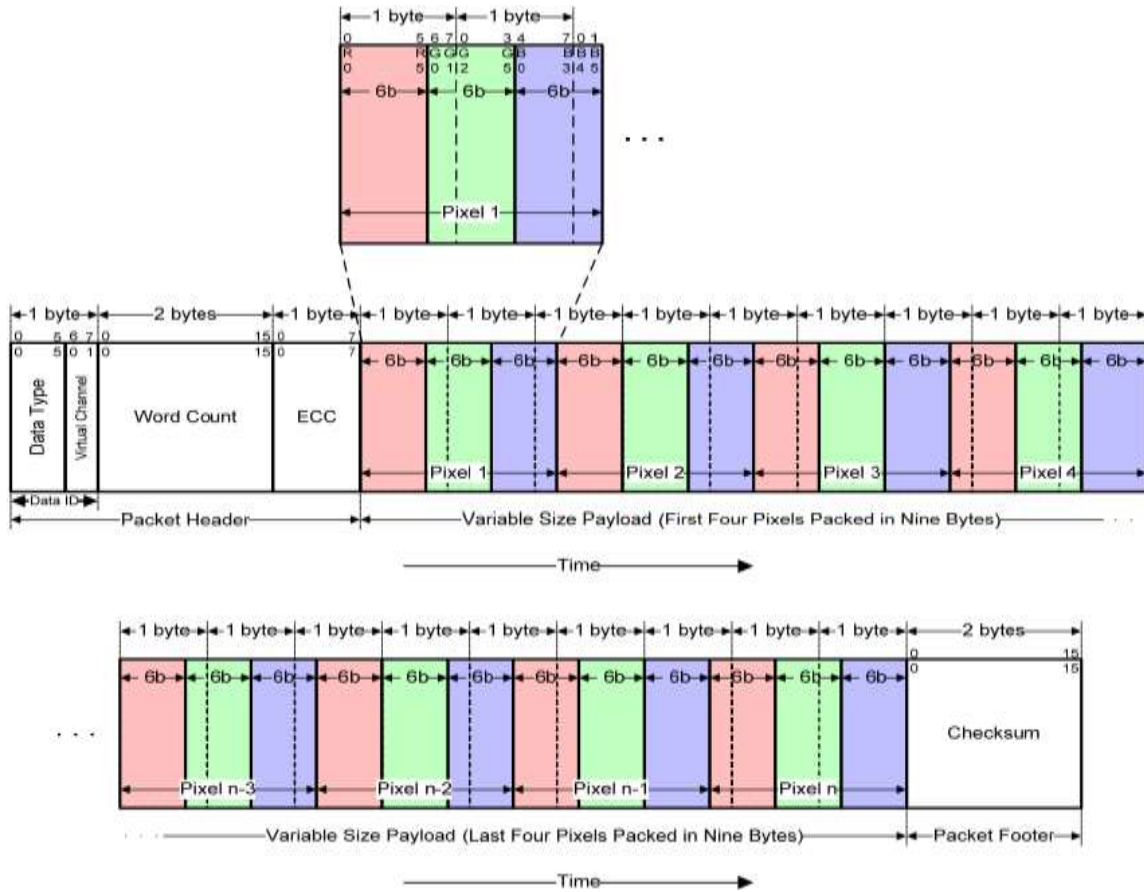

Figure 86: 18-bit per Pixel, Data Type = 01 1110 (1Eh)

4.2.1.3. 18-bit per Pixel, Long Packet, Data Type = 10 1110 (2Eh)

In the 18-bit Pixel Loosely Packed format, each R, G, or B color component is six bits but is shifted to the upper bits of the byte, such that the valid pixel bits occupy bits [7:2] of each byte. Bits [1:0] of each payload byte representing active pixels are ignored. As a result, each pixel requires three bytes as it is transmitted across the link. This requires more bandwidth than the “packed” format, but requires less shifting and multiplexing logic in the packing and unpacking functions on each end of the Link.

This format is used to transmit RGB image data formatted as pixels to a Video Mode display module that displays 18-bit pixels. The packet consists of the DI byte, a two-byte WC, an ECC byte, a payload of length WC bytes and a two-byte Checksum. The pixel format is red (6 bits), green (6 bits) and blue (6 bits) in that order. Within a color component, the LSB is sent first, the MSB last.

With this format, pixel boundaries align with byte boundaries every three bytes. The total line width (displayed and non-displayed pixels) should be a multiple of three bytes.

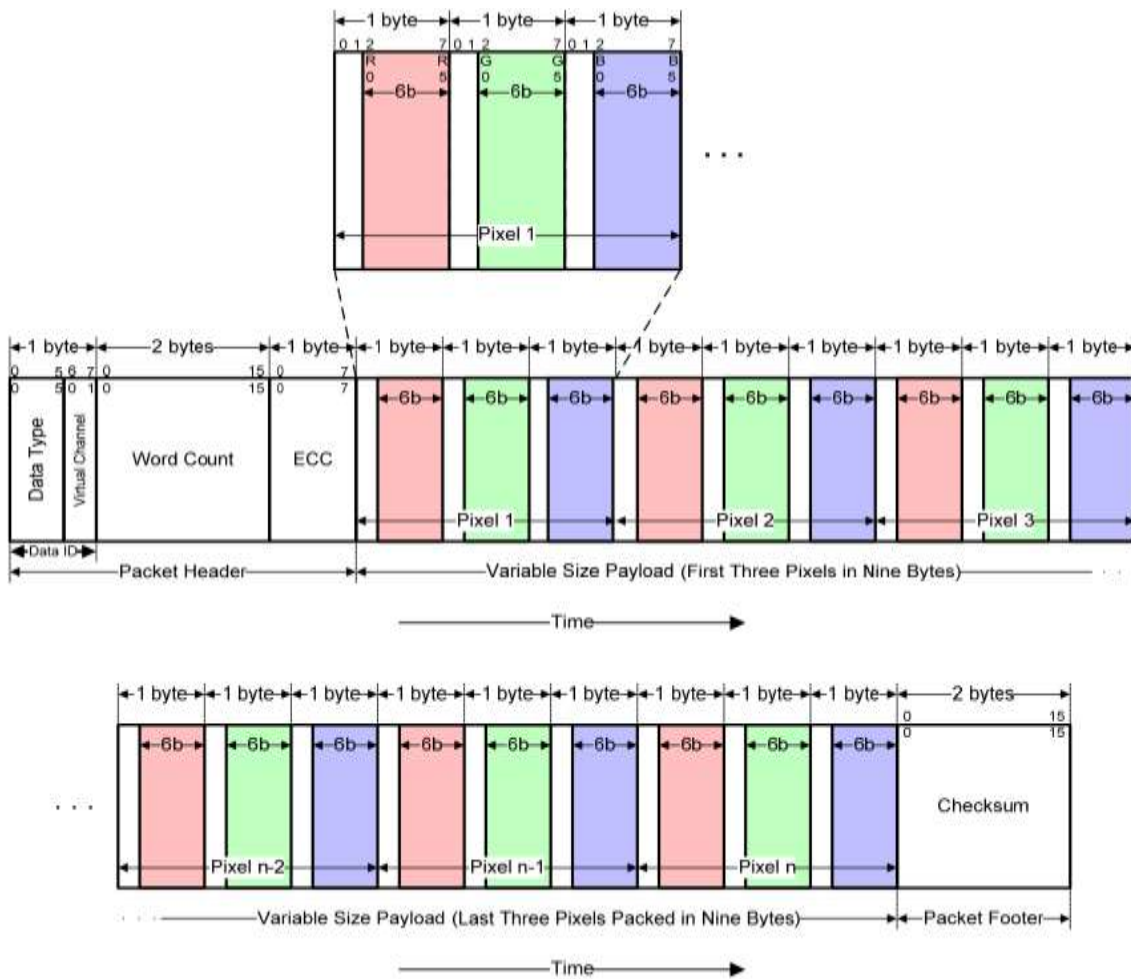

Figure 87: 18-bit per Pixel, Data Type = 10 1110 (2Eh)

4.2.1.4. 24-bit per Pixel, Long Packet, Data Type = 11 1110 (3Eh)

Packed Pixel Stream 24-Bit Format is a Long packet. It is used to transmit image data formatted as 24-bit pixels to a Video Mode display module. The packet consists of the DI byte, a two-byte WC, an ECC byte, a payload of length WC bytes and a two-byte Checksum. The pixel format is red (8 bits), green (8 bits) and blue (8 bits), in that order. Each color component occupies one byte in the pixel stream; no components are split across byte boundaries. Within a color component, the LSB is sent first, the MSB last.

With this format, pixel boundaries align with byte boundaries every three bytes. The total line width (displayed and non-displayed pixels) should be a multiple of three bytes.

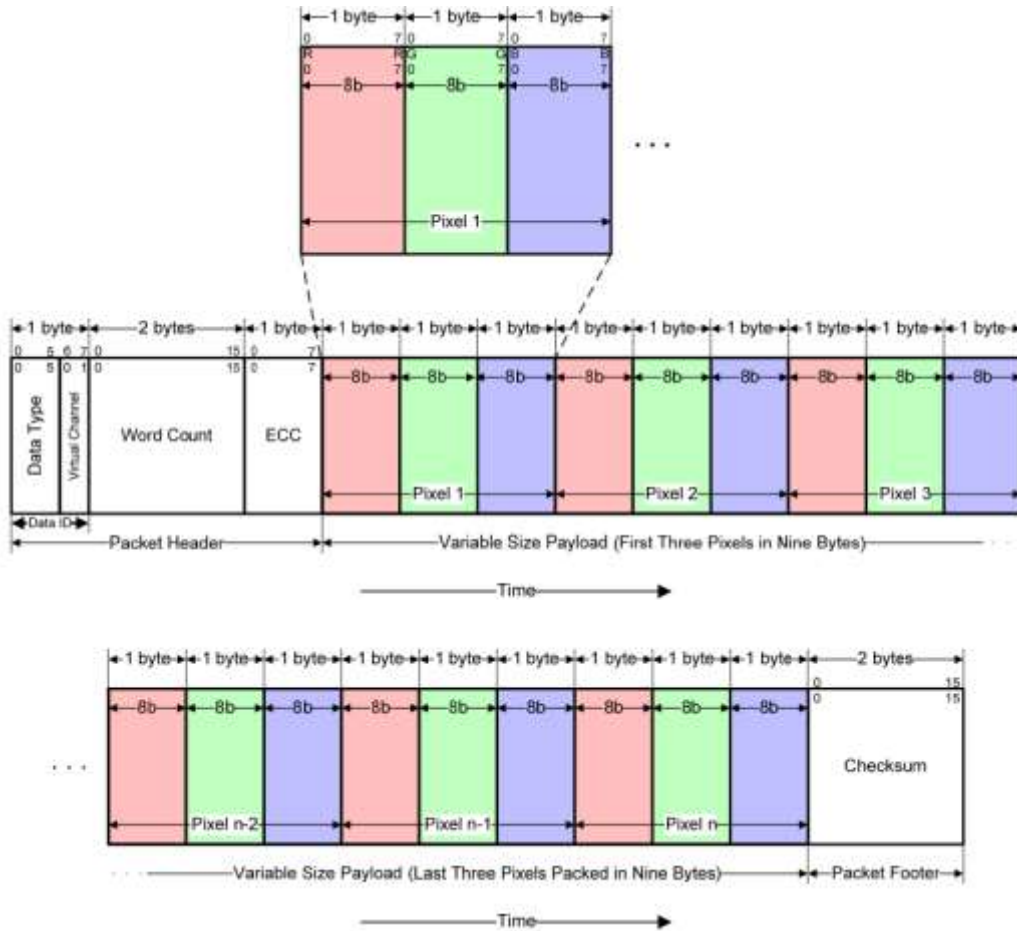

Figure 88: 24-bit per Pixel, Data Type = 11 1110 (3Eh)

4.2.2. 16/18-bit Color Data Mapping to 24-bit Pixel Data Operation

Table 32 below lists settings for 24-bit data mapping. Set the EPF[1:0] bits function, which defines three types of data formats for 24-bit data (pixel data r, g, b) mapping.

Table 32: 16/18-bit Color Data Mapping to 24-bit Pixel Data Operation

EPF[1:0]	Expand 16-bit color data (R,G,B) to 24-bit subpixel data (r, g, b)	Expand 18-bit color data (R,G,B) to 24-bit subpixel data (r, g, b)
00	0 is written to the LSB. 8 bits subpixel, data r [7:0] = {16-bit color data R [4:0], 3'h0} 8 bits subpixel, data g [7:0] = {16-bit color data G [5:0], 2'h0} 8 bits subpixel, data b [7:0] = {16-bit color data B [4:0], 3'h0} (Note3): that the data are converted as follows. 16-bit color data R [4:0] = 5'h1F, G [5:0] = 6'h3F, B [4:0] = 5'h1F → 24-bit pixel data r, g, b [7:0] = 24'hFFFFFF	0 is written to the LSB. 8 bits subpixel, data r [7:0] = {18-bit color data R [5:0], 2'h0} 8 bits subpixel, data g [7:0] = {18-bit color data G [5:0], 2'h0} 8 bits subpixel, data b [7:0] = {18-bit color data B [5:0], 2'h0} (Note1): that the data are converted as follows. 18-bit color data R [5:0] = 6'h3F, G [5:0] = 6'h3F, B [5:0] = 6'h3F → 24-bit pixel data r, g, b [7:0] = 24'hFFFFFF
01	1 is written to the LSB. 8 bits subpixel, data r [7:0] = {16-bit color data R [4:0], 3'h7} 8 bits subpixel, data g [7:0] = {16-bit color data G [5:0], 2'h3} 8 bits subpixel, data b [7:0] = {16-bit color data B [4:0], 3'h7} (Note4): that the data are converted as follows. 16-bit color data R [4:0] = 5'h0, G [5:0] = 6'h0, B [4:0] = 5'h0 →24-bit pixel data r, g, b [7:0] = 24'h000000	1 is written to the LSB. 8 bits subpixel, data r [7:0] = {18-bit color data R [5:0], 2'h3} 8 bits subpixel, data g [7:0] = {18-bit color data G [5:0], 2'h3} 8 bits subpixel, data b [7:0] = {18-bit color data B [5:0], 2'h3} (Note2): that the data are converted as follows. 18-bit color data R [5:0] = 6'h0, G [5:0] = 6'h0, B [5:0] = 6'h0 →24-bit pixel data r, g, b [7:0] = 24'h000000
10	The MSB value is written to the LSB. 8 bits subpixel, data r [7:0] = {16-bit color data R [4:0], R [4:2]} 8 bits subpixel, data g [7:0] = {16-bit color data G [5:0], G [5:4]} 8 bits subpixel, data b [7:0] = {16-bit color data B [4:0], B [4:2]}	The MSB value is written to the LSB. 8 bits subpixel, data r [7:0] = {18-bit color data R [5:0], R [5:4]} 8 bits subpixel, data g [7:0] = {18-bit color data G [5:0], G [5:4]} 8 bits subpixel, data b [7:0] = {18-bit color data B [5:0], B [5:4]}
11	Same as setting "EPF [1:0] = 10"	Same as setting "EPF [1:0] = 10"

	Display image data (24 bits)																							
	R7	R6	R5	R4	R3	R2	R1	R0	G7	G6	G5	G4	G3	G2	G1	G0	B7	B6	B5	B4	B3	B2	B1	B0
24-bit	R[7]	R[6]	R[5]	R[4]	R[3]	R[2]	R[1]	R[0]	G[7]	G[6]	G[5]	G[4]	G[3]	G[2]	G[1]	G[0]	B[7]	B[6]	B[5]	B[4]	B[3]	B[2]	B[1]	B[0]
18-bit EPF[1:0]=00 (Note 1)	R[5]	R[4]	R[3]	R[2]	R[1]	R[0]	0	0	G[5]	G[4]	G[3]	G[2]	G[1]	G[0]	0	0	B[5]	B[4]	B[3]	B[2]	B[1]	B[0]	0	0
18-bit EPF[1:0]=01 (Note 2)	R[5]	R[4]	R[3]	R[2]	R[1]	R[0]	1	1	G[5]	G[4]	G[3]	G[2]	G[1]	G[0]	1	1	B[5]	B[4]	B[3]	B[2]	B[1]	B[0]	1	1
18-bit EPF[1:0]=10	R[5]	R[4]	R[3]	R[2]	R[1]	R[0]	R[5]	R[4]	G[5]	G[4]	G[3]	G[2]	G[1]	G[0]	G[5]	G[4]	B[5]	B[4]	B[3]	B[2]	B[1]	B[0]	B[5]	B[4]
16-bit EPF[1:0]=00 (Note 3)	R[4]	R[3]	R[2]	R[1]	R[0]	0	0	0	G[5]	G[4]	G[3]	G[2]	G[1]	G[0]	0	0	B[4]	B[3]	B[2]	B[1]	B[0]	0	0	0
16-bit EPF[1:0]=01 (Note 4)	R[4]	R[3]	R[2]	R[1]	R[0]	1	1	1	G[5]	G[4]	G[3]	G[2]	G[1]	G[0]	1	1	B[4]	B[3]	B[2]	B[1]	B[0]	1	1	1
16-bit EPF[1:0]=10	R[4]	R[3]	R[2]	R[1]	R[0]	R[4]	R[3]	R[2]	G[5]	G[4]	G[3]	G[2]	G[1]	G[0]	G[5]	G[4]	B[4]	B[3]	B[2]	B[1]	B[0]	B[4]	B[3]	B[2]

Example 1: 16-bit data mapping to 24-bit, EPF[1:0] = 10

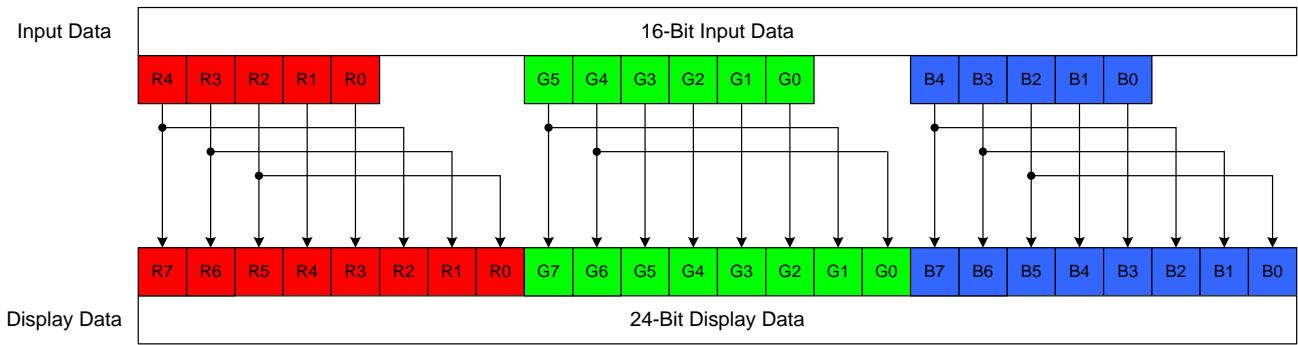

Figure 89: EPF[1:0] = 10, 16-bit Data Mapping to 24-bit

Example 2: 18-bit data mapping to 24-bit, EPF[1:0] = 10

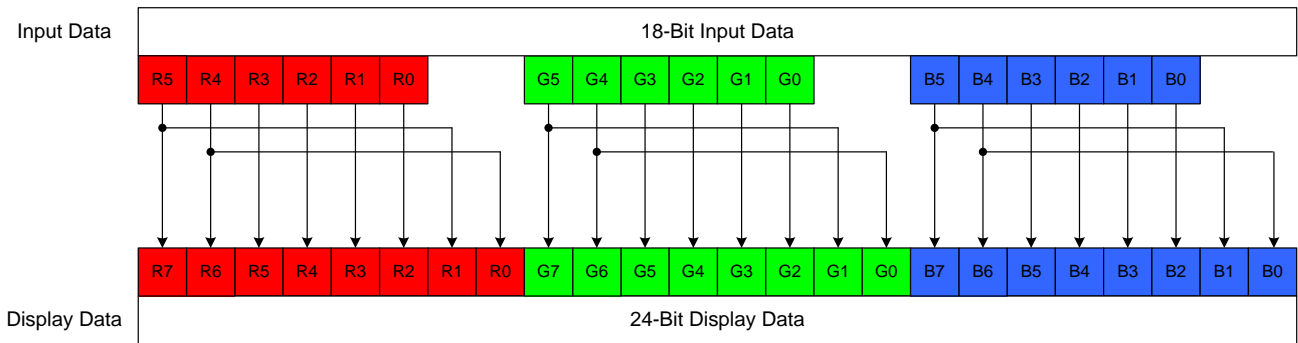

Figure 90: EPF[1:0] = 10, 18-bit Data Mapping to 24-bit

5. Command

5.1. Command Flow

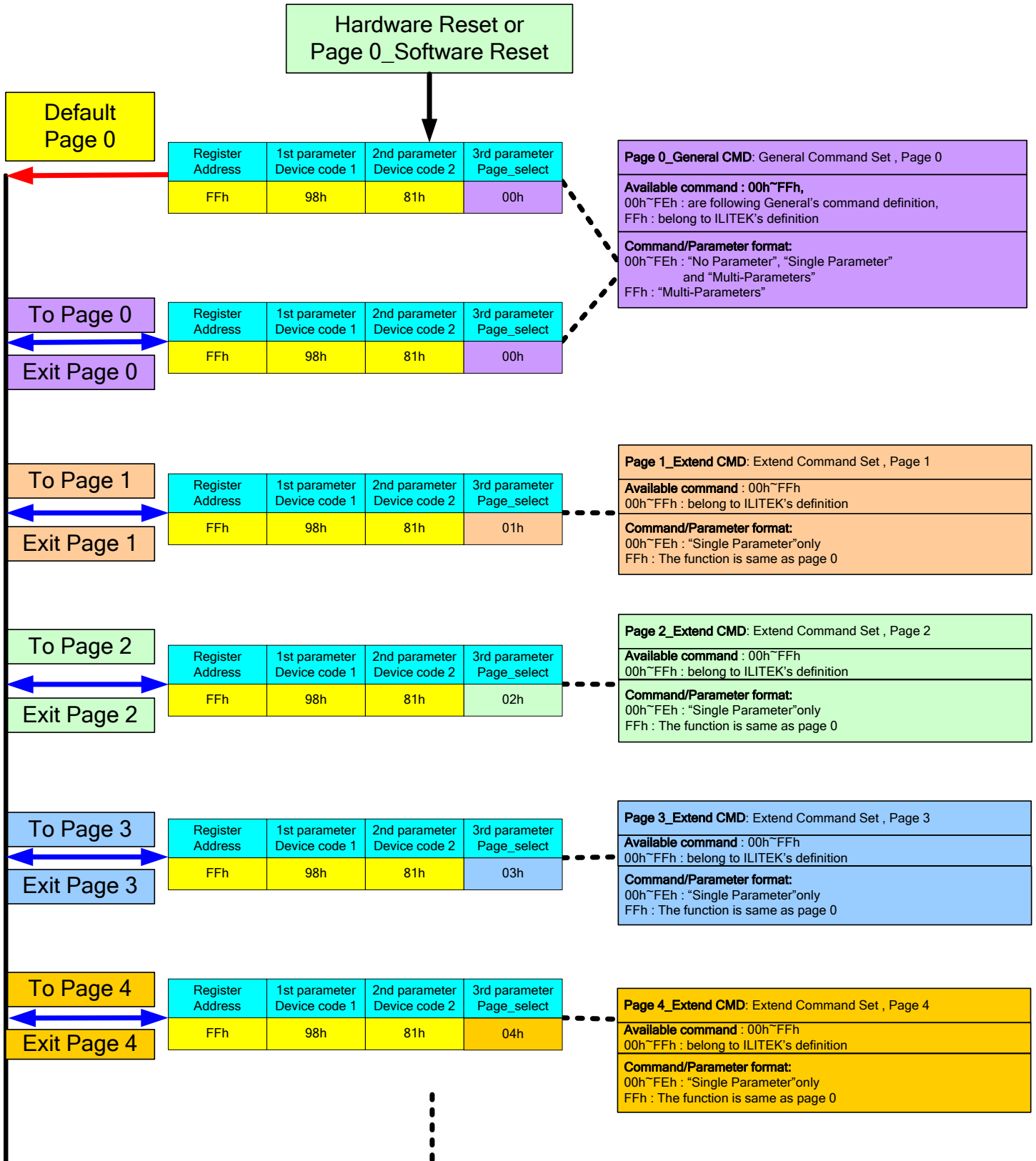

Figure 91: Command Flow

5.2. Command List

5.2.1. Page 0 Command Set

Command			W/R	Function	D7	D6	D5	D4	D3	D2	D1	D0	Default (hex)	MTP (times)
Page	Address	Parameter												
P0	00h	-	W	NOP	No Argument								-	-
P0	01h	-	W	Software Reset	No Argument								-	-
P0	05h	1st	R	Read Number of the Errors on DSI	P[7:0]								00h	-
P0	09h	1st	R	Read Display Status	D31	0	0	0	0	D26	0	D24	00h	-
		2nd	R		D23	0	0	0	D19	0	D17	D16	01h	-
		3rd	R		0	0	0	D12	D11	D10	D9	D8	00h	-
		4th	R		D7	D6	D5	0	0	0	0	D0	00h	-
P0	0Ah	1st	R	Read Display Power Mode	D7	D6	0	D4	D3	D2	0	0	08h	-
P0	0Bh	1st	R	Read Display MADCTL	0	0	0	0	D3	0	D1	D0	00h	-
P0	0Ch	1st	R	Read Pixel Format	0	0	0	0	0	D2	D1	D0	07h	-
P0	0Dh	1st	R	Read Display Mode	0	0	0	D4	D3	D2	D1	D0	00h	-
P0	0Eh	1st	R	Read Display signal Mode	D7	D6	0	0	0	0	0	D0	00h	-
P0	0Fh	1st	R	Read Display Self-Diagnostic Result	D7	D6	0	0	0	0	0	D0	00h	-
P0	10h	-	W	Sleep In	No Argument								-	-
P0	11h	-	W	Sleep Out	No Argument								-	-
P0	13h	-	W	Normal Display Mode On	No Argument								-	-
P0	22h	-	W	All Pixel Off	No Argument								-	-
P0	23h	-	W	All Pixel On	No Argument								-	-
P0	26h	1st	W	Gamma Curve Set	0	0	0	0	GC[3:0]			01h	-	
P0	28h	-	W	Display Off	No Argument								-	-
P0	29h	-	W	Display ON	No Argument								-	-
P0	2Ch	Nth	W	Memory Write	-								-	-
P0	34h	-	W	TE OFF	No Argument								-	-
P0	35h	1st	W	TE ON	0	0	0	0	0	0	0	M	00h	-
P0	36h	1st	W	Memory Access	0	0	0	0	BGR	0	SS	GS	00h	-
P0	38h	-	W	Idle Mode Off	No Argument								-	-
P0	39h	-	W	Idle Mode On	No Argument								-	-
P0	3Ah	1st	W	Interface Pixel Format	0	0	0	0	0	DBI[2:0]			07h	-
P0	3Ch	Nth	W	Memory Write Continue	-								-	-
P0	44h	1st	W	Set tear scan line	0	0	0	0	0	TE_LINE[10:8]			00h	-
		2nd			TE_LINE[7:0]								00h	-
P0	45h	1st	R	Get tear scan line	0	0	0	0	0	TE_LINE[10:8]			00h	-
		2nd			TE_LINE[7:0]								00h	-
P0	51h	1st	W	Write Display Brightness	0	0	0	0	DBV[11:8]			00h	-	
		2nd			DBV[7:0]								00h	-
P0	52h	1st	R	Read Display Brightness Value	0	0	0	0	DBV[11:8]			00h	-	
		2nd			DBV[7:0]								00h	-
P0	53h	1st	W	Write CTRL Display	0	0	BCTRL	0	DD	BL	0	0	00h	-
P0	54h	1st	R	Read CTRL Display	0	0	BCTRL	0	DD	BL	0	0	00h	-
P0	55h	1st	W	Write Power Save	PWRSAVE[7:0]								00h	-
P0	56h	1st	R	Read Power Save	PWRSAVE[7:0]								00h	-
P0	59h	-	W	Stop Transition	No Argument								-	-
P0	5Eh	1st	W	Write CABG Minimum Brightness	0	0	0	0	CMB[11:8]			00h	-	
		2nd			CMB[7:0]								00h	-
P0	5Fh	1st	R	Read CABG Minimum Brightness	0	0	0	0	CMB[11:8]			00h	-	
		2nd			CMB[7:0]								00h	-
P0	68h	1st	W	Set Transition Time	TT_STP[7:0]								00h	-
		2nd			ST_TIM[7:0]								00h	-
P0	69h	1st	R	Get Transition Time	TT_STP[7:0]								00h	-
		2nd			ST_TIM[7:0]								00h	-

Command			W/R	Function	D7	D6	D5	D4	D3	D2	D1	D0	Default (hex)	MTP (times)
Page	Address	Parameter												
P0	80h	1st	W	Write Idle Mode	0	0	0	0	0	R	G	B	07h	-
P0	81h	1st	R	Read Idle Mode Color	0	0	0	0	0	R	G	B	07h	-
P0	A1h	1st	R	Read the DDB from the provided location	SID[7:0]							00h	1	
		2nd			SID[15:8]							00h	1	
		3rd			MRID[7:0]							00h	1	
		4th			MRID[15:8]							00h	1	
		5th			1	1	1	1	1	1	1	FFh	-	
P0	A8h	1st	R	Continue reading the DDB from the last read location	D1[7:0]							00h	-	
		2nd			D2[7:0]							00h	-	
		:			:							00h	-	
		nth			Dn[7:0]							00h	-	
P0	AAh	1st	R	Read First Checksum	FCS[7:0]							00h	-	
P0	AFh	1st	R	Read Continue Checksum	CCS[7:0]							00h	-	
P0	DAh	1st	R	Read ID1	ID1[7:0]							00h	3	
P0	DBh	1st	R	Read ID2	ID2[6:0]							00h	3	
P0	DCh	1st	R	Read ID3	ID3[7:0]							00h	3	
P0	FFh	1st	W	EXTC Command Set Enable Register	1	0	0	1	1	0	0	0	98h	-
		2nd	W		1	0	0	0	0	0	1	81h	-	
		3rd	W		PAGE[7:0]							00h	-	

Notes:

1. Undefined commands are treated as NOP (00h) command.
2. Commands 10h, 13h, 22h, 23h, 26h, 28h, 29h, 36h, 38h, 39h, 51h, 53h, 55h, 5Eh, 68h and 80h are updated during V-SYNC when Module is in Sleep Out Mode to avoid abnormal visual effects. During Sleep In mode, these commands are updated immediately. Commands 05h, 09h, 0Ah, 0Bh, 0Ch, 0Dh, 0Eh, 0Fh, 45h, 52h, 54h, 56h, 5Fh, 69h, 81h, A1h, A8h of these commands is updated immediately both in Sleep In mode and Sleep Out mode.

5.2.2. Page 1 Command Set

Command			W/R	Function	D7	D6	D5	D4	D3	D2	D1	D0	Default (hex)	MTP (times)	
Page	Address	Parameter													
P1	00h	1st	R	Read ID4	ID4[23:16]							98h	-		
P1	01h	1st	R		ID4[15:8]							81h	-		
P1	02h	1st	R		ID4[7:0]							1Ch	-		
P1	22h	1st	W/R	Set Panel Operation Mode and Data Complement Setting	0	0	EPF[1:0]	BGR_PA NEL	REV_PA NEL	SS_PANE L	GS_PAN EL	30h	1		
P1	25h	1st	W/R	Blanking Porch Control	VFP[7:0]							14h	-		
P1	26h	1st	W/R		VBP[7:0]							14h	-		
P1	29h	1st	W/R	Touch	0	0	0	0	0	0	0	TOUCH_	00h	-	
P1	2Eh	1st	W/R	Gate Number	NL[7:0]							C8h	1		
P1	31h	1st	W/R	Display Inversion	0	0	0	0	DINV[3:0]			00h	1		
P1	34h	1st	W/R	Dithering Enable	0	0	0	0	0	0	0	DITH_EN	00h	1	
P1	40h	1st	W/R	Pump Clock Adjustment	0	EXT_CPCK_SEL[1:0]	1	0	0	VCL_CLK	VGHL_CL	33h	1		
P1	41h	1st	W/R		0	VCL_CLK_SELA[2:0]		0	VCL_CLK_SELB[2:0]		33h	1			
P1	42h	1st	W/R		0	VGHL_CLK_SELA[2:0]		0	VGHL_CLK_SELB[2:0]		44h	1			
P1	43h	1st	W/R		0	4002_RATIO_FREQA[2:0]		0	4002_RATIO_FREQB[2:0]		55h	1			
P1	50h	1st	W/R	Power Control 1	VREG1[7:0]							95h	1		
P1	51h	1st	W/R		VREG2[7:0]							95h	1		
P1	52h	1st	W/R	VCOM Control 1	0	0	0	0	0	0	0	VCM1[8]	00h	3	
P1	53h	1st	W/R		VCM1[7:0]							7Bh	3		
P1	54h	1st	W/R		0	0	0	0	0	0	0	VCM2[8]	00h	3	
P1	55h	1st	W/R		VCM2[7:0]							7Bh	3		
P1	56h	1st	W/R		0	0	0	0	0	0	0	NVM1	00h	-	
P1	58h	1st	W/R	Entry Mode Set	LVD_EN	0	0	0	0	0	0	0	0	00h	1
P1	60h	1st	W/R	Source Timing Adjust	0	0	SDT[5:0]				14h	1			
P1	61h	1st	W/R		0	0	CRT[5:0]				00h	1			
P1	62h	1st	W/R		0	0	EQT[5:0]				19h	1			
P1	63h	1st	W/R		0	0	PCT[5:0]				10h	1			
P1	A0h	1st	W/R	Positive Gamma Correction	0	0	VP0[5:0]				00h	1			
P1	A1h	1st	W/R		0	VP4[6:0]				0Dh	1				
P1	A2h	1st	W/R		0	VP8[6:0]				1Dh	1				
P1	A3h	1st	W/R		0	0	VP12[5:0]				11h	1			
P1	A4h	1st	W/R		0	0	VP16[5:0]				0Ch	1			
P1	A5h	1st	W/R		0	VP24[6:0]				23h	1				
P1	A6h	1st	W/R		0	0	VP36[5:0]				17h	1			
P1	A7h	1st	W/R		0	0	VP52[5:0]				1Ch	1			
P1	A8h	1st	W/R		VP80[7:0]				82h	1					
P1	A9h	1st	W/R		0	0	VP111[5:0]				21h	1			
P1	AAh	1st	W/R		0	0	VP144[5:0]				2Ah	1			
P1	ABh	1st	W/R		VP175[7:0]				6Bh	1					
P1	ACh	1st	W/R		0	0	VP203[5:0]				19h	1			
P1	ADh	1st	W/R		0	0	VP219[5:0]				14h	1			
P1	A Eh	1st	W/R		VP231[6:0]				45h	1					
P1	AFh	1st	W/R		0	0	VP239[5:0]				1Dh	1			
P1	B0h	1st	W/R		0	0	VP243[5:0]				23h	1			
P1	B1h	1st	W/R		VP247[6:0]				52h	1					
P1	B2h	1st	W/R		VP251[6:0]				63h	1					
P1	B3h	1st	W/R		0	0	VP255[5:0]				39h	1			
P1	B6h	1st	W/R		Pad Control	IM_SW_EN	IM_SW[2:0]		RS_SW_EN	0	RS_SW[1:0]		00h	1	
P1	B7h	1st	W/R			0	0	0	0	0	0	LANSEL_SW_EN	LANSEL_SW	00h	1

Command			W/R	Function	D7	D6	D5	D4	D3	D2	D1	D0	Default (hex)	MTP (times)
Page	Address	Parameter												
P1	C0h	1st	W/R	Negative Gamma Correction	0	0	VN0[5:0]					00h	1	
P1	C1h	1st	W/R		0	VN4[6:0]					0Dh	1		
P1	C2h	1st	W/R		0	VN8[6:0]					1Dh	1		
P1	C3h	1st	W/R		0	0	VN12[5:0]					11h	1	
P1	C4h	1st	W/R		0	0	VN16[5:0]					0Ch	1	
P1	C5h	1st	W/R		0	VN24[6:0]					23h	1		
P1	C6h	1st	W/R		0	0	VN36[5:0]					17h	1	
P1	C7h	1st	W/R		0	0	VN52[5:0]					1Ch	1	
P1	C8h	1st	W/R		VN80[7:0]					82h	1			
P1	C9h	1st	W/R		0	0	VN111[5:0]					21h	1	
P1	CAh	1st	W/R		0	0	VN144[5:0]					2Ah	1	
P1	CBh	1st	W/R		VN175[7:0]					6Bh	1			
P1	CCh	1st	W/R		0	0	VN203[5:0]					19h	1	
P1	CDh	1st	W/R		0	0	VN219[5:0]					14h	1	
P1	CEh	1st	W/R		0	VN231[6:0]					45h	1		
P1	CFh	1st	W/R		0	0	VN239[5:0]					1Dh	1	
P1	D0h	1st	W/R		0	0	VN243[5:0]					23h	1	
P1	D1h	1st	W/R		0	VN247[6:0]					52h	1		
P1	D2h	1st	W/R		0	VN251[6:0]					63h	1		
P1	D3h	1st	W/R		0	0	VN255[5:0]					39h	1	
P1	E0h	1st	W/R		NV Memory Write	PGM_DATA[7:0]					00h	-		
P1	E1h	1st	W/R			PGM_ADR[7:0]					00h	-		
P1	E2h	1st	W/R			PGM_ADR[15:8]					00h	-		
P1	E3h	1st	W/R		NV Memory Protection Key	KEY[23:16]					00h	-		
P1	E4h	1st	W/R			KEY[15:8]					00h	-		
P1	E5h	1st	W/R			KEY[7:0]					00h	-		
P1	E6h	1st	R	NV Memory Status Read	0	ID2_MK[2:0]			0	ID1_MK[2:0]			00h	-
P1	E7h	1st	R		0	0	0	0	ID3_MK[2:0]			00h	-	
P1	E8h	1st	R		GAMMA_P_MK	GAMMA_N_MK	VCM2_MK[2:0]			VCM1_MK[2:0]			00h	-
P1	E9h	1st	R		OTP_BUSY	0	0	0	0	0	0	0	00h	-
P1	F0h	1st	W/R	Time Stamp	Time_Stamp_Week[7:0]					00h	1			
P1	F1h	1st	W/R		Time_Stamp_Year[7:0]					00h	1			
P1	FFh	1st	W	EXTC Command Set Enable Register	1	0	0	1	1	0	0	0	98h	-
		2nd	W		1	0	0	0	0	0	0	1	81h	-
		3rd	W		PAGE[7:0]					01h	-			

5.2.3. Page 2 Command Set

Command			W/R	Function	D7	D6	D5	D4	D3	D2	D1	D0	Default (hex)	MTP (times)
Page	Address	Parameter												
P2	03h	1st	W/R	Dynamic Backlight Control 1	0	TT_STP_MED[2:0]		1	TT_STP_LOW[2:0]			29h	1	
P2	04h	1st	W/R		0	ST_TIM_LOW[2:0]		0	TT_STP_HIGH[2:0]			14h	1	
P2	05h	1st	W/R		0	ST_TIM_HIGH[2:0]		0	ST_TIM_MED[2:0]			32h	1	
P2	06h	1st	W/R	Dynamic Backlight Control 2	0	PWM_DUTY_PRECISION[2:0]		0	LEDPW_M_POL	LEDON_POL	LEDON	00h	1	
P2	07h	1st	W/R		PWM_DIV[7:0]								0Eh	1
P2	10h	1st	W/R	IIE Function Control	0	0	0	0	0	PRT_EN	SKIN_EN	0	06h	1
P2	11h	1st	W/R		0	AUTO_M_EAN	0	0	CN_EN	CN_INV	SHP_EN	0	00h	1
P2	12h	1st	W/R		0	0	0	0	0	CN_LV[1:0]		02h	1	
P2	13h	1st	W/R		0	0	1	0	SRE_MIDIV_LV[1:0]		0	0	20h	1
P2	15h	1st	W/R		RGB_MEAN[7:0]								80h	1
P2	16h	1st	W/R		SRE_HYS_TERESIS_EN	0	0	SRE_DIM_EN	SRE_SC_EN	SRE_CE_EN	0	0	1Ch	1
P2	17h	1st	W/R		0	SRE_OFFS[2:0]		0	SRE_DIM_STP[2:0]		01h			1
P2	18h	1st	W/R		SRE_DIM_FRAME[7:0]								08h	1
P2	19h	1st	W/R		SRE_SC_GAIN_ADJ[2:0]				SRE_HYSTERESIS_LIMIT[4:0]				C0h	1
P2	1Ah	1st	W/R		IIE Saturation Enhancement Control 1		0	0	SE_RATIO_L[5:0]				07h	1
P2	1Bh	1st	W/R	0		0	SE_RATIO_M[5:0]				09h	1		
P2	1Ch	1st	W/R	0		0	SE_RATIO_H[5:0]				0Ch	1		
P2	40h	1st	W/R	IIE Saturation Protection Control	0	0	0	LEVEL0_SR[4:0]				02h	1	
P2	41h	1st	W/R		0	0	0	LEVEL1_SR[4:0]				04h	1	
P2	42h	1st	W/R		0	0	0	LEVEL2_SR[4:0]				06h	1	
P2	43h	1st	W/R		0	0	0	LEVEL3_SR[4:0]				08h	1	
P2	44h	1st	W/R		0	0	0	LEVEL4_SR[4:0]				0Ah	1	
P2	45h	1st	W/R		0	0	0	LEVEL5_SR[4:0]				0Ch	1	
P2	46h	1st	W/R		0	0	0	LEVEL6_SR[4:0]				0Eh	1	
P2	47h	1st	W/R		0	0	0	LEVEL7_SR[4:0]				0Eh	1	
P2	48h	1st	W/R		0	0	0	LEVEL8_SR[4:0]				0Ch	1	
P2	49h	1st	W/R		0	0	0	LEVEL9_SR[4:0]				0Ah	1	
P2	4Ah	1st	W/R		0	0	0	LEVEL10_SR[4:0]				08h	1	
P2	4Bh	1st	W/R		0	0	0	LEVEL11_SR[4:0]				06h	1	
P2	4Ch	1st	W/R		0	0	0	LEVEL12_SR[4:0]				04h	1	
P2	4Dh	1st	W/R		0	0	0	LEVEL13_SR[4:0]				03h	1	
P2	4Eh	1st	W/R		0	0	0	LEVEL14_SR[4:0]				02h	1	
P2	4Fh	1st	W/R	0	0	0	LEVEL15_SR[4:0]				00h	1		
P2	5Ah	1st	W/R	IIE Sharpness Enhancement Control	0	0	0	SHP_RATIO[4:0]				18h	1	
P2	5Bh	1st	W/R		SHP_THR_H[7:0]								64h	1
P2	5Ch	1st	W/R		SHP_THR_L[7:0]								1Eh	1
P2	60h	1st	W/R	IIE Contrast Enhancement Control	0	0	CN_00[5:0]				0Eh	1		
P2	61h	1st	W/R		0	0	CN_01[5:0]				18h	1		
P2	62h	1st	W/R		0	0	CN_02[5:0]				24h	1		
P2	63h	1st	W/R		0	0	CN_03[5:0]				28h	1		
P2	64h	1st	W/R		0	0	CN_04[5:0]				24h	1		
P2	65h	1st	W/R		0	0	CN_05[5:0]				18h	1		
P2	66h	1st	W/R		0	0	CN_06[5:0]				0Eh	1		
P2	FFh	1st	W	EXTC Command Set Enable Register	1	0	0	1	1	0	0	0	98h	-
		2nd	W		1	0	0	0	0	0	0	1	81h	-
		3rd	W		PAGE[7:0]								02h	-

5.2.4. Page 3 Command Set

Command			W/R	Function	D7	D6	D5	D4	D3	D2	D1	D0	Default (hex)	MTP (times)
Page	Address	Parameter												
P3	FFh	1st	W	EXTC Command Set Enable Register	1	0	0	1	1	0	0	0	98h	-
		2nd	W		1	0	0	0	0	0	0	1	81h	-
		3rd	W	PAGE[7:0]										03h

5.2.5. Page 4 Command Set

Command			W/R	Function	D7	D6	D5	D4	D3	D2	D1	D0	Default (hex)	MTP (times)	
Page	Address	Parameter													
P4	00h	1st	W/R	DSI Lanes Control	MIPI_LANE_SEL	0	0	0	0	0	0	0	80h	1	
P4	0Bh	1st	W/R	SSC Function	SSC_DIG_EN	SSC_DIG_STEP[2:0]			0	0	0	0	00h	-	
P4	0Eh	1st	W/R		SSC_DIG_CNT[7:0]								00h	-	
P4	21h	1st	W/R	Charge-Pump Setting	DMY_PUMP	0	1	1	0	0	0	0	B0h	1	
P4	23h	1st	W/R	Idle Mode Frame Rate	RTNB[7:0]								2Dh	1	
P4	26h	1st	W/R	Internal SD Timing Control	DET_TOLERANCE_OP[3:0]				0	1	1	0	76h	1	
P4	27h	1st	W/R	Touch Synchronization Timing Adjust	TOUCH_OPT[1:0]		VSOD[1:0]		HSOM[1:0]		HFP_HBP_OPT	VS_PW_OPT	00h	1	
P4	28h	1st	W/R		HSOD[7:0]								05h	1	
P4	29h	1st	W/R		HSOHW[7:0]								19h	1	
P4	2Ah	1st	W/R		VS_OUT_EN	HS_OUT_EN	VS_OUT_POL	HS_OUT_POL	0	0	STB_EN	0	F0h	1	
P4	2Dh	1st	W/R	BIST Mode Function	FRM_PT[7:0]								FFh	1	
P4	2Fh	1st	W/R		0	0	FRM_CYC[1:0]		0	0	0	FRM_EN	00h	1	
P4	35h	1st	W/R	Source Timing Setting	0	0	0	1	HZ_OPT	1	1	1	17h	1	
P4	3Ah	1st	W/R	Power Saving Control	PS_EN	PCST[6:0]						A4h	1		
P4	69h	1st	W/R	Power Control 1	1	CP_VCL_CLP_OPTION_PRE[2:0]			0	1	1	1	D7h	-	
P4	6Eh	1st	W/R	Power Control 2	0	DI_PWR_REG	REG1_VRH_CP[5:0]					6Ah	1		
P4	6Fh	1st	W/R	Power Control 3	VGLREG_EN_GO	DI_CP_VGH_BH[2:0]			DI_CP_VGL_BL[2:0]			DI_CP_VCL_REG_SEL	34h	1	
P4	7Ah	1st	W/R	VREG1/2 Setting	0	0	0	DI_REG1_EN_CAP	0	0	0	0	00h	1	
P4	87h	1st	W/R	LVD Function 1	DI_LVD_CTL[3:0]				1	0	1	0	BAh	1	
P4	88h	1st	W/R	LVD Function 2	DIS_LVD_CHK	0	0	0	1	0	1	1	8Bh	1	
P4	8Bh	1st	W/R	VCOM Control 2	1	1	1	0	DI_VCM_SELO_E	0	1	1	E3h	1	
P4	8Ch	1st	W/R	Power Control 4	0	DI_VCOM_REG_VGLREG[6:0]						03h	1		
P4	8Dh	1st	W/R		0	DI_VCOM_CP_VGLCLP[6:0]						14h	1		
P4	B2h	1st	W/R	Reload Gamma Setting	RELOAD_GMA_EN	RELOAD_GMA_L	0	1	0	0	0	1	D1h	1	
P4	B5h	1st	W/R	Gamma Bias Level	0	0	0	0	DI_GMA_GAP[2:0]				02h	1	
P4	BBh	1st	W/R	TS_CTRL 1	EN_TEMPL_PROC	0	CP_VGH_TAP_C[5:0]					1Eh	1		
P4	BCh	1st	W/R		0	0	CP_VGH_TAP_L[5:0]					1Eh	1		
P4	BDh	1st	W/R		0	0	CP_VGH_TAP_M[5:0]					1Eh	1		
P4	BEh	1st	W/R		0	0	CP_VGH_TAP_H[5:0]					1Eh	1		
P4	BFh	1st	W/R		VCOM_C[7:0]								4Ch	1	
P4	C0h	1st	W/R		VCOM_L[7:0]								4Ch	1	
P4	C1h	1st	W/R		VCOM_M[7:0]								4Ch	1	
P4	C2h	1st	W/R		VCOM_H[7:0]								4Ch	1	
P4	C4h	1st	R	Read VCOM OTP Data	0	0	0	0	0	0	0	0	OTP_VCM1[8]	00h	-
P4	C5h	1st	R		OTP_VCM1[7:0]								7Bh	-	
P4	C6h	1st	R		0	0	0	0	0	0	0	0	OTP_VCM2[8]	00h	-
P4	C7h	1st	R		OTP_VCM2[7:0]								7Bh	-	

Command			W/R	Function	D7	D6	D5	D4	D3	D2	D1	D0	Default (hex)	MTP (times)	
Page	Address	Parameter													
P4	C8h	1st	W/R	TS_CTRL 2	TS_TH0[7:0]							00h	-		
P4	C9h	1st	W/R		TS_TH1[7:0]							00h	-		
P4	CAh	1st	W/R		TS_TH2[7:0]							00h	-		
P4	CBh	1st	W/R		TS_TH3[7:0]							00h	-		
P4	CCh	1st	W/R		TS_TH0[9:8]	TS_TH1[9:8]	TS_TH2[9:8]	TS_TH3[9:8]				00h	1		
P4	CDh	1st	W/R		TS_DEBT_OPT[3:0]			TS_HYST_OPT[3:0]						02h	1
P4	CEh	1st	W/R		EN_TS	VCOM_C [8]	VCOM_L [8]	VCOM_M [8]	VCOM_H [8]	1	0	0	04h	1	
P4	D7h	1st	W/R		OTP Control	0	0	0	OTP_PA TH	PROG_SEL[1:0]		0	0	1C	-
P4	FFh	1st	W	EXTC Command Set Enable Register	1	0	0	1	1	0	0	0	98h	-	
		2nd	W		1	0	0	0	0	0	0	1	81h	-	
		3rd	W		PAGE[7:0]									04h	-

5.2.6. Page 5 Command Set

Command			W/R	Function	D7	D6	D5	D4	D3	D2	D1	D0	Default (hex)	MTP (times)
Page	Address	Parameter												
P5	00h	1st	W	Fine Digital Gamma Control 1	RDIN0[7:0]							00h	-	
P5	01h	1st	W		RDIN1[7:0]							00h	-	
P5	02h	1st	W		RDIN2[7:0]							00h	-	
P5	03h	1st	W		RDIN3[7:0]							00h	-	
P5	04h	1st	W		RDIN4[7:0]							00h	-	
P5	05h	1st	W		RDIN5[7:0]							00h	-	
P5	:	1st	W		:							00h	-	
P5	7Ah	1st	W		RDIN122[7:0]							00h	-	
P5	7Bh	1st	W		RDIN123[7:0]							00h	-	
P5	7Ch	1st	W		RDIN124[7:0]							00h	-	
P5	7Dh	1st	W		RDIN125[7:0]							00h	-	
P5	7Eh	1st	W		RDIN126[7:0]							00h	-	
P5	7Fh	1st	W		RDIN127[7:0]							00h	-	
P5	80h	1st	W/R		Digital 3 Gamma Enable	0	0	0	0	0	0	0	EN_3G	00h
P5	FFh	1st	W	EXTC Command Set Enable Register	1	0	0	1	1	0	0	0	98h	-
		2nd	W		1	0	0	0	0	0	1	81h	-	
		3rd	W		PAGE[7:0]							05h	-	

5.2.7. Page 6 Command Set

Command			W/R	Function	D7	D6	D5	D4	D3	D2	D1	D0	Default (hex)	MTP (times)
Page	Address	Parameter												
P6	00h	1st	W	Fine Digital Gamma Control 2	RDIN128[7:0]							00h	-	
P6	01h	1st	W		RDIN129[7:0]							00h	-	
P6	02h	1st	W		RDIN130[7:0]							00h	-	
P6	03h	1st	W		RDIN131[7:0]							00h	-	
P6	04h	1st	W		RDIN132[7:0]							00h	-	
P6	05h	1st	W		RDIN133[7:0]							00h	-	
P6	:	1st	W		:							00h	-	
P6	7Ah	1st	W		RDIN250[7:0]							00h	-	
P6	7Bh	1st	W		RDIN251[7:0]							00h	-	
P6	7Ch	1st	W		RDIN252[7:0]							00h	-	
P6	7Dh	1st	W		RDIN253[7:0]							00h	-	
P6	7Eh	1st	W		RDIN254[7:0]							00h	-	
P6	7Fh	1st	W		RDIN255[7:0]							00h	-	
P6	FFh	1st	W		EXTC Command Set Enable Register	1	0	0	1	1	0	0	0	98h
		2nd	W	1		0	0	0	0	0	1	81h	-	
		3rd	W	PAGE[7:0]							06h	-		

5.2.8. Page 7 Command Set

Command			W/R	Function	D7	D6	D5	D4	D3	D2	D1	D0	Default (hex)	MTP (times)
Page	Address	Parameter												
P7	00h	1st	W	Fine Digital Gamma Control 3	GDIN0[7:0]							00h	-	
P7	01h	1st	W		GDIN1[7:0]							00h	-	
P7	02h	1st	W		GDIN2[7:0]							00h	-	
P7	03h	1st	W		GDIN3[7:0]							00h	-	
P7	04h	1st	W		GDIN4[7:0]							00h	-	
P7	05h	1st	W		GDIN5[7:0]							00h	-	
P7	:	1st	W		:							00h	-	
P7	7Ah	1st	W		GDIN122[7:0]							00h	-	
P7	7Bh	1st	W		GDIN123[7:0]							00h	-	
P7	7Ch	1st	W		GDIN124[7:0]							00h	-	
P7	7Dh	1st	W		GDIN125[7:0]							00h	-	
P7	7Eh	1st	W		GDIN126[7:0]							00h	-	
P7	7Fh	1st	W		GDIN127[7:0]							00h	-	
P7	FFh	1st	W		EXTC Command Set	1	0	0	1	1	0	0	0	98h
		2nd	W	Enable Register	1	0	0	0	0	0	0	1	81h	-
		3rd	W		PAGE[7:0]							07h	-	

5.2.9. Page 8 Command Set

Command			W/R	Function	D7	D6	D5	D4	D3	D2	D1	D0	Default (hex)	MTP (times)
Page	Address	Parameter												
P8	00h	1st	W	Fine Digital Gamma Control 4	GDIN128[7:0]							00h	-	
P8	01h	1st	W		GDIN129[7:0]							00h	-	
P8	02h	1st	W		GDIN130[7:0]							00h	-	
P8	03h	1st	W		GDIN131[7:0]							00h	-	
P8	04h	1st	W		GDIN132[7:0]							00h	-	
P8	05h	1st	W		GDIN133[7:0]							00h	-	
P8	:	1st	W		:							00h	-	
P8	7Ah	1st	W		GDIN250[7:0]							00h	-	
P8	7Bh	1st	W		GDIN251[7:0]							00h	-	
P8	7Ch	1st	W		GDIN252[7:0]							00h	-	
P8	7Dh	1st	W		GDIN253[7:0]							00h	-	
P8	7Eh	1st	W		GDIN254[7:0]							00h	-	
P8	7Fh	1st	W		GDIN255[7:0]							00h	-	
P8	FFh	1st	W		EXTC Command Set	1	0	0	1	1	0	0	0	98h
		2nd	W	Enable Register	1	0	0	0	0	0	0	1	81h	-
		3rd	W		PAGE[7:0]							08h	-	

5.2.10. Page 9 Command Set

Command			W/R	Function	D7	D6	D5	D4	D3	D2	D1	D0	Default (hex)	MTP (times)
Page	Address	Parameter												
P9	00h	1st	W	Fine Digital Gamma Control 5	BDIN0[7:0]							00h	-	
P9	01h	1st	W		BDIN1[7:0]							00h	-	
P9	02h	1st	W		BDIN2[7:0]							00h	-	
P9	03h	1st	W		BDIN3[7:0]							00h	-	
P9	04h	1st	W		BDIN4[7:0]							00h	-	
P9	05h	1st	W		BDIN5[7:0]							00h	-	
P9	:	1st	W		:							00h	-	
P9	7Ah	1st	W		BDIN122[7:0]							00h	-	
P9	7Bh	1st	W		BDIN123[7:0]							00h	-	
P9	7Ch	1st	W		BDIN124[7:0]							00h	-	
P9	7Dh	1st	W		BDIN125[7:0]							00h	-	
P9	7Eh	1st	W		BDIN126[7:0]							00h	-	
P9	7Fh	1st	W		BDIN127[7:0]							00h	-	
P9	FFh	1st	W		EXTC Command Set	1	0	0	1	1	0	0	0	98h
		2nd	W	Enable Register	1	0	0	0	0	0	0	1	81h	-
		3rd	W		PAGE[7:0]							09h	-	

5.2.11. Page 10 Command Set

Command			W/R	Function	D7	D6	D5	D4	D3	D2	D1	D0	Default (hex)	MTP (times)
Page	Address	Parameter												
P10	00h	1st	W	Fine Digital Gamma Control 6	BDIN128[7:0]							00h	-	
P10	01h	1st	W		BDIN129[7:0]							00h	-	
P10	02h	1st	W		BDIN130[7:0]							00h	-	
P10	03h	1st	W		BDIN131[7:0]							00h	-	
P10	04h	1st	W		BDIN132[7:0]							00h	-	
P10	05h	1st	W		BDIN133[7:0]							00h	-	
P10	:	1st	W		:							00h	-	
P10	7Ah	1st	W		BDIN250[7:0]							00h	-	
P10	7Bh	1st	W		BDIN251[7:0]							00h	-	
P10	7Ch	1st	W		BDIN252[7:0]							00h	-	
P10	7Dh	1st	W		BDIN253[7:0]							00h	-	
P10	7Eh	1st	W		BDIN254[7:0]							00h	-	
P10	7Fh	1st	W		BDIN255[7:0]							00h	-	
P10	FFh	1st	W		EXTC Command Set	1	0	0	1	1	0	0	0	98h
		2nd	W	Enable Register	1	0	0	0	0	0	0	1	81h	-
		3rd	W		PAGE[7:0]							0Ah	-	

5.3. Page 0 Command Description

5.3.1. NOP (00h)

Command Page			Page 0																
Address	Parameter	W/R	D7	D6	D5	D4	D3	D2	D1	D0	Default								
00h	-	W	No Argument								-								
Description	<p>00h: NOP (No Operation).</p> <p>This command is an empty command. It does not have any effect on the ILI9881C-0D.</p> <p>However, it can be used to terminate Memory Write or Memory Write Continue as described in RAMWR (Memory Write) and RAMWRC (Memory Write Continue) Commands.</p>																		
Restriction	None																		
Register Availability	<table border="1"> <thead> <tr> <th>Status</th> <th>Availability</th> </tr> </thead> <tbody> <tr> <td>Normal Mode On, Idle Mode Off, Sleep Out</td> <td>Yes</td> </tr> <tr> <td>Normal Mode On, Idle Mode On, Sleep Out</td> <td>Yes</td> </tr> <tr> <td>Sleep In</td> <td>Yes</td> </tr> </tbody> </table>											Status	Availability	Normal Mode On, Idle Mode Off, Sleep Out	Yes	Normal Mode On, Idle Mode On, Sleep Out	Yes	Sleep In	Yes
Status	Availability																		
Normal Mode On, Idle Mode Off, Sleep Out	Yes																		
Normal Mode On, Idle Mode On, Sleep Out	Yes																		
Sleep In	Yes																		
Default	<table border="1"> <thead> <tr> <th>Status</th> <th>Default Value</th> </tr> </thead> <tbody> <tr> <td>Power On Sequence</td> <td>N/A</td> </tr> <tr> <td>S/W Reset</td> <td>N/A</td> </tr> <tr> <td>H/W Reset</td> <td>N/A</td> </tr> </tbody> </table>											Status	Default Value	Power On Sequence	N/A	S/W Reset	N/A	H/W Reset	N/A
Status	Default Value																		
Power On Sequence	N/A																		
S/W Reset	N/A																		
H/W Reset	N/A																		
Flow Chart																			

5.3.2. Software Reset (01h)

Command Page			Page 0																
Address	Parameter	W/R	D7	D6	D5	D4	D3	D2	D1	D0	Default								
01h	-	W	No Argument									-							
Description	<p>01h: SWRESET (Software Reset).</p> <p>When the Software Reset command is written, it causes software reset. It resets the commands and parameters to their S/W Reset default values. (See default tables in each command description.)</p> <p>The display is blank immediately.</p> <p><i>Note: The Frame Memory content is kept or not by this command</i></p>																		
Restriction	<p>It is necessary to wait 5msec before sending a new command after software reset. The display module loads all factory default values of the display supplier to the registers during this 5msec. If Software Reset is applied during the Sleep Out mode, it will be necessary to wait 120msec for Sleep In sequence before sending the Sleep Out command.</p> <p>The Software Reset Command cannot be sent during the Sleep Out sequence.</p>																		
Register Availability	<table border="1"> <thead> <tr> <th>Status</th> <th>Availability</th> </tr> </thead> <tbody> <tr> <td>Normal Mode On, Idle Mode Off, Sleep Out</td> <td>Yes</td> </tr> <tr> <td>Normal Mode On, Idle Mode On, Sleep Out</td> <td>Yes</td> </tr> <tr> <td>Sleep In</td> <td>Yes</td> </tr> </tbody> </table>											Status	Availability	Normal Mode On, Idle Mode Off, Sleep Out	Yes	Normal Mode On, Idle Mode On, Sleep Out	Yes	Sleep In	Yes
Status	Availability																		
Normal Mode On, Idle Mode Off, Sleep Out	Yes																		
Normal Mode On, Idle Mode On, Sleep Out	Yes																		
Sleep In	Yes																		
Default	<table border="1"> <thead> <tr> <th>Status</th> <th>Default Value</th> </tr> </thead> <tbody> <tr> <td>Power On Sequence</td> <td>N/A</td> </tr> <tr> <td>S/W Reset</td> <td>N/A</td> </tr> <tr> <td>H/W Reset</td> <td>N/A</td> </tr> </tbody> </table>											Status	Default Value	Power On Sequence	N/A	S/W Reset	N/A	H/W Reset	N/A
Status	Default Value																		
Power On Sequence	N/A																		
S/W Reset	N/A																		
H/W Reset	N/A																		
Flow Chart	<pre> graph TD A[SWRESET] --> B{{Display whole blank screen}} B --> C{{Set Commands to S/W Default Value}} C --> D([Sleep In Mode]) </pre> <p>Legend</p> <ul style="list-style-type: none"> Command: Rectangle Parameter: Parallelogram Display: Hexagon Action: Pentagon Mode: Oval Sequential transfer: Cloud 																		

5.3.3. Read Number of the Errors on DSI (05h)

Command Page			Page 0																
Address	Parameter	W/R	D7	D6	D5	D4	D3	D2	D1	D0	Default								
05h	1st	R	P[7:0]									00h							
Description	<p>05h: RDNUMED (Read Number of the Errors on DSI).</p> <p>The parameter indicates the amount of errors on the DSI. The more detailed description of the bits is below.</p> <p>P[6..0] bits indicate the amount of the error.</p> <p>P[7] is set to 1 if there is overflow with P[6..0] bits.</p> <p>P[7..0] bits are set to 0 (and RDDSM (0Eh)'s D0 is set 0 at the same time) after the parameter information is sent (= the read function is completed).</p> <p>See also sections: "4.1.3.2.2 Acknowledge with Error Report (AwER)" and "5.3.9 Read Display Signal Mode (0Eh)".</p>																		
Restriction	None																		
Register Availability	<table border="1"> <thead> <tr> <th>Status</th> <th>Availability</th> </tr> </thead> <tbody> <tr> <td>Normal Mode On, Idle Mode Off, Sleep Out</td> <td>Yes</td> </tr> <tr> <td>Normal Mode On, Idle Mode On, Sleep Out</td> <td>Yes</td> </tr> <tr> <td>Sleep In</td> <td>Yes</td> </tr> </tbody> </table>											Status	Availability	Normal Mode On, Idle Mode Off, Sleep Out	Yes	Normal Mode On, Idle Mode On, Sleep Out	Yes	Sleep In	Yes
Status	Availability																		
Normal Mode On, Idle Mode Off, Sleep Out	Yes																		
Normal Mode On, Idle Mode On, Sleep Out	Yes																		
Sleep In	Yes																		
Default	<table border="1"> <thead> <tr> <th>Status</th> <th>Default Value</th> </tr> </thead> <tbody> <tr> <td>Power On Sequence</td> <td>00h</td> </tr> <tr> <td>S/W Reset</td> <td>00h</td> </tr> <tr> <td>H/W Reset</td> <td>00h</td> </tr> </tbody> </table>											Status	Default Value	Power On Sequence	00h	S/W Reset	00h	H/W Reset	00h
Status	Default Value																		
Power On Sequence	00h																		
S/W Reset	00h																		
H/W Reset	00h																		
Flow Chart																			

5.3.4. Read Display Status (09h)

Command Page			Page 0																																																																																																								
Address	Parameter	W/R	D7	D6	D5	D4	D3	D2	D1	D0	Default																																																																																																
09h	1st	R	D31	0	0	0	0	D26	0	D24	00h																																																																																																
	2nd	R	D23	0	0	0	D19	0	D17	D16	01h																																																																																																
	3rd	R	0	0	0	D12	D11	D10	D9	D8	00h																																																																																																
	4th	R	D7	D6	D5	0	0	0	0	D0	00h																																																																																																
Description	This command indicates the current status of the display, as described in the table below:																																																																																																										
	<table border="1"> <thead> <tr> <th>Bit</th> <th>Description</th> <th>Value</th> <th>Status</th> </tr> </thead> <tbody> <tr> <td rowspan="2">D31</td> <td rowspan="2">Booster voltage status</td> <td>0</td> <td>Booster Off</td> </tr> <tr> <td>1</td> <td>Booster On</td> </tr> <tr> <td rowspan="2">D26</td> <td rowspan="2">RGB/BGR order</td> <td>0</td> <td>RGB (When MADCTL D3 = 0)</td> </tr> <tr> <td>1</td> <td>BGR (When MADCTL D3= 1)</td> </tr> <tr> <td rowspan="2">D24</td> <td rowspan="2">Source scan sequence</td> <td>0</td> <td>Source output Left to Right (When MADCTL D1 = 0)</td> </tr> <tr> <td>1</td> <td>Source output Right to Left (When MADCTL D1 = 1)</td> </tr> <tr> <td rowspan="2">D23</td> <td rowspan="2">Gate scan sequence</td> <td>0</td> <td>Gate output Top to Bottom (When MADCTL D0 = 0)</td> </tr> <tr> <td>1</td> <td>Gate output Bottom to Top (When MADCTL D0 = 1)</td> </tr> <tr> <td rowspan="2">D19</td> <td rowspan="2">Idle Mode On/Off</td> <td>0</td> <td>Idle Mode Off</td> </tr> <tr> <td>1</td> <td>Idle Mode On</td> </tr> <tr> <td rowspan="2">D17</td> <td rowspan="2">Sleep In/Out</td> <td>0</td> <td>Sleep In Mode</td> </tr> <tr> <td>1</td> <td>Sleep Out Mode</td> </tr> <tr> <td rowspan="2">D16</td> <td rowspan="2">Display Normal Mode On/Off</td> <td>0</td> <td>Display Normal Mode Off (All Pixels Off or All Pixels On mode)</td> </tr> <tr> <td>1</td> <td>Display Normal Mode On</td> </tr> <tr> <td rowspan="2">D13</td> <td rowspan="2">Inversion status</td> <td>0</td> <td>Inversion Off</td> </tr> <tr> <td>1</td> <td>Inversion On</td> </tr> <tr> <td rowspan="2">D12</td> <td rowspan="2">All Pixel On</td> <td>0</td> <td>Normal mode</td> </tr> <tr> <td>1</td> <td>All Pixels On</td> </tr> <tr> <td rowspan="2">D11</td> <td rowspan="2">All Pixel Off</td> <td>0</td> <td>Normal mode</td> </tr> <tr> <td>1</td> <td>All Pixels Off</td> </tr> <tr> <td rowspan="2">D10</td> <td rowspan="2">Display ON/OFF</td> <td>0</td> <td>Display is OFF</td> </tr> <tr> <td>1</td> <td>Display is ON</td> </tr> <tr> <td rowspan="2">D9</td> <td rowspan="2">TE ON/OFF</td> <td>0</td> <td>TE OFF</td> </tr> <tr> <td>1</td> <td>TE ON</td> </tr> <tr> <td>D8</td> <td rowspan="3">Gamma Curve Selection [2:0]</td> <td>000</td> <td>Gamma Curve 1</td> </tr> <tr> <td>D7</td> <td rowspan="2">others</td> <td rowspan="2">Not defined</td> </tr> <tr> <td>D6</td> </tr> <tr> <td rowspan="2">D5</td> <td rowspan="2">TE Mode</td> <td>0</td> <td>TE Mode 1</td> </tr> <tr> <td>1</td> <td>TE Mode 2</td> </tr> <tr> <td rowspan="2">D0</td> <td rowspan="2">Parity Error on DSI</td> <td>0</td> <td>No Parity Error</td> </tr> <tr> <td>1</td> <td>Parity Error</td> </tr> </tbody> </table>											Bit	Description	Value	Status	D31	Booster voltage status	0	Booster Off	1	Booster On	D26	RGB/BGR order	0	RGB (When MADCTL D3 = 0)	1	BGR (When MADCTL D3= 1)	D24	Source scan sequence	0	Source output Left to Right (When MADCTL D1 = 0)	1	Source output Right to Left (When MADCTL D1 = 1)	D23	Gate scan sequence	0	Gate output Top to Bottom (When MADCTL D0 = 0)	1	Gate output Bottom to Top (When MADCTL D0 = 1)	D19	Idle Mode On/Off	0	Idle Mode Off	1	Idle Mode On	D17	Sleep In/Out	0	Sleep In Mode	1	Sleep Out Mode	D16	Display Normal Mode On/Off	0	Display Normal Mode Off (All Pixels Off or All Pixels On mode)	1	Display Normal Mode On	D13	Inversion status	0	Inversion Off	1	Inversion On	D12	All Pixel On	0	Normal mode	1	All Pixels On	D11	All Pixel Off	0	Normal mode	1	All Pixels Off	D10	Display ON/OFF	0	Display is OFF	1	Display is ON	D9	TE ON/OFF	0	TE OFF	1	TE ON	D8	Gamma Curve Selection [2:0]	000	Gamma Curve 1	D7	others	Not defined	D6	D5	TE Mode	0	TE Mode 1	1	TE Mode 2	D0	Parity Error on DSI	0	No Parity Error	1	Parity Error
	Bit	Description	Value	Status																																																																																																							
	D31	Booster voltage status	0	Booster Off																																																																																																							
			1	Booster On																																																																																																							
	D26	RGB/BGR order	0	RGB (When MADCTL D3 = 0)																																																																																																							
			1	BGR (When MADCTL D3= 1)																																																																																																							
	D24	Source scan sequence	0	Source output Left to Right (When MADCTL D1 = 0)																																																																																																							
			1	Source output Right to Left (When MADCTL D1 = 1)																																																																																																							
	D23	Gate scan sequence	0	Gate output Top to Bottom (When MADCTL D0 = 0)																																																																																																							
			1	Gate output Bottom to Top (When MADCTL D0 = 1)																																																																																																							
	D19	Idle Mode On/Off	0	Idle Mode Off																																																																																																							
			1	Idle Mode On																																																																																																							
	D17	Sleep In/Out	0	Sleep In Mode																																																																																																							
			1	Sleep Out Mode																																																																																																							
	D16	Display Normal Mode On/Off	0	Display Normal Mode Off (All Pixels Off or All Pixels On mode)																																																																																																							
			1	Display Normal Mode On																																																																																																							
	D13	Inversion status	0	Inversion Off																																																																																																							
			1	Inversion On																																																																																																							
	D12	All Pixel On	0	Normal mode																																																																																																							
			1	All Pixels On																																																																																																							
	D11	All Pixel Off	0	Normal mode																																																																																																							
			1	All Pixels Off																																																																																																							
	D10	Display ON/OFF	0	Display is OFF																																																																																																							
			1	Display is ON																																																																																																							
	D9	TE ON/OFF	0	TE OFF																																																																																																							
			1	TE ON																																																																																																							
D8	Gamma Curve Selection [2:0]	000	Gamma Curve 1																																																																																																								
D7		others	Not defined																																																																																																								
D6																																																																																																											
D5	TE Mode	0	TE Mode 1																																																																																																								
		1	TE Mode 2																																																																																																								
D0	Parity Error on DSI	0	No Parity Error																																																																																																								
		1	Parity Error																																																																																																								
Restriction	None																																																																																																										

<p>Register Availability</p>	<table border="1"> <thead> <tr> <th data-bbox="608 230 1050 264">Status</th> <th data-bbox="1050 230 1289 264">Availability</th> </tr> </thead> <tbody> <tr> <td data-bbox="608 264 1050 297">Normal Mode On, Idle Mode Off, Sleep Out</td> <td data-bbox="1050 264 1289 297">Yes</td> </tr> <tr> <td data-bbox="608 297 1050 331">Normal Mode On, Idle Mode On, Sleep Out</td> <td data-bbox="1050 297 1289 331">Yes</td> </tr> <tr> <td data-bbox="608 331 1050 365">Sleep In</td> <td data-bbox="1050 331 1289 365">Yes</td> </tr> </tbody> </table>	Status	Availability	Normal Mode On, Idle Mode Off, Sleep Out	Yes	Normal Mode On, Idle Mode On, Sleep Out	Yes	Sleep In	Yes
Status	Availability								
Normal Mode On, Idle Mode Off, Sleep Out	Yes								
Normal Mode On, Idle Mode On, Sleep Out	Yes								
Sleep In	Yes								
<p>Default</p>	<table border="1"> <thead> <tr> <th data-bbox="496 421 746 454">Status</th> <th data-bbox="746 421 1401 454">Default Value</th> </tr> </thead> <tbody> <tr> <td data-bbox="496 454 746 488">Power On Sequence</td> <td data-bbox="746 454 1401 488">00h_01h_00h_00h</td> </tr> <tr> <td data-bbox="496 488 746 521">S/W Reset</td> <td data-bbox="746 488 1401 521">00h_01h_00h_00h</td> </tr> <tr> <td data-bbox="496 521 746 555">H/W Reset</td> <td data-bbox="746 521 1401 555">00h_01h_00h_00h</td> </tr> </tbody> </table>	Status	Default Value	Power On Sequence	00h_01h_00h_00h	S/W Reset	00h_01h_00h_00h	H/W Reset	00h_01h_00h_00h
Status	Default Value								
Power On Sequence	00h_01h_00h_00h								
S/W Reset	00h_01h_00h_00h								
H/W Reset	00h_01h_00h_00h								

5.3.5. Read Display Power Mode (0Ah)

Command Page		Page 0																																										
Address	Parameter	W/R	D7	D6	D5	D4	D3	D2	D1	D0	Default																																	
0Ah	1st	R	D7	D6	0	D4	D3	D2	0	0	08h																																	
Description	0A: RDDPM (Read Display Power Mode). This command indicates the current status of the display, as described in the table below.																																											
	<table border="1"> <thead> <tr> <th>Bit</th> <th>Description</th> <th>Value</th> <th>Status</th> </tr> </thead> <tbody> <tr> <td rowspan="2">D7</td> <td rowspan="2">Booster Voltage Status</td> <td>0</td> <td>Booster Off or has a fault.</td> </tr> <tr> <td>1</td> <td>Booster On and working OK</td> </tr> <tr> <td rowspan="2">D6</td> <td rowspan="2">Idle Mode On/Off</td> <td>0</td> <td>Idle Mode Off</td> </tr> <tr> <td>1</td> <td>Idle Mode On</td> </tr> <tr> <td rowspan="2">D4</td> <td rowspan="2">Sleep In/Out</td> <td>0</td> <td>Sleep In Mode</td> </tr> <tr> <td>1</td> <td>Sleep Out Mode</td> </tr> <tr> <td rowspan="2">D3</td> <td rowspan="2">Display Normal Mode On/Off</td> <td>0</td> <td>Display Normal Mode Off</td> </tr> <tr> <td>1</td> <td>Display Normal Mode On</td> </tr> <tr> <td rowspan="2">D2</td> <td rowspan="2">Display On/Off</td> <td>0</td> <td>Display is Off</td> </tr> <tr> <td>1</td> <td>Display is On</td> </tr> </tbody> </table>											Bit	Description	Value	Status	D7	Booster Voltage Status	0	Booster Off or has a fault.	1	Booster On and working OK	D6	Idle Mode On/Off	0	Idle Mode Off	1	Idle Mode On	D4	Sleep In/Out	0	Sleep In Mode	1	Sleep Out Mode	D3	Display Normal Mode On/Off	0	Display Normal Mode Off	1	Display Normal Mode On	D2	Display On/Off	0	Display is Off	1
Bit	Description	Value	Status																																									
D7	Booster Voltage Status	0	Booster Off or has a fault.																																									
		1	Booster On and working OK																																									
D6	Idle Mode On/Off	0	Idle Mode Off																																									
		1	Idle Mode On																																									
D4	Sleep In/Out	0	Sleep In Mode																																									
		1	Sleep Out Mode																																									
D3	Display Normal Mode On/Off	0	Display Normal Mode Off																																									
		1	Display Normal Mode On																																									
D2	Display On/Off	0	Display is Off																																									
		1	Display is On																																									
Restriction	None																																											
Register Availability	<table border="1"> <thead> <tr> <th>Status</th> <th>Availability</th> </tr> </thead> <tbody> <tr> <td>Normal Mode On, Idle Mode Off, Sleep Out</td> <td>Yes</td> </tr> <tr> <td>Normal Mode On, Idle Mode On, Sleep Out</td> <td>Yes</td> </tr> <tr> <td>Sleep In</td> <td>Yes</td> </tr> </tbody> </table>											Status	Availability	Normal Mode On, Idle Mode Off, Sleep Out	Yes	Normal Mode On, Idle Mode On, Sleep Out	Yes	Sleep In	Yes																									
Status	Availability																																											
Normal Mode On, Idle Mode Off, Sleep Out	Yes																																											
Normal Mode On, Idle Mode On, Sleep Out	Yes																																											
Sleep In	Yes																																											
Default	<table border="1"> <thead> <tr> <th>Status</th> <th>Default Value</th> </tr> </thead> <tbody> <tr> <td>Power On Sequence</td> <td>08h</td> </tr> <tr> <td>S/W Reset</td> <td>08h</td> </tr> <tr> <td>H/W Reset</td> <td>08h</td> </tr> </tbody> </table>											Status	Default Value	Power On Sequence	08h	S/W Reset	08h	H/W Reset	08h																									
Status	Default Value																																											
Power On Sequence	08h																																											
S/W Reset	08h																																											
H/W Reset	08h																																											
Flow Chart	<pre> graph TD Host[Host] -- "Read RDDPM (Command)" --> Display((Display)) Display -- "Send Parameter (Parameter)" --> Host </pre>																																											

5.3.6. Read Display MADCTL (0Bh)

Command Page		Page 0																														
Address	Parameter	W/R	D7	D6	D5	D4	D3	D2	D1	D0	Default																					
0Bh	1st	R	0	0	0	0	D3	0	D1	D0	00h																					
Description	0B: RDDMADCTL (Read Display MADCTL). This command indicates the current status of the display, as described in the table below.																															
	<table border="1"> <thead> <tr> <th>Bit</th> <th>Description</th> <th>Value</th> <th>Status</th> </tr> </thead> <tbody> <tr> <td rowspan="2">D3</td> <td rowspan="2">RGB/BGR Order (RGB)</td> <td>0</td> <td>RGB (When MADCTL D3='0')</td> </tr> <tr> <td>1</td> <td>BGR (When MADCTL D3='1')</td> </tr> <tr> <td rowspan="2">D1</td> <td rowspan="2">Source scan sequence (SS)</td> <td>0</td> <td>Source output Left to Right (When MADCTL D1 = '0')</td> </tr> <tr> <td>1</td> <td>Source output Right to Left (When MADCTL D1 = '1')</td> </tr> <tr> <td rowspan="2">D0</td> <td rowspan="2">Gate scan sequence (GS)</td> <td>0</td> <td>Gate output Top to Bottom (When MADCTL D0 = '0')</td> </tr> <tr> <td>1</td> <td>Gate output Bottom to Top (When MADCTL D0 = '1')</td> </tr> </tbody> </table> <p><i>Note: For Bits D3, D1 and D0 also refer to 5.3.22Memory Access Control (36h).</i></p>											Bit	Description	Value	Status	D3	RGB/BGR Order (RGB)	0	RGB (When MADCTL D3='0')	1	BGR (When MADCTL D3='1')	D1	Source scan sequence (SS)	0	Source output Left to Right (When MADCTL D1 = '0')	1	Source output Right to Left (When MADCTL D1 = '1')	D0	Gate scan sequence (GS)	0	Gate output Top to Bottom (When MADCTL D0 = '0')	1
Bit	Description	Value	Status																													
D3	RGB/BGR Order (RGB)	0	RGB (When MADCTL D3='0')																													
		1	BGR (When MADCTL D3='1')																													
D1	Source scan sequence (SS)	0	Source output Left to Right (When MADCTL D1 = '0')																													
		1	Source output Right to Left (When MADCTL D1 = '1')																													
D0	Gate scan sequence (GS)	0	Gate output Top to Bottom (When MADCTL D0 = '0')																													
		1	Gate output Bottom to Top (When MADCTL D0 = '1')																													
Restriction	None																															
Register Availability	<table border="1"> <thead> <tr> <th>Status</th> <th>Availability</th> </tr> </thead> <tbody> <tr> <td>Normal Mode On, Idle Mode Off, Sleep Out</td> <td>Yes</td> </tr> <tr> <td>Normal Mode On, Idle Mode On, Sleep Out</td> <td>Yes</td> </tr> <tr> <td>Sleep In</td> <td>Yes</td> </tr> </tbody> </table>											Status	Availability	Normal Mode On, Idle Mode Off, Sleep Out	Yes	Normal Mode On, Idle Mode On, Sleep Out	Yes	Sleep In	Yes													
Status	Availability																															
Normal Mode On, Idle Mode Off, Sleep Out	Yes																															
Normal Mode On, Idle Mode On, Sleep Out	Yes																															
Sleep In	Yes																															
Default	<table border="1"> <thead> <tr> <th>Status</th> <th>Default Value</th> </tr> </thead> <tbody> <tr> <td>Power On Sequence</td> <td>00h</td> </tr> <tr> <td>S/W Reset</td> <td>00h</td> </tr> <tr> <td>H/W Reset</td> <td>00h</td> </tr> </tbody> </table>											Status	Default Value	Power On Sequence	00h	S/W Reset	00h	H/W Reset	00h													
Status	Default Value																															
Power On Sequence	00h																															
S/W Reset	00h																															
H/W Reset	00h																															
Flow Chart																																

5.3.7. Read Display Pixel Format (0Ch)

Command Page		Page 0																		
Address	Parameter	W/R	D7	D6	D5	D4	D3	D2	D1	D0	Default									
0Ch	1st	R	0	0	0	0	0	D[2:0]			07h									
Description	0Ch: RDDCOLMOD (Read Display COLMOD). This command indicates the current status of the display as described in the table below:																			
	<table border="1" style="margin-left: auto; margin-right: auto;"> <thead> <tr> <th>DBI[2:0]</th> <th>Interface Pixel Format</th> </tr> </thead> <tbody> <tr> <td>101</td> <td>16 bit/pixel</td> </tr> <tr> <td>110</td> <td>18 bit/pixel</td> </tr> <tr> <td>111</td> <td>24 bit/pixel</td> </tr> <tr> <td>Others</td> <td>Not defined</td> </tr> </tbody> </table> <p><i>Note: For D[2:0] also refer to 5.3.25 Interface Pixel Format (3Ah).</i></p>											DBI[2:0]	Interface Pixel Format	101	16 bit/pixel	110	18 bit/pixel	111	24 bit/pixel	Others
DBI[2:0]	Interface Pixel Format																			
101	16 bit/pixel																			
110	18 bit/pixel																			
111	24 bit/pixel																			
Others	Not defined																			
Restriction	None																			
Register Availability	<table border="1" style="margin-left: auto; margin-right: auto;"> <thead> <tr> <th>Status</th> <th>Availability</th> </tr> </thead> <tbody> <tr> <td>Normal Mode On, Idle Mode Off, Sleep Out</td> <td>Yes</td> </tr> <tr> <td>Normal Mode On, Idle Mode On, Sleep Out</td> <td>Yes</td> </tr> <tr> <td>Sleep In</td> <td>Yes</td> </tr> </tbody> </table>											Status	Availability	Normal Mode On, Idle Mode Off, Sleep Out	Yes	Normal Mode On, Idle Mode On, Sleep Out	Yes	Sleep In	Yes	
Status	Availability																			
Normal Mode On, Idle Mode Off, Sleep Out	Yes																			
Normal Mode On, Idle Mode On, Sleep Out	Yes																			
Sleep In	Yes																			
Default	<table border="1" style="margin-left: auto; margin-right: auto;"> <thead> <tr> <th>Status</th> <th>Default Value</th> </tr> </thead> <tbody> <tr> <td>Power On Sequence</td> <td>07h</td> </tr> <tr> <td>S/W Reset</td> <td>07h</td> </tr> <tr> <td>H/W Reset</td> <td>07h</td> </tr> </tbody> </table>											Status	Default Value	Power On Sequence	07h	S/W Reset	07h	H/W Reset	07h	
Status	Default Value																			
Power On Sequence	07h																			
S/W Reset	07h																			
H/W Reset	07h																			
Flow Chart	<div style="display: flex; align-items: center; justify-content: center;"> <div style="text-align: center; margin-right: 20px;"> <div style="border: 1px solid black; padding: 2px 10px; display: inline-block;">Read RDDCOLMOD</div> ↓ <div style="border: 1px solid black; padding: 2px 10px; display: inline-block;">Send Parameter</div> </div> <div style="text-align: center; margin-left: 20px;"> Host ----- Display </div> </div> <div style="margin-left: 20px;"> <div style="border: 1px dashed black; padding: 5px;"> <p style="text-align: center;">Legend</p> <div style="display: flex; flex-direction: column; gap: 5px;"> <div style="border: 1px solid black; padding: 2px; display: inline-block;">Command</div> <div style="border: 1px solid black; padding: 2px; transform: rotate(-15deg); display: inline-block;">Parameter</div> <div style="border: 1px solid black; padding: 2px; border-radius: 15px; display: inline-block;">Display</div> <div style="border: 1px solid black; padding: 2px; border-radius: 15px; display: inline-block;">Action</div> <div style="border: 1px solid black; padding: 2px; border-radius: 15px; display: inline-block;">Mode</div> <div style="border: 1px solid black; padding: 2px; border-radius: 15px; display: inline-block;">Sequential transfer</div> </div> </div> </div>																			

5.3.8. Read Display Image Mode (0Dh)

Command Page		Page 0																														
Address	Parameter	W/R	D7	D6	D5	D4	D3	D2	D1	D0	Default																					
0Dh	1st	R	0	0	0	D4	D3	D[2:0]			00h																					
Description	0D: RDDIM (Read Display Image Mode). This command indicates the Image Mode status of the display, as described in the Tables below:																															
	<table border="1"> <thead> <tr> <th>Bit</th> <th>Description</th> <th>Value</th> <th>Status</th> </tr> </thead> <tbody> <tr> <td rowspan="2">D4</td> <td rowspan="2">All Pixels On</td> <td>0</td> <td>Normal Display</td> </tr> <tr> <td>1</td> <td>White Display</td> </tr> <tr> <td rowspan="2">D3</td> <td rowspan="2">All Pixels Off</td> <td>0</td> <td>Normal Display</td> </tr> <tr> <td>1</td> <td>Black Display</td> </tr> </tbody> </table> <table border="1"> <thead> <tr> <th>D[2:0]</th> <th>Gamma Curve Selection</th> </tr> </thead> <tbody> <tr> <td>000</td> <td>Gamma curve 1</td> </tr> <tr> <td>Others</td> <td>Not defined</td> </tr> </tbody> </table> <p><i>Note: For D[2:0] also refer to "5.3.16 Gamma Set (26h)"</i></p>											Bit	Description	Value	Status	D4	All Pixels On	0	Normal Display	1	White Display	D3	All Pixels Off	0	Normal Display	1	Black Display	D[2:0]	Gamma Curve Selection	000	Gamma curve 1	Others
Bit	Description	Value	Status																													
D4	All Pixels On	0	Normal Display																													
		1	White Display																													
D3	All Pixels Off	0	Normal Display																													
		1	Black Display																													
D[2:0]	Gamma Curve Selection																															
000	Gamma curve 1																															
Others	Not defined																															
Restriction	None																															
Register Availability	<table border="1"> <thead> <tr> <th>Status</th> <th>Availability</th> </tr> </thead> <tbody> <tr> <td>Normal Mode On, Idle Mode Off, Sleep Out</td> <td>Yes</td> </tr> <tr> <td>Normal Mode On, Idle Mode On, Sleep Out</td> <td>Yes</td> </tr> <tr> <td>Sleep In</td> <td>Yes</td> </tr> </tbody> </table>											Status	Availability	Normal Mode On, Idle Mode Off, Sleep Out	Yes	Normal Mode On, Idle Mode On, Sleep Out	Yes	Sleep In	Yes													
Status	Availability																															
Normal Mode On, Idle Mode Off, Sleep Out	Yes																															
Normal Mode On, Idle Mode On, Sleep Out	Yes																															
Sleep In	Yes																															
Default	<table border="1"> <thead> <tr> <th>Status</th> <th>Default Value</th> </tr> </thead> <tbody> <tr> <td>Power On Sequence</td> <td>00h</td> </tr> <tr> <td>S/W Reset</td> <td>00h</td> </tr> <tr> <td>H/W Reset</td> <td>00h</td> </tr> </tbody> </table>											Status	Default Value	Power On Sequence	00h	S/W Reset	00h	H/W Reset	00h													
Status	Default Value																															
Power On Sequence	00h																															
S/W Reset	00h																															
H/W Reset	00h																															
Flow Chart	<pre> sequenceDiagram participant Host participant Display Host->>Display: Read RDDIM Display-->Host: Send Parameter </pre>																															

5.3.9. Read Display Signal Mode (0Eh)

Command Page		Page 0																																			
Address	Parameter	W/R	D7	D6	D5	D4	D3	D2	D1	D0	Default																										
0Eh	1st	R	D7	D6	0	0	0	0	0	D0	00h																										
Description	<p>0E: RDDSM (Read Display Signal Mode).</p> <p>This command indicates the current status of the display, as described in the table below:</p> <table border="1"> <thead> <tr> <th>Bit</th> <th>Description</th> <th>Value</th> <th>Status</th> </tr> </thead> <tbody> <tr> <td rowspan="2">D7</td> <td rowspan="2">Tearing Effect Line On/Off</td> <td>0</td> <td>Tearing Effect Line Off</td> </tr> <tr> <td>1</td> <td>Tearing Effect On</td> </tr> <tr> <td rowspan="2">D6</td> <td rowspan="2">Tearing Effect Line Output Mode</td> <td>0</td> <td>Tearing Effect Line Mode 1</td> </tr> <tr> <td>1</td> <td>Tearing Effect Line Mode 2</td> </tr> </tbody> </table> <table border="1"> <thead> <tr> <th>Bit</th> <th>Description</th> <th>Value</th> <th>Status</th> </tr> </thead> <tbody> <tr> <td rowspan="2">D0</td> <td rowspan="2">Error on DSI</td> <td>0</td> <td>No Error on DSI</td> </tr> <tr> <td>1</td> <td>Error on DSI</td> </tr> </tbody> </table> <p>See also sections: "4.1.3.2.2 Acknowledge with Error Report (AwER)" and "5.3.3 Read Number of the Errors on DSI (05h)".</p> <p><i>Note: For Bit D6, also refer to 5.3.21 Tearing Effect Line On (35h).</i></p>											Bit	Description	Value	Status	D7	Tearing Effect Line On/Off	0	Tearing Effect Line Off	1	Tearing Effect On	D6	Tearing Effect Line Output Mode	0	Tearing Effect Line Mode 1	1	Tearing Effect Line Mode 2	Bit	Description	Value	Status	D0	Error on DSI	0	No Error on DSI	1	Error on DSI
	Bit	Description	Value	Status																																	
	D7	Tearing Effect Line On/Off	0	Tearing Effect Line Off																																	
1			Tearing Effect On																																		
D6	Tearing Effect Line Output Mode	0	Tearing Effect Line Mode 1																																		
		1	Tearing Effect Line Mode 2																																		
Bit	Description	Value	Status																																		
D0	Error on DSI	0	No Error on DSI																																		
		1	Error on DSI																																		
Restriction	None																																				
Register Availability	<table border="1"> <thead> <tr> <th>Status</th> <th>Availability</th> </tr> </thead> <tbody> <tr> <td>Normal Mode On, Idle Mode Off, Sleep Out</td> <td>Yes</td> </tr> <tr> <td>Normal Mode On, Idle Mode On, Sleep Out</td> <td>Yes</td> </tr> <tr> <td>Sleep In</td> <td>Yes</td> </tr> </tbody> </table>											Status	Availability	Normal Mode On, Idle Mode Off, Sleep Out	Yes	Normal Mode On, Idle Mode On, Sleep Out	Yes	Sleep In	Yes																		
Status	Availability																																				
Normal Mode On, Idle Mode Off, Sleep Out	Yes																																				
Normal Mode On, Idle Mode On, Sleep Out	Yes																																				
Sleep In	Yes																																				
Default	<table border="1"> <thead> <tr> <th>Status</th> <th>Default Value</th> </tr> </thead> <tbody> <tr> <td>Power On Sequence</td> <td>00h</td> </tr> <tr> <td>S/W Reset</td> <td>00h</td> </tr> <tr> <td>H/W Reset</td> <td>00h</td> </tr> </tbody> </table>											Status	Default Value	Power On Sequence	00h	S/W Reset	00h	H/W Reset	00h																		
Status	Default Value																																				
Power On Sequence	00h																																				
S/W Reset	00h																																				
H/W Reset	00h																																				
Flow Chart	<pre> graph TD Host[Host] --> Read[Read RDDSM] Read --> Display[Display] Display --> Send[/Send Parameter/] </pre> <p>Legend:</p> <ul style="list-style-type: none"> Command: Rectangle Parameter: Parallelogram Display: Oval Action: Diamond Mode: Rounded Rectangle Sequential transfer: Cloud 																																				

5.3.10. Read Display Self-Diagnostic Result (0Fh)

Command Page		Page 0																				
Address	Parameter	W/R	D7	D6	D5	D4	D3	D2	D1	D0	Default											
0Fh	1st	R	D7	D6	0	0	0	0	0	D0	00h											
Description	0F: RDDSDR (Read Display Self-Diagnostic Result). This command indicates the status of the display self-diagnostic results after the Sleep Out command, as described in the table below:																					
	<table border="1"> <thead> <tr> <th>Bit</th> <th>Description</th> <th>Action</th> </tr> </thead> <tbody> <tr> <td>D7</td> <td>Register Loading Detection</td> <td>Invert the D7 bit when the EEPROM and register values are the same.</td> </tr> <tr> <td>D6</td> <td>Functionality Detection</td> <td>Invert the D6 bit when the chip meets user's functionality requirements.</td> </tr> <tr> <td>D0</td> <td>Checksums Comparison</td> <td>0 = Checksums are the same 1 = Checksums are not the same</td> </tr> </tbody> </table>											Bit	Description	Action	D7	Register Loading Detection	Invert the D7 bit when the EEPROM and register values are the same.	D6	Functionality Detection	Invert the D6 bit when the chip meets user's functionality requirements.	D0	Checksums Comparison
Bit	Description	Action																				
D7	Register Loading Detection	Invert the D7 bit when the EEPROM and register values are the same.																				
D6	Functionality Detection	Invert the D6 bit when the chip meets user's functionality requirements.																				
D0	Checksums Comparison	0 = Checksums are the same 1 = Checksums are not the same																				
Restriction	It will be necessary to wait 300ms after there is the last write access on Page 0 area registers before there can read Bit D0 value.																					
Register Availability	<table border="1"> <thead> <tr> <th>Status</th> <th>Availability</th> </tr> </thead> <tbody> <tr> <td>Normal Mode On, Idle Mode Off, Sleep Out</td> <td>Yes</td> </tr> <tr> <td>Normal Mode On, Idle Mode On, Sleep Out</td> <td>Yes</td> </tr> <tr> <td>Sleep In</td> <td>Yes</td> </tr> </tbody> </table>											Status	Availability	Normal Mode On, Idle Mode Off, Sleep Out	Yes	Normal Mode On, Idle Mode On, Sleep Out	Yes	Sleep In	Yes			
Status	Availability																					
Normal Mode On, Idle Mode Off, Sleep Out	Yes																					
Normal Mode On, Idle Mode On, Sleep Out	Yes																					
Sleep In	Yes																					
Default	<table border="1"> <thead> <tr> <th>Status</th> <th>Default Value</th> </tr> </thead> <tbody> <tr> <td>Power On Sequence</td> <td>00h</td> </tr> <tr> <td>S/W Reset</td> <td>00h</td> </tr> <tr> <td>H/W Reset</td> <td>00h</td> </tr> </tbody> </table>											Status	Default Value	Power On Sequence	00h	S/W Reset	00h	H/W Reset	00h			
Status	Default Value																					
Power On Sequence	00h																					
S/W Reset	00h																					
H/W Reset	00h																					
Flow Chart	<pre> graph TD subgraph Host C[Read RDDSDR] end subgraph Display P[/Send Parameter/] end C --> P </pre>																					

5.3.11. Sleep In (10h)

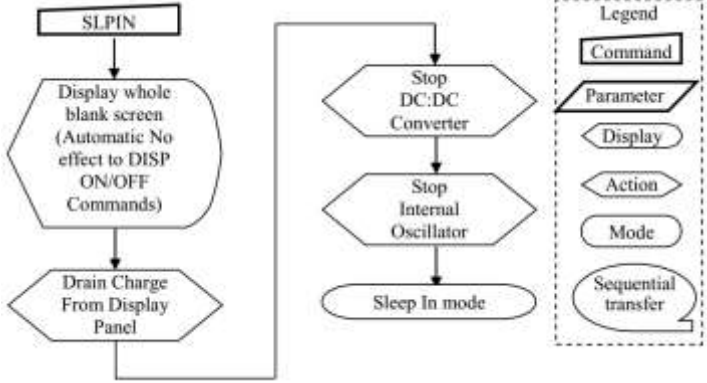
Command Page			Page 0																
Address	Parameter	W/R	D7	D6	D5	D4	D3	D2	D1	D0	Default								
10h	-	W	No Argument									-							
Description	<p>10h: SLPIN (Sleep In). This command causes the ILI9881C-0D to enter the minimum power consumption mode. In this mode, the DC/DC converter, Internal oscillator, and panel scanning are all stopped.</p>  <p>MCU interface and memory are still working and the memory can keep its contents. Ambient light based control is off. Backlights and display are off. Dimming function does not work when there is changing mode from Sleep Out to Sleep In.</p>																		
Restriction	<p>This command has no effect when the module is already in the Sleep In mode. To leave the Sleep In Mode, only the Sleep Out Command (11h) is workable. It is necessary to wait 5msec before sending the next command; this is to allow time for the supply voltages and clock circuits to become stable. It is necessary to wait 120msec after sending the Sleep Out command (when in the Sleep In Mode) before the Sleep In command can be sent.</p>																		
Register Availability	<table border="1"> <thead> <tr> <th>Status</th> <th>Availability</th> </tr> </thead> <tbody> <tr> <td>Normal Mode On, Idle Mode Off, Sleep Out</td> <td>Yes</td> </tr> <tr> <td>Normal Mode On, Idle Mode On, Sleep Out</td> <td>Yes</td> </tr> <tr> <td>Sleep In</td> <td>Yes</td> </tr> </tbody> </table>											Status	Availability	Normal Mode On, Idle Mode Off, Sleep Out	Yes	Normal Mode On, Idle Mode On, Sleep Out	Yes	Sleep In	Yes
Status	Availability																		
Normal Mode On, Idle Mode Off, Sleep Out	Yes																		
Normal Mode On, Idle Mode On, Sleep Out	Yes																		
Sleep In	Yes																		
Default	<table border="1"> <thead> <tr> <th>Status</th> <th>Default Value</th> </tr> </thead> <tbody> <tr> <td>Power On Sequence</td> <td>Sleep In Mode</td> </tr> <tr> <td>S/W Reset</td> <td>Sleep In Mode</td> </tr> <tr> <td>H/W Reset</td> <td>Sleep In Mode</td> </tr> </tbody> </table>											Status	Default Value	Power On Sequence	Sleep In Mode	S/W Reset	Sleep In Mode	H/W Reset	Sleep In Mode
Status	Default Value																		
Power On Sequence	Sleep In Mode																		
S/W Reset	Sleep In Mode																		
H/W Reset	Sleep In Mode																		
Flow Chart	<p>It takes 120msec to get into Sleep In mode after SLPIN command issued.</p>  <p>Legend Command Parameter Display Action Mode Sequential transfer</p>																		

5.3.12. Sleep Out (11h)

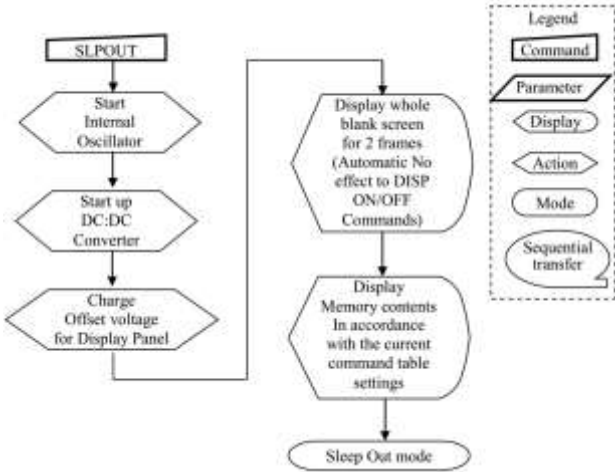
Command Page			Page 0																
Address	Parameter	W/R	D7	D6	D5	D4	D3	D2	D1	D0	Default								
11h	-	W	No Argument									-							
Description	<p>11h: SLPOUT (Sleep Out). This command turns off the sleep mode. In this mode, the DC/DC converter is enabled, the Internal oscillator is started, and the panel scanning is started.</p> 																		
Restriction	<p>This command has no effect when the module is already in the Sleep Out mode. To leave the Sleep Out mode, only the Sleep In command (10h), SW Reset Command (01h) or HW Reset are workable. It is necessary to wait 5msec before sending the next command; this is to allow time for the supply voltages and clock circuits to become stable.</p> <p>The Driver IC loads all display supplier's factory default values to the registers during this 5msec. There cannot be any abnormal visual effect on the display image if factory default and register values are the same when this load is done and when the Driver IC is already in the Sleep Out mode. During this 5msec, the Driver IC also performs self-diagnostic functions.</p> <p>It is necessary to wait 120msec after sending the Sleep In command (when in the Sleep Out mode) before the Sleep Out command can be sent.</p>																		
Register Availability	<table border="1"> <thead> <tr> <th>Status</th> <th>Availability</th> </tr> </thead> <tbody> <tr> <td>Normal Mode On, Idle Mode Off, Sleep Out</td> <td>Yes</td> </tr> <tr> <td>Normal Mode On, Idle Mode On, Sleep Out</td> <td>Yes</td> </tr> <tr> <td>Sleep In</td> <td>Yes</td> </tr> </tbody> </table>											Status	Availability	Normal Mode On, Idle Mode Off, Sleep Out	Yes	Normal Mode On, Idle Mode On, Sleep Out	Yes	Sleep In	Yes
Status	Availability																		
Normal Mode On, Idle Mode Off, Sleep Out	Yes																		
Normal Mode On, Idle Mode On, Sleep Out	Yes																		
Sleep In	Yes																		
Default	<table border="1"> <thead> <tr> <th>Status</th> <th>Default Value</th> </tr> </thead> <tbody> <tr> <td>Power On Sequence</td> <td>Sleep In Mode</td> </tr> <tr> <td>S/W Reset</td> <td>Sleep In Mode</td> </tr> <tr> <td>H/W Reset</td> <td>Sleep In Mode</td> </tr> </tbody> </table>											Status	Default Value	Power On Sequence	Sleep In Mode	S/W Reset	Sleep In Mode	H/W Reset	Sleep In Mode
Status	Default Value																		
Power On Sequence	Sleep In Mode																		
S/W Reset	Sleep In Mode																		
H/W Reset	Sleep In Mode																		
Flow Chart	<p>It takes 120msec to become Sleep Out mode after SLPOUT command issued.</p> 																		

5.3.13. Normal Display Mode On (13h)

Command Page			Page 0																
Address	Parameter	W/R	D7	D6	D5	D4	D3	D2	D1	D0	Default								
13h	-	W	No Argument									-							
Description		13h: NORON (Normal Display Mode On). This command returns the display to normal mode.																	
Restriction		This command has no effect when the Normal Display Mode is active.																	
Register Availability		<table border="1"> <thead> <tr> <th>Status</th> <th>Availability</th> </tr> </thead> <tbody> <tr> <td>Normal Mode On, Idle Mode Off, Sleep Out</td> <td>Yes</td> </tr> <tr> <td>Normal Mode On, Idle Mode On, Sleep Out</td> <td>Yes</td> </tr> <tr> <td>Sleep In</td> <td>Yes</td> </tr> </tbody> </table>										Status	Availability	Normal Mode On, Idle Mode Off, Sleep Out	Yes	Normal Mode On, Idle Mode On, Sleep Out	Yes	Sleep In	Yes
Status	Availability																		
Normal Mode On, Idle Mode Off, Sleep Out	Yes																		
Normal Mode On, Idle Mode On, Sleep Out	Yes																		
Sleep In	Yes																		
Default		<table border="1"> <thead> <tr> <th>Status</th> <th>Default Value</th> </tr> </thead> <tbody> <tr> <td>Power On Sequence</td> <td>Normal Display Mode On</td> </tr> <tr> <td>S/W Reset</td> <td>Normal Display Mode On</td> </tr> <tr> <td>H/W Reset</td> <td>Normal Display Mode On</td> </tr> </tbody> </table>										Status	Default Value	Power On Sequence	Normal Display Mode On	S/W Reset	Normal Display Mode On	H/W Reset	Normal Display Mode On
Status	Default Value																		
Power On Sequence	Normal Display Mode On																		
S/W Reset	Normal Display Mode On																		
H/W Reset	Normal Display Mode On																		
Flow Chart																			

5.3.14. All Pixel Off (22h)

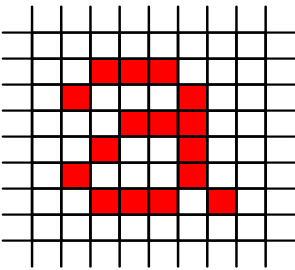
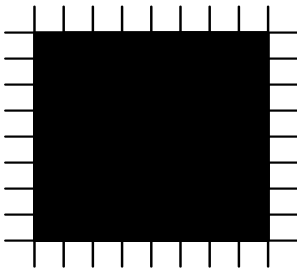
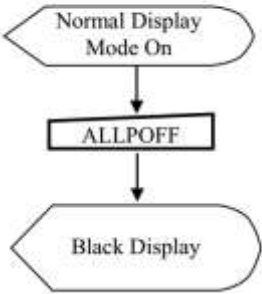
Command Page			Page 0																
Address	Parameter	W/R	D7	D6	D5	D4	D3	D2	D1	D0	Default								
22h	-	W	No Argument									-							
Description	<p>22h: ALLPOFF (All Pixels Off).</p> <p>This command turns the display panel black in 'Sleep Out' mode and a status bit of the 'Read Display Image Mode' register (0Dh) can be read.</p> <p>This command makes no change of contents of the input data (or frame memory). This command does not change any other status.</p>																		
	<div style="display: flex; justify-content: space-around; align-items: center;"> <div style="text-align: center;"> <p>Input Data/ Memory</p>  </div> <div style="font-size: 2em; margin: 0 20px;">→</div> <div style="text-align: center;"> <p>Display Panel</p>  </div> </div> <p>'All Pixels On' or 'Normal Display Mode On' commands are used to leave this mode. When ILI9881C-0D works in 'Idle Mode On' and 'Sleep Out' state, the display panel is showing the content of the frame memory after 'Normal Display Mode On' commands.</p>																		
Restriction	This command has no effect when module is already in all pixels off mode.																		
Register Availability	<table border="1" style="margin-left: auto; margin-right: auto;"> <thead> <tr> <th>Status</th> <th>Availability</th> </tr> </thead> <tbody> <tr> <td>Normal Mode On, Idle Mode Off, Sleep Out</td> <td>Yes</td> </tr> <tr> <td>Normal Mode On, Idle Mode On, Sleep Out</td> <td>Yes</td> </tr> <tr> <td>Sleep In</td> <td>Yes</td> </tr> </tbody> </table>											Status	Availability	Normal Mode On, Idle Mode Off, Sleep Out	Yes	Normal Mode On, Idle Mode On, Sleep Out	Yes	Sleep In	Yes
Status	Availability																		
Normal Mode On, Idle Mode Off, Sleep Out	Yes																		
Normal Mode On, Idle Mode On, Sleep Out	Yes																		
Sleep In	Yes																		
Default	<table border="1" style="margin-left: auto; margin-right: auto;"> <thead> <tr> <th>Status</th> <th>Default Value</th> </tr> </thead> <tbody> <tr> <td>Power On Sequence</td> <td>OFF</td> </tr> <tr> <td>S/W Reset</td> <td>OFF</td> </tr> <tr> <td>H/W Reset</td> <td>OFF</td> </tr> </tbody> </table>											Status	Default Value	Power On Sequence	OFF	S/W Reset	OFF	H/W Reset	OFF
Status	Default Value																		
Power On Sequence	OFF																		
S/W Reset	OFF																		
H/W Reset	OFF																		
Flow Chart	<div style="display: flex; justify-content: space-between; align-items: center;"> <div style="text-align: center;">  </div> <div style="border: 1px dashed gray; padding: 5px;"> <p>Legend</p> <ul style="list-style-type: none"> Command: [Rectangle] Parameter: [Trapezoid] Display: [Oval] Action: [Hexagon] Mode: [Circle] Sequential transfer: [Speech bubble] </div> </div>																		



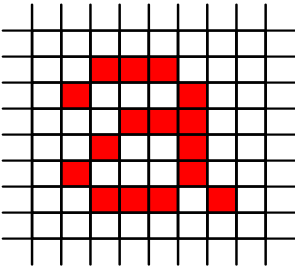
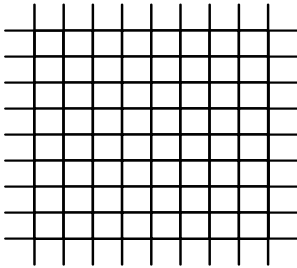

5.3.15. All Pixel On (23h)

Command Page			Page 0																
Address	Parameter	W/R	D7	D6	D5	D4	D3	D2	D1	D0	Default								
23h	-	W	No Argument									-							
Description	<p>23h: ALLPON (All Pixels On).</p> <p>This command turns the display panel white in 'Sleep out' mode and a status bit of the 'Read Display Image Mode' register (0Dh) can be read.</p> <p>This command makes no change of contents of the input data (or frame memory). This command does not change any other status.</p> <div style="display: flex; justify-content: space-around; align-items: center;"> <div style="text-align: center;"> <p>Input Data/ Memory</p>  </div> <div style="font-size: 2em;">→</div> <div style="text-align: center;"> <p>Display Panel</p>  </div> </div> <p>'All Pixels Off' or 'Normal Display Mode On' commands are used to leave this mode.</p> <p>When ILI9881C-0D works in 'Idle Mode On' and 'Sleep Out' state, the display panel is showing the content of the frame memory after 'Normal Display Mode On' commands.</p>																		
	Restriction	This command has no effect when module is already in all pixels on mode.																	
Register Availability	<table border="1" style="margin-left: auto; margin-right: auto;"> <thead> <tr> <th>Status</th> <th>Availability</th> </tr> </thead> <tbody> <tr> <td>Normal Mode On, Idle Mode Off, Sleep Out</td> <td>Yes</td> </tr> <tr> <td>Normal Mode On, Idle Mode On, Sleep Out</td> <td>Yes</td> </tr> <tr> <td>Sleep In</td> <td>Yes</td> </tr> </tbody> </table>											Status	Availability	Normal Mode On, Idle Mode Off, Sleep Out	Yes	Normal Mode On, Idle Mode On, Sleep Out	Yes	Sleep In	Yes
Status	Availability																		
Normal Mode On, Idle Mode Off, Sleep Out	Yes																		
Normal Mode On, Idle Mode On, Sleep Out	Yes																		
Sleep In	Yes																		
Default	<table border="1" style="margin-left: auto; margin-right: auto;"> <thead> <tr> <th>Status</th> <th>Default Value</th> </tr> </thead> <tbody> <tr> <td>Power On Sequence</td> <td>OFF</td> </tr> <tr> <td>S/W Reset</td> <td>OFF</td> </tr> <tr> <td>H/W Reset</td> <td>OFF</td> </tr> </tbody> </table>											Status	Default Value	Power On Sequence	OFF	S/W Reset	OFF	H/W Reset	OFF
Status	Default Value																		
Power On Sequence	OFF																		
S/W Reset	OFF																		
H/W Reset	OFF																		
Flow Chart	<div style="display: flex; align-items: center; justify-content: center;"> <div style="text-align: center; margin-right: 20px;"> <p>Normal Display Mode On</p> ↓ <p>ALLPON</p> ↓ <p>White Display</p> </div> <div style="border: 1px dashed black; padding: 5px;"> <p>Legend</p> <ul style="list-style-type: none"> Command Parameter Display Action Mode Sequential transfer </div> </div>																		

5.3.16. Gamma Set (26h)

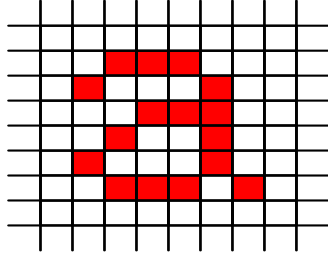
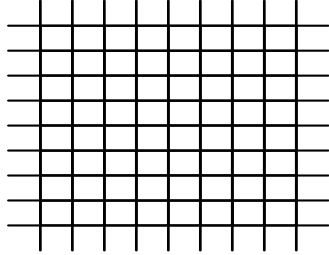
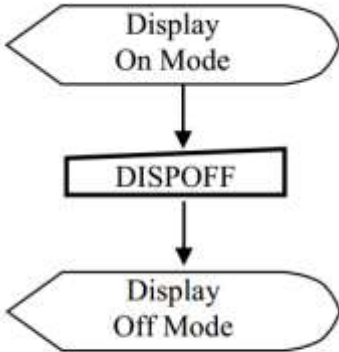
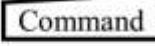
Command Page		Page 0																	
Address	Parameter	W/R	D7	D6	D5	D4	D3	D2	D1	D0	Default								
26h	1st	W	0	0	0	0	GC [3:0]				01h								
Description	<p>26h: GAMSET (Gamma Set).</p> <p>This command is used to select the desired Gamma curve for the current display. A maximum of 1 fixed Gamma curves can be selected. The curve is selected by setting the appropriate bit in the parameter as described in the Table below:</p> <table border="1" style="margin-left: auto; margin-right: auto;"> <thead> <tr> <th>GC [3:0]</th> <th>Curve Selected</th> </tr> </thead> <tbody> <tr> <td>1h</td> <td>Gamma curve 1</td> </tr> <tr> <td>Other</td> <td>Reserved</td> </tr> </tbody> </table> <p><i>Note: All others value are undefined.</i></p>											GC [3:0]	Curve Selected	1h	Gamma curve 1	Other	Reserved		
GC [3:0]	Curve Selected																		
1h	Gamma curve 1																		
Other	Reserved																		
Restriction	<p>Values of GC [3:0] not shown in the table above are invalid and will not change the current selected Gamma curve until a valid value is received.</p>																		
Register Availability	<table border="1" style="margin-left: auto; margin-right: auto;"> <thead> <tr> <th>Status</th> <th>Availability</th> </tr> </thead> <tbody> <tr> <td>Normal Mode On, Idle Mode Off, Sleep Out</td> <td>Yes</td> </tr> <tr> <td>Normal Mode On, Idle Mode On, Sleep Out</td> <td>Yes</td> </tr> <tr> <td>Sleep In</td> <td>Yes</td> </tr> </tbody> </table>											Status	Availability	Normal Mode On, Idle Mode Off, Sleep Out	Yes	Normal Mode On, Idle Mode On, Sleep Out	Yes	Sleep In	Yes
Status	Availability																		
Normal Mode On, Idle Mode Off, Sleep Out	Yes																		
Normal Mode On, Idle Mode On, Sleep Out	Yes																		
Sleep In	Yes																		
Default	<table border="1" style="margin-left: auto; margin-right: auto;"> <thead> <tr> <th>Status</th> <th>Default Value</th> </tr> </thead> <tbody> <tr> <td>Power On Sequence</td> <td>01h</td> </tr> <tr> <td>S/W Reset</td> <td>01h</td> </tr> <tr> <td>H/W Reset</td> <td>01h</td> </tr> </tbody> </table>											Status	Default Value	Power On Sequence	01h	S/W Reset	01h	H/W Reset	01h
Status	Default Value																		
Power On Sequence	01h																		
S/W Reset	01h																		
H/W Reset	01h																		
Flow Chart	<div style="border: 1px dashed black; padding: 10px;"> <p style="text-align: center;">Legend</p> <ul style="list-style-type: none"> Command Parameter Display Action Mode Sequential transfer <div style="margin-top: 20px; text-align: center;"> <pre> graph TD A[GAMSET] --> B[/GC[7..0]/] B --> C[/New Gamma Curve Loaded/] </pre> </div> </div>																		

5.3.17. Display Off (28h)

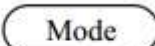
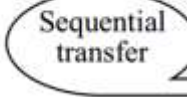
Command Page		Page 0																	
Address	Parameter	W/R	D7	D6	D5	D4	D3	D2	D1	D0	Default								
28h	-	W	No Argument									-							
Description	<p>28h: DISPOFF (Display Off)</p> <p>This command is used to enter into the Display Off mode. Output from the input data (or frame memory) is disabled and a blank page inserted. This command makes no change of contents of the input data (or frame memory) and does not change any other status. There will be no abnormal visible effect on the display.</p>																		
	<div style="display: flex; justify-content: space-around; align-items: center;"> <div style="text-align: center;"> <p>Input Data/ Memory</p>  </div> <div style="font-size: 2em; margin: 0 20px;">→</div> <div style="text-align: center;"> <p>Display Panel</p>  </div> </div>																		
Restriction	This command has no effect when the module is already in the Display Off mode.																		
Register Availability	<table border="1" style="margin-left: auto; margin-right: auto;"> <thead> <tr> <th>Status</th> <th>Availability</th> </tr> </thead> <tbody> <tr> <td>Normal Mode On, Idle Mode Off, Sleep Out</td> <td>Yes</td> </tr> <tr> <td>Normal Mode On, Idle Mode On, Sleep Out</td> <td>Yes</td> </tr> <tr> <td>Sleep In</td> <td>Yes</td> </tr> </tbody> </table>											Status	Availability	Normal Mode On, Idle Mode Off, Sleep Out	Yes	Normal Mode On, Idle Mode On, Sleep Out	Yes	Sleep In	Yes
Status	Availability																		
Normal Mode On, Idle Mode Off, Sleep Out	Yes																		
Normal Mode On, Idle Mode On, Sleep Out	Yes																		
Sleep In	Yes																		
Default	<table border="1" style="margin-left: auto; margin-right: auto;"> <thead> <tr> <th>Status</th> <th>Default Value</th> </tr> </thead> <tbody> <tr> <td>Power On Sequence</td> <td>Display Off</td> </tr> <tr> <td>S/W Reset</td> <td>Display Off</td> </tr> <tr> <td>H/W Reset</td> <td>Display Off</td> </tr> </tbody> </table>											Status	Default Value	Power On Sequence	Display Off	S/W Reset	Display Off	H/W Reset	Display Off
Status	Default Value																		
Power On Sequence	Display Off																		
S/W Reset	Display Off																		
H/W Reset	Display Off																		
Flow Chart	<div style="display: flex; justify-content: space-around; align-items: center;"> <div style="text-align: center;">  </div> <div style="border: 1px dashed black; padding: 5px;"> <p>Legend</p> <ul style="list-style-type: none">  Command  Parameter  Display  Action  Mode  Sequential transfer </div> </div>																		

5.3.18. Display ON (29h)

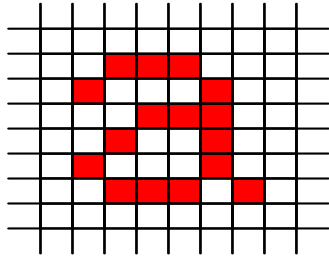
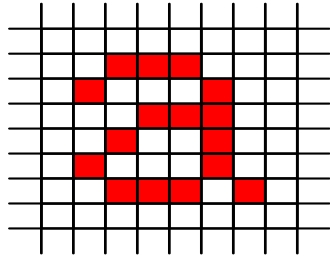
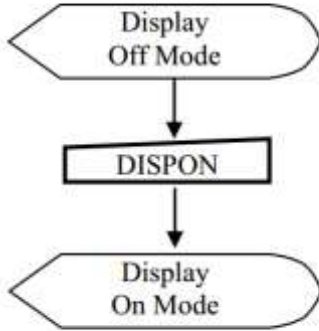
Command Page		Page 0																	
Address	Parameter	W/R	D7	D6	D5	D4	D3	D2	D1	D0	Default								
29h	-	W	No Argument									-							
Description	<p>29h: DISPON (Display On).</p> <p>This command is used to recover from the Display Off mode. Output from the input data (or frame memory) is enabled. This command makes no change of contents of the input data (or frame memory) and does not change any other status.</p>																		
	<div style="display: flex; justify-content: space-around; align-items: center;"> <div style="text-align: center;"> <p>Input Data/ Memory</p>  </div> <div style="font-size: 2em; margin: 0 20px;">→</div> <div style="text-align: center;"> <p>Display Panel</p>  </div> </div>																		
Restriction	This command has no effect when the ILI9881C-0D is already in the Display On mode.																		
Register Availability	<table border="1" style="margin-left: auto; margin-right: auto;"> <thead> <tr> <th>Status</th> <th>Availability</th> </tr> </thead> <tbody> <tr> <td>Normal Mode On, Idle Mode Off, Sleep Out</td> <td>Yes</td> </tr> <tr> <td>Normal Mode On, Idle Mode On, Sleep Out</td> <td>Yes</td> </tr> <tr> <td>Sleep In</td> <td>Yes</td> </tr> </tbody> </table>											Status	Availability	Normal Mode On, Idle Mode Off, Sleep Out	Yes	Normal Mode On, Idle Mode On, Sleep Out	Yes	Sleep In	Yes
Status	Availability																		
Normal Mode On, Idle Mode Off, Sleep Out	Yes																		
Normal Mode On, Idle Mode On, Sleep Out	Yes																		
Sleep In	Yes																		
Default	<table border="1" style="margin-left: auto; margin-right: auto;"> <thead> <tr> <th>Status</th> <th>Default Value</th> </tr> </thead> <tbody> <tr> <td>Power On Sequence</td> <td>Display Off</td> </tr> <tr> <td>S/W Reset</td> <td>Display Off</td> </tr> <tr> <td>H/W Reset</td> <td>Display Off</td> </tr> </tbody> </table>											Status	Default Value	Power On Sequence	Display Off	S/W Reset	Display Off	H/W Reset	Display Off
Status	Default Value																		
Power On Sequence	Display Off																		
S/W Reset	Display Off																		
H/W Reset	Display Off																		
Flow Chart	<div style="display: flex; align-items: center; justify-content: center;"> <div style="text-align: center; margin-right: 20px;">  <pre> graph TD A[Display Off Mode] --> B[DISPON] B --> C[Display On Mode] </pre> </div> <div style="border: 1px dashed black; padding: 5px;"> <p>Legend</p> <ul style="list-style-type: none"> Command Parameter Display Action Mode Sequential transfer </div> </div>																		

5.3.19. Memory Write (2Ch)

Command Page			Page 0																
Address	Parameter	W/R	D7	D6	D5	D4	D3	D2	D1	D0	Default								
2Ch	1st	W	D1[23:16]								00~FFh								
	2nd	W	D1[15:8]								00~FFh								
	3rd	W	D1[7:0]								00~FFh								
	...	W	...								00~FFh								
	Nth	W	Dn[7:0]								00~FFh								
Description	<p>2Ch: RAMWR (Memory Write).</p> <p>This command transfers data from the MCU to the Frame Memory. This command makes no change to the other driver status. When this command is accepted, the column register and the page register are reset to zero. Then D[23:0] is stored in the Frame Memory and the column register and the page register incremented at the same time. Sending any other command can stop frame Write.</p>																		
Restriction	<p>This command's parameter length must be based on 2 pixel data length (6 bytes) (N=3 x n, N is multiple of 6).</p> <p>When ILI9881C-0D's work state is "Normal Mode On, Idle Mode On and Sleep Out", full-resolution frame data must be send by Memory Write (2Ch) and Memory Write Continue (3Ch) command.</p> <p>Transmission sequences: LP_00 → HS for R2Ch → LP_00 → HS for R3Ch → LP_00 → HS for CMD → LP_00</p>																		
Register Availability	<table border="1"> <thead> <tr> <th>Status</th> <th>Availability</th> </tr> </thead> <tbody> <tr> <td>Normal Mode On, Idle Mode Off, Sleep Out</td> <td>Yes</td> </tr> <tr> <td>Normal Mode On, Idle Mode On, Sleep Out</td> <td>Yes</td> </tr> <tr> <td>Sleep In</td> <td>Yes</td> </tr> </tbody> </table>											Status	Availability	Normal Mode On, Idle Mode Off, Sleep Out	Yes	Normal Mode On, Idle Mode On, Sleep Out	Yes	Sleep In	Yes
Status	Availability																		
Normal Mode On, Idle Mode Off, Sleep Out	Yes																		
Normal Mode On, Idle Mode On, Sleep Out	Yes																		
Sleep In	Yes																		
Default	<table border="1"> <thead> <tr> <th>Status</th> <th>Default Value</th> </tr> </thead> <tbody> <tr> <td>Power On Sequence</td> <td>Contents of memory is set randomly</td> </tr> <tr> <td>S/W Reset</td> <td>Contents of memory is set randomly</td> </tr> <tr> <td>H/W Reset</td> <td>Contents of memory is set randomly</td> </tr> </tbody> </table>											Status	Default Value	Power On Sequence	Contents of memory is set randomly	S/W Reset	Contents of memory is set randomly	H/W Reset	Contents of memory is set randomly
Status	Default Value																		
Power On Sequence	Contents of memory is set randomly																		
S/W Reset	Contents of memory is set randomly																		
H/W Reset	Contents of memory is set randomly																		
Flow Chart	<pre> graph TD A[RAMWR] --> B(Image Data D1[23:0], D2[23:0], ..., Dn[23:0]) B --> C[Any Command] </pre> <p>Legend:</p> <ul style="list-style-type: none"> Command: Rectangle Parameter: Parallelogram Display: Oval Action: Arrow Mode: Rounded Rectangle Sequential transfer: Oval with tail 																		

5.3.20. Tearing Effect Line Off (34h)

Command Page			Page 0																
Address	Parameter	W/R	D7	D6	D5	D4	D3	D2	D1	D0	Default								
34h	-	W	No Argument									-							
Description	<p>34h: TEOFF (Tearing Effect Line OFF). This command is used to turn off the Display module's Tearing Effect output signal from the TE signal line.</p>																		
Restriction	This command has no effect when the Tearing Effect output is already off.																		
Register Availability	<table border="1"> <thead> <tr> <th>Status</th> <th>Availability</th> </tr> </thead> <tbody> <tr> <td>Normal Mode On, Idle Mode Off, Sleep Out</td> <td>Yes</td> </tr> <tr> <td>Normal Mode On, Idle Mode On, Sleep Out</td> <td>Yes</td> </tr> <tr> <td>Sleep In</td> <td>Yes</td> </tr> </tbody> </table>											Status	Availability	Normal Mode On, Idle Mode Off, Sleep Out	Yes	Normal Mode On, Idle Mode On, Sleep Out	Yes	Sleep In	Yes
Status	Availability																		
Normal Mode On, Idle Mode Off, Sleep Out	Yes																		
Normal Mode On, Idle Mode On, Sleep Out	Yes																		
Sleep In	Yes																		
Default	<table border="1"> <thead> <tr> <th>Status</th> <th>Default Value</th> </tr> </thead> <tbody> <tr> <td>Power On Sequence</td> <td>Off</td> </tr> <tr> <td>S/W Reset</td> <td>Off</td> </tr> <tr> <td>H/W Reset</td> <td>Off</td> </tr> </tbody> </table>											Status	Default Value	Power On Sequence	Off	S/W Reset	Off	H/W Reset	Off
Status	Default Value																		
Power On Sequence	Off																		
S/W Reset	Off																		
H/W Reset	Off																		
Flow Chart	<pre> graph TD A([TE Line Output ON]) --> B[TEOFF] B --> C([TE Line Output OFF]) </pre> <p>Legend</p> <ul style="list-style-type: none"> Command: Rectangle Parameter: Parallelogram Display: Trapezoid Action: Arrow Mode: Oval Sequential transfer: Oval with tail 																		

5.3.21. Tearing Effect Line On (35h)

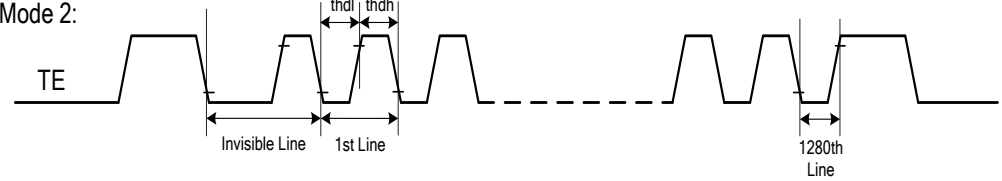
Command Page		Page 0																	
Address	Parameter	W/R	D7	D6	D5	D4	D3	D2	D1	D0	Default								
35h	1st	W	0	0	0	0	0	0	0	M	00								
Description	<p>35h: TEON (Tearing Effect Line ON).</p> <p>This command is used to turn on the Tearing Effect output signal from the TE signal line. The Tearing Effect Line On has one parameter which describes the mode of the Tearing Effect Output Line.</p> <p>When M=0: The Tearing Effect Output line consists of V-Blanking information only:</p> <p style="text-align: center;">Mode 1:</p>  <p style="text-align: center;">When M=1: The Tearing Effect Output Line consists of both V-Blanking and H-Blanking information:</p> <p style="text-align: center;">Mode 2:</p>  <p><i>Note : The Tearing Effect Output line shall be low when the display module is in Sleep mode</i></p>																		
	Restriction	This command has no effect when the Tearing Effect output is already ON.																	
Register Availability	<table border="1" style="margin-left: auto; margin-right: auto;"> <thead> <tr> <th>Status</th> <th>Availability</th> </tr> </thead> <tbody> <tr> <td>Normal Mode On, Idle Mode Off, Sleep Out</td> <td>Yes</td> </tr> <tr> <td>Normal Mode On, Idle Mode On, Sleep Out</td> <td>Yes</td> </tr> <tr> <td>Sleep In</td> <td>Yes</td> </tr> </tbody> </table>											Status	Availability	Normal Mode On, Idle Mode Off, Sleep Out	Yes	Normal Mode On, Idle Mode On, Sleep Out	Yes	Sleep In	Yes
Status	Availability																		
Normal Mode On, Idle Mode Off, Sleep Out	Yes																		
Normal Mode On, Idle Mode On, Sleep Out	Yes																		
Sleep In	Yes																		
Default	<table border="1" style="margin-left: auto; margin-right: auto;"> <thead> <tr> <th>Status</th> <th>Default Value</th> </tr> </thead> <tbody> <tr> <td>Power On Sequence</td> <td>Off</td> </tr> <tr> <td>S/W Reset</td> <td>Off</td> </tr> <tr> <td>H/W Reset</td> <td>Off</td> </tr> </tbody> </table>											Status	Default Value	Power On Sequence	Off	S/W Reset	Off	H/W Reset	Off
Status	Default Value																		
Power On Sequence	Off																		
S/W Reset	Off																		
H/W Reset	Off																		

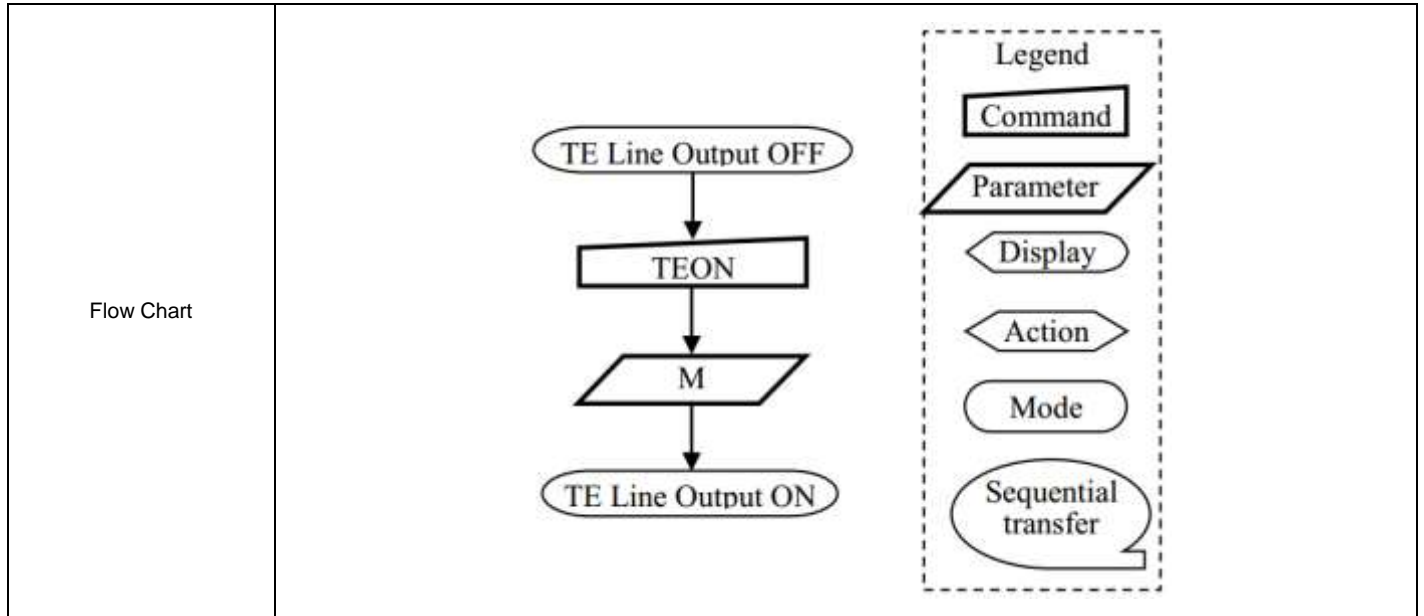

5.3.22. Memory Access Control (36h)

Command Page		Page 0																									
Address	Parameter	W/R	D7	D6	D5	D4	D3	D2	D1	D0	Default																
36h	1st	W	0	0	0	0	BGR	0	SS	GS	00h																
Description		36h: MADCTL (Memory Access Control).																									
		This command makes no change on the other status of the driver.																									
		<table border="1"> <thead> <tr> <th>Bit</th> <th>Symbol</th> <th>Name</th> <th>Description</th> </tr> </thead> <tbody> <tr> <td>D3</td> <td>BGR</td> <td>RGB/BGR Order</td> <td>Color selector switch control (0=RGB color filter panel, 1=BGR color filter panel)</td> </tr> <tr> <td>D1</td> <td>SS</td> <td>Flip Horizontal (SS)</td> <td>Select the Source driver scan direction on the panel module</td> </tr> <tr> <td>D0</td> <td>GS</td> <td>Flip Vertical (GS)</td> <td>Select the Gate driver scan direction on the panel module</td> </tr> </tbody> </table>										Bit	Symbol	Name	Description	D3	BGR	RGB/BGR Order	Color selector switch control (0=RGB color filter panel, 1=BGR color filter panel)	D1	SS	Flip Horizontal (SS)	Select the Source driver scan direction on the panel module	D0	GS	Flip Vertical (GS)	Select the Gate driver scan direction on the panel module
		Bit	Symbol	Name	Description																						
		D3	BGR	RGB/BGR Order	Color selector switch control (0=RGB color filter panel, 1=BGR color filter panel)																						
		D1	SS	Flip Horizontal (SS)	Select the Source driver scan direction on the panel module																						
		D0	GS	Flip Vertical (GS)	Select the Gate driver scan direction on the panel module																						
		BGR (RGB-BGR Order control bit)="0"					BGR (RGB-BGR Order control bit)="1"																				
		SS (Source Scan sequence)="0"					SS (Source Scan sequence)="1"																				
GS (Gate Scan sequence)="0"					GS (Gate Scan sequence)="1"																						
Restriction	None																										
Register Availability	<table border="1"> <thead> <tr> <th>Status</th> <th>Availability</th> </tr> </thead> <tbody> <tr> <td>Normal Mode On, Idle Mode Off, Sleep Out</td> <td>Yes</td> </tr> <tr> <td>Normal Mode On, Idle Mode On, Sleep Out</td> <td>Yes</td> </tr> <tr> <td>Sleep In</td> <td>Yes</td> </tr> </tbody> </table>											Status	Availability	Normal Mode On, Idle Mode Off, Sleep Out	Yes	Normal Mode On, Idle Mode On, Sleep Out	Yes	Sleep In	Yes								
Status	Availability																										
Normal Mode On, Idle Mode Off, Sleep Out	Yes																										
Normal Mode On, Idle Mode On, Sleep Out	Yes																										
Sleep In	Yes																										
Default	<table border="1"> <thead> <tr> <th>Status</th> <th>Default Value</th> </tr> </thead> <tbody> <tr> <td>Power On Sequence</td> <td>00h</td> </tr> <tr> <td>S/W Reset</td> <td>00h</td> </tr> <tr> <td>H/W Reset</td> <td>00h</td> </tr> </tbody> </table>											Status	Default Value	Power On Sequence	00h	S/W Reset	00h	H/W Reset	00h								
Status	Default Value																										
Power On Sequence	00h																										
S/W Reset	00h																										
H/W Reset	00h																										

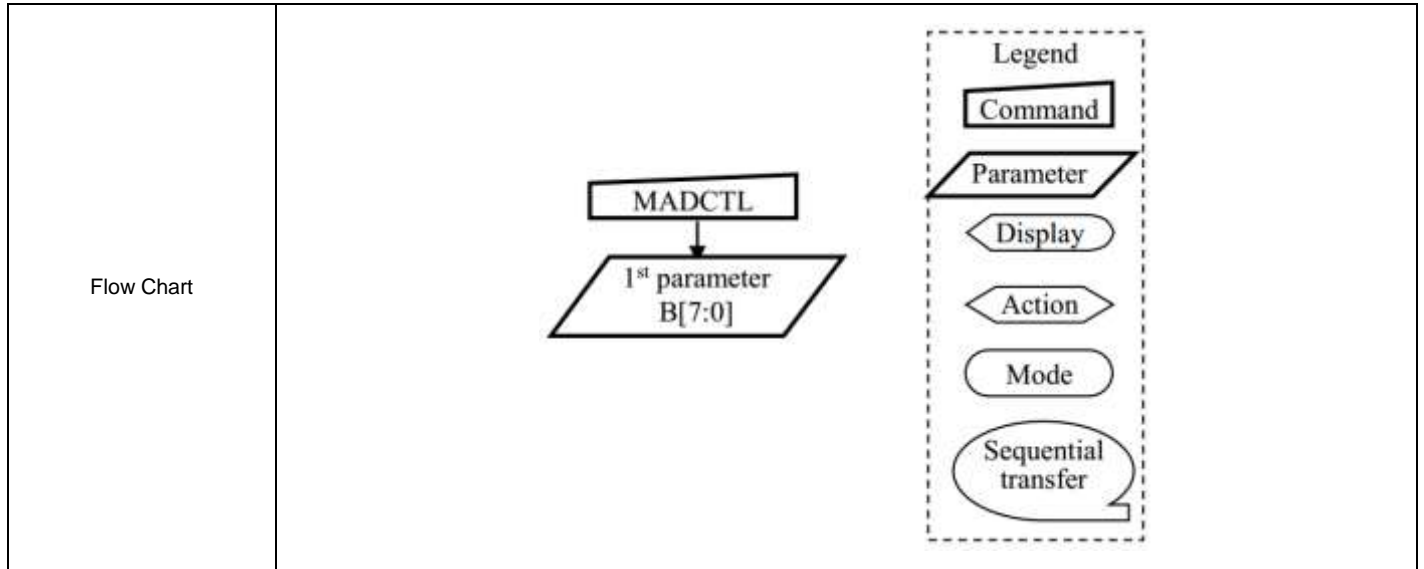

5.3.23. Idle Mode Off (38h)

Command Page			Page 0																
Address	Parameter	W/R	D7	D6	D5	D4	D3	D2	D1	D0	Default								
38h	-	W	No Argument									-							
Description	38h: IDMOFF (Idle mode off). This command causes the Display module to exit the Idle mode. In the Idle Mode Off, the display panel can display a maximum of 16.7M colors.																		
Restriction	This command has no effect when the module is already in the Idle Mode Off.																		
Register Availability	<table border="1"> <thead> <tr> <th>Status</th> <th>Availability</th> </tr> </thead> <tbody> <tr> <td>Normal Mode On, Idle Mode Off, Sleep Out</td> <td>Yes</td> </tr> <tr> <td>Normal Mode On, Idle Mode On, Sleep Out</td> <td>Yes</td> </tr> <tr> <td>Sleep In</td> <td>Yes</td> </tr> </tbody> </table>											Status	Availability	Normal Mode On, Idle Mode Off, Sleep Out	Yes	Normal Mode On, Idle Mode On, Sleep Out	Yes	Sleep In	Yes
Status	Availability																		
Normal Mode On, Idle Mode Off, Sleep Out	Yes																		
Normal Mode On, Idle Mode On, Sleep Out	Yes																		
Sleep In	Yes																		
Default	<table border="1"> <thead> <tr> <th>Status</th> <th>Default Value</th> </tr> </thead> <tbody> <tr> <td>Power On Sequence</td> <td>Idle Mode Off</td> </tr> <tr> <td>S/W Reset</td> <td>Idle Mode Off</td> </tr> <tr> <td>H/W Reset</td> <td>Idle Mode Off</td> </tr> </tbody> </table>											Status	Default Value	Power On Sequence	Idle Mode Off	S/W Reset	Idle Mode Off	H/W Reset	Idle Mode Off
Status	Default Value																		
Power On Sequence	Idle Mode Off																		
S/W Reset	Idle Mode Off																		
H/W Reset	Idle Mode Off																		
Flow Chart	<pre> graph TD A[Idle on mode] --> B[IDMOFF] B --> C[Idle off mode] </pre> <p>The flow chart illustrates the process of exiting Idle mode. It starts with 'Idle on mode' (a rounded rectangle), followed by the 'IDMOFF' command (a rectangle), and finally transitions to 'Idle off mode' (a rounded rectangle). A legend on the right defines the symbols used: a rectangle for 'Command', a parallelogram for 'Parameter', an oval for 'Display', an arrow for 'Action', a rounded rectangle for 'Mode', and a speech bubble for 'Sequential transfer'.</p>																		

5.3.24. Idle Mode On (39h)

Command Page			Page 0																
Address	Parameter	W/R	D7	D6	D5	D4	D3	D2	D1	D0	Default								
39h	-	W	No Argument									-							
Description	<p>39h: IDMON (Idle mode on).</p> <p>This command is used to enter into the Idle Mode On. In the Idle Mode On, color expression is reduced. The display panel shows de-compressed content of frame memory in the Idle Mode On and Sleep Out states. The primary color of "Normal Black" panel is black, the secondary color is defined by "Write Idle Mode Color" (80h) command.</p>																		
Restriction	This command has no effect when the module is already in the Idle Mode On.																		
Register Availability	<table border="1"> <thead> <tr> <th>Status</th> <th>Availability</th> </tr> </thead> <tbody> <tr> <td>Normal Mode On, Idle Mode Off, Sleep Out</td> <td>Yes</td> </tr> <tr> <td>Normal Mode On, Idle Mode On, Sleep Out</td> <td>Yes</td> </tr> <tr> <td>Sleep In</td> <td>Yes</td> </tr> </tbody> </table>											Status	Availability	Normal Mode On, Idle Mode Off, Sleep Out	Yes	Normal Mode On, Idle Mode On, Sleep Out	Yes	Sleep In	Yes
Status	Availability																		
Normal Mode On, Idle Mode Off, Sleep Out	Yes																		
Normal Mode On, Idle Mode On, Sleep Out	Yes																		
Sleep In	Yes																		
Default	<table border="1"> <thead> <tr> <th>Status</th> <th>Default Value</th> </tr> </thead> <tbody> <tr> <td>Power On Sequence</td> <td>Idle Mode Off</td> </tr> <tr> <td>S/W Reset</td> <td>Idle Mode Off</td> </tr> <tr> <td>H/W Reset</td> <td>Idle Mode Off</td> </tr> </tbody> </table>											Status	Default Value	Power On Sequence	Idle Mode Off	S/W Reset	Idle Mode Off	H/W Reset	Idle Mode Off
Status	Default Value																		
Power On Sequence	Idle Mode Off																		
S/W Reset	Idle Mode Off																		
H/W Reset	Idle Mode Off																		
Flow Chart	<pre> graph TD A([Idle off mode]) --> B[IDMON] B --> C([Idle on mode]) </pre> <p>Legend:</p> <ul style="list-style-type: none"> Command: Rectangle Parameter: Parallelogram Display: Oval Action: Arrow Mode: Rounded Rectangle Sequential transfer: Speech bubble 																		

5.3.25. Interface Pixel Format (3Ah)

Command Page		Page 0																											
Address	Parameter	W/R	D7	D6	D5	D4	D3	D2	D1	D0	Default																		
3Ah	1st	W	0	0	0	0	0	DBI[2:0]			07h																		
Description	<p>3A: COLMOD (Interface Pixel Format).</p> <p>This command is used to define the format of RGB picture data, which is to be transferred via the MIPI DSI Command Mode. The formats are shown in the table:</p> <table border="1" style="margin-left: auto; margin-right: auto;"> <thead> <tr> <th>Interface Format</th> <th>DBI[2:0]</th> </tr> </thead> <tbody> <tr><td>Not Defined</td><td>000</td></tr> <tr><td>Not Defined</td><td>001</td></tr> <tr><td>Not Defined</td><td>010</td></tr> <tr><td>Not Defined</td><td>011</td></tr> <tr><td>Not Defined</td><td>100</td></tr> <tr><td>16 bit/pixel</td><td>101</td></tr> <tr><td>18 bit/pixel</td><td>110</td></tr> <tr><td>24 bit/pixel</td><td>111</td></tr> </tbody> </table>											Interface Format	DBI[2:0]	Not Defined	000	Not Defined	001	Not Defined	010	Not Defined	011	Not Defined	100	16 bit/pixel	101	18 bit/pixel	110	24 bit/pixel	111
	Interface Format	DBI[2:0]																											
Not Defined	000																												
Not Defined	001																												
Not Defined	010																												
Not Defined	011																												
Not Defined	100																												
16 bit/pixel	101																												
18 bit/pixel	110																												
24 bit/pixel	111																												
Restriction	There is no visible effect until the Frame Memory is written to.																												
Register Availability	<table border="1" style="margin-left: auto; margin-right: auto;"> <thead> <tr> <th>Status</th> <th>Availability</th> </tr> </thead> <tbody> <tr> <td>Normal Mode On, Idle Mode Off, Sleep Out</td> <td>Yes</td> </tr> <tr> <td>Normal Mode On, Idle Mode On, Sleep Out</td> <td>Yes</td> </tr> <tr> <td>Sleep In</td> <td>Yes</td> </tr> </tbody> </table>											Status	Availability	Normal Mode On, Idle Mode Off, Sleep Out	Yes	Normal Mode On, Idle Mode On, Sleep Out	Yes	Sleep In	Yes										
Status	Availability																												
Normal Mode On, Idle Mode Off, Sleep Out	Yes																												
Normal Mode On, Idle Mode On, Sleep Out	Yes																												
Sleep In	Yes																												
Default	<table border="1" style="margin-left: auto; margin-right: auto;"> <thead> <tr> <th>Status</th> <th>Default Value</th> </tr> </thead> <tbody> <tr> <td>Power On Sequence</td> <td>07h</td> </tr> <tr> <td>S/W Reset</td> <td>07h</td> </tr> <tr> <td>H/W Reset</td> <td>07h</td> </tr> </tbody> </table>											Status	Default Value	Power On Sequence	07h	S/W Reset	07h	H/W Reset	07h										
Status	Default Value																												
Power On Sequence	07h																												
S/W Reset	07h																												
H/W Reset	07h																												
Flow Chart	<div style="display: flex; align-items: center;"> <div style="flex: 1;"> <pre> graph TD A([16 Bit/Pixel Mode]) --> B[COLMOD] B --> C[/111/] C --> D([24 Bit/Pixel Mode]) </pre> </div> <div style="flex: 1; border: 1px dashed black; padding: 5px;"> <p>Legend</p> <ul style="list-style-type: none"> Command Parameter Display Action Mode Sequential transfer </div> </div>																												

5.3.26. Memory Write Continue (3Ch)

Command Page			Page 0																
Address	Parameter	W/R	D7	D6	D5	D4	D3	D2	D1	D0	Default								
3Ch	1st	W	D1[23:16]								00~FFh								
	2nd	W	D1[15:8]								00~FFh								
	3rd	W	D1[7:0]								00~FFh								
	...	W	...								00~FFh								
	Nth	W	Dn[7:0]								00~FFh								
Description	<p>3Ch: RAMWRC (Memory Write Continue).</p> <p>This command is used to transfer data from the MCU to the Frame Memory, if want to continue the Frame Memory write after the “Memory Write (2Ch)” command. This command makes no change to the status of the other driver. When this command is accepted, the column register and the page register are not reset to zero since it has been done on “Memory Write (2Ch)” command.</p> <p>Sending any other command can stop frame Write.</p>																		
Restriction	<p>This command’s parameter length must be based on 2 pixel data length (6 bytes) (N=3 x n, N is multiple of 6).</p> <p>Transmission sequences: LP_00 → HS for R2Ch → LP_00 → HS for R3Ch → LP_00 → HS for CMD → LP_00</p>																		
Register Availability	<table border="1"> <thead> <tr> <th>Status</th> <th>Availability</th> </tr> </thead> <tbody> <tr> <td>Normal Mode On, Idle Mode Off, Sleep Out</td> <td>Yes</td> </tr> <tr> <td>Normal Mode On, Idle Mode On, Sleep Out</td> <td>Yes</td> </tr> <tr> <td>Sleep In</td> <td>Yes</td> </tr> </tbody> </table>											Status	Availability	Normal Mode On, Idle Mode Off, Sleep Out	Yes	Normal Mode On, Idle Mode On, Sleep Out	Yes	Sleep In	Yes
Status	Availability																		
Normal Mode On, Idle Mode Off, Sleep Out	Yes																		
Normal Mode On, Idle Mode On, Sleep Out	Yes																		
Sleep In	Yes																		
Default	<table border="1"> <thead> <tr> <th>Status</th> <th>Default Value</th> </tr> </thead> <tbody> <tr> <td>Power On Sequence</td> <td>Contents of memory is set randomly</td> </tr> <tr> <td>S/W Reset</td> <td>Contents of memory is set randomly</td> </tr> <tr> <td>H/W Reset</td> <td>Contents of memory is set randomly</td> </tr> </tbody> </table>											Status	Default Value	Power On Sequence	Contents of memory is set randomly	S/W Reset	Contents of memory is set randomly	H/W Reset	Contents of memory is set randomly
Status	Default Value																		
Power On Sequence	Contents of memory is set randomly																		
S/W Reset	Contents of memory is set randomly																		
H/W Reset	Contents of memory is set randomly																		
Flow Chart	<pre> graph TD A[RAMWRC] --> B(Image Data D1[23:0], D2[23:0], ..., Dn[23:0]) B --> C[Any Command] </pre> <p>Legend</p> <ul style="list-style-type: none"> Command: Rectangle Parameter: Parallelogram Display: Trapezoid Action: Arrow Mode: Rounded Rectangle Sequential transfer: Oval with tail 																		

5.3.27. Set_Tear_Scanline (44h)

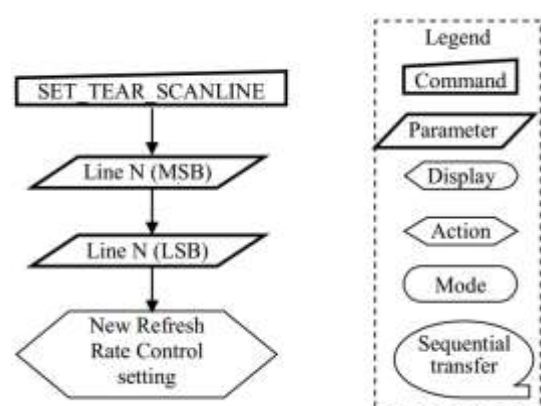
Command Page			Page 0																
Address	Parameter	W/R	D7	D6	D5	D4	D3	D2	D1	D0	Default								
44h	1st	W	0	0	0	0	0	TE_LINE[10:8]			00h								
	2nd	W	TE_LINE[7:0]									00h							
Description	<p>44h: SET_TEAR_SCANLINE.</p> <p>This command turns on the display module's Tearing Effect output signal on the TE signal line when the display module reaches line N.</p> <p>The Tearing Effect Line On has one parameter that describes the Tearing Effect Output Line mode. After issuing a set_tear_scanline command to the display module, the Tearing Effect output signal, e.g. as in DBI-2 systems, shall be a delayed version of V-Blanking information as illustrated by below figure.</p> <p>In other words, the TE pulse width needs to be identical with normal mode Vsync related TE pulse.</p>																		
	 <p>Note that set_tear_scanline with N = 0 is equivalent to set_tear_on with M = 0.</p> <p>The Tearing Effect Output line shall be active low when the display module is in Sleep mode.</p>																		
Restriction	<p>This command takes affect on the frame following the current frame.</p> <p>Therefore, if the Tear Effect (TE) output is already ON, the TE output shall continue to operate as programmed by the previous set_tear_on, or set_tear_scanline, command until the end of the frame.</p>																		
Register Availability	<table border="1"> <thead> <tr> <th>Status</th> <th>Availability</th> </tr> </thead> <tbody> <tr> <td>Normal Mode On, Idle Mode Off, Sleep Out</td> <td>Yes</td> </tr> <tr> <td>Normal Mode On, Idle Mode On, Sleep Out</td> <td>Yes</td> </tr> <tr> <td>Sleep In</td> <td>No</td> </tr> </tbody> </table>											Status	Availability	Normal Mode On, Idle Mode Off, Sleep Out	Yes	Normal Mode On, Idle Mode On, Sleep Out	Yes	Sleep In	No
Status	Availability																		
Normal Mode On, Idle Mode Off, Sleep Out	Yes																		
Normal Mode On, Idle Mode On, Sleep Out	Yes																		
Sleep In	No																		
Default	<table border="1"> <thead> <tr> <th>Status</th> <th>Default Value</th> </tr> </thead> <tbody> <tr> <td>Power On Sequence</td> <td>N=0</td> </tr> <tr> <td>S/W Reset</td> <td>N=0</td> </tr> <tr> <td>H/W Reset</td> <td>N=0</td> </tr> </tbody> </table>											Status	Default Value	Power On Sequence	N=0	S/W Reset	N=0	H/W Reset	N=0
Status	Default Value																		
Power On Sequence	N=0																		
S/W Reset	N=0																		
H/W Reset	N=0																		
Flow Chart																			

5.3.28. Get_Tear_Scanline (45h)

Command Page			Page 0																
Address	Parameter	W/R	D7	D6	D5	D4	D3	D2	D1	D0	Default								
45h	1st	R	0	0	0	0	0	TE_LINE[10:8]			00h								
	2nd	R	TE_LINE[7:0]									00h							
Description		45h: GET_TEAR_SCANLINE. This command returns setting value of Set_Tear_Scanline command (44h).																	
Restriction		None																	
Register Availability		<table border="1"> <thead> <tr> <th>Status</th> <th>Availability</th> </tr> </thead> <tbody> <tr> <td>Normal Mode On, Idle Mode Off, Sleep Out</td> <td>Yes</td> </tr> <tr> <td>Normal Mode On, Idle Mode On, Sleep Out</td> <td>Yes</td> </tr> <tr> <td>Sleep In</td> <td>No</td> </tr> </tbody> </table>										Status	Availability	Normal Mode On, Idle Mode Off, Sleep Out	Yes	Normal Mode On, Idle Mode On, Sleep Out	Yes	Sleep In	No
Status	Availability																		
Normal Mode On, Idle Mode Off, Sleep Out	Yes																		
Normal Mode On, Idle Mode On, Sleep Out	Yes																		
Sleep In	No																		
Default		<table border="1"> <thead> <tr> <th>Status</th> <th>Default Value</th> </tr> </thead> <tbody> <tr> <td>Power On Sequence</td> <td>N=0</td> </tr> <tr> <td>S/W Reset</td> <td>N=0</td> </tr> <tr> <td>H/W Reset</td> <td>N=0</td> </tr> </tbody> </table>										Status	Default Value	Power On Sequence	N=0	S/W Reset	N=0	H/W Reset	N=0
Status	Default Value																		
Power On Sequence	N=0																		
S/W Reset	N=0																		
H/W Reset	N=0																		
Flow Chart		<pre> graph TD A[Read GET_TEAR_SCANLINE] --> B[/Send 1st Parameter/] B --> C[/Send 2nd Parameter/] </pre> <p>Host Display</p> <p>Legend: Command: Rectangle Parameter: Parallelogram Display: Oval Action: Diamond Mode: Circle Sequential transfer: Cloud</p>																	

5.3.29. Write Display Brightness Value (51h)

Command Page			Page 0																
Address	Parameter	W/R	D7	D6	D5	D4	D3	D2	D1	D0	Default								
51h	1st	W	0	0	0	0	DBV[11:8]				00h								
	2nd	W	DBV[7:0]									00h							
Description		<p>51h: WRDISBV (Write Display Brightness).</p> <p>This command is used to adjust the brightness value of the display.</p> <p>DBV[11:0]: 12 bit, for display brightness of manual brightness setting and the CABC in the ILI9881C-0D. PWM output signal and LEDPWM pin will control the LED driver IC in order to control the display brightness. In principle relationship is that 0000h value means the lowest brightness and 0FFFh value means the highest brightness.</p>																	
Restriction		None																	
Register Availability		<table border="1"> <thead> <tr> <th>Status</th> <th>Availability</th> </tr> </thead> <tbody> <tr> <td>Normal Mode On, Idle Mode Off, Sleep Out</td> <td>Yes</td> </tr> <tr> <td>Normal Mode On, Idle Mode On, Sleep Out</td> <td>Yes</td> </tr> <tr> <td>Sleep In</td> <td>Yes</td> </tr> </tbody> </table>										Status	Availability	Normal Mode On, Idle Mode Off, Sleep Out	Yes	Normal Mode On, Idle Mode On, Sleep Out	Yes	Sleep In	Yes
Status	Availability																		
Normal Mode On, Idle Mode Off, Sleep Out	Yes																		
Normal Mode On, Idle Mode On, Sleep Out	Yes																		
Sleep In	Yes																		
Default		<table border="1"> <thead> <tr> <th>Status</th> <th>Default Value</th> </tr> </thead> <tbody> <tr> <td>Power On Sequence</td> <td>00h_00h</td> </tr> <tr> <td>S/W Reset</td> <td>00h_00h</td> </tr> <tr> <td>H/W Reset</td> <td>00h_00h</td> </tr> </tbody> </table>										Status	Default Value	Power On Sequence	00h_00h	S/W Reset	00h_00h	H/W Reset	00h_00h
Status	Default Value																		
Power On Sequence	00h_00h																		
S/W Reset	00h_00h																		
H/W Reset	00h_00h																		
Flow Chart		<pre> graph TD A[WRDISBV] --> B[/DBV (MSB)/] B --> C[/DBV (LSB)/] C --> D{{New Display Brightness Value Loaded}} </pre>																	

5.3.30. Read Display Brightness Value (52h)

Command Page			Page 0																
Address	Parameter	W/R	D7	D6	D5	D4	D3	D2	D1	D0	Default								
52h	1st	R	0	0	0	0	DBV[11:8]				00h								
	2nd	R	DBV[7:0]								00h								
Description	<p>52h: RDDISBV (Read Display Brightness Value).</p> <p>This command returns the brightness value of the display. It should be checked what the relationship between this returned value and output brightness of the display. This relationship is defined on the display module specification.</p> <p>In principle the relationship is that 0000h value means the lowest brightness and 0FFFh value means the highest brightness.</p> <p>DBV[11:0] is reset when display is in sleep-in mode.</p> <p>DBV[11:0] is '0' when bit BCTRL of "5.3.31Write CTRL Display Value (53h)" command is '0'.</p> <p>DBV[11:0] is manual set brightness specified with "5.3.31Write CTRL Display Value (53h)" command when bit BCTRL is '1'.</p>																		
Restriction	None																		
Register Availability	<table border="1"> <thead> <tr> <th>Status</th> <th>Availability</th> </tr> </thead> <tbody> <tr> <td>Normal Mode On, Idle Mode Off, Sleep Out</td> <td>Yes</td> </tr> <tr> <td>Normal Mode On, Idle Mode On, Sleep Out</td> <td>Yes</td> </tr> <tr> <td>Sleep In</td> <td>Yes</td> </tr> </tbody> </table>											Status	Availability	Normal Mode On, Idle Mode Off, Sleep Out	Yes	Normal Mode On, Idle Mode On, Sleep Out	Yes	Sleep In	Yes
Status	Availability																		
Normal Mode On, Idle Mode Off, Sleep Out	Yes																		
Normal Mode On, Idle Mode On, Sleep Out	Yes																		
Sleep In	Yes																		
Default	<table border="1"> <thead> <tr> <th>Status</th> <th>Default Value</th> </tr> </thead> <tbody> <tr> <td>Power On Sequence</td> <td>00h_00h</td> </tr> <tr> <td>S/W Reset</td> <td>00h_00h</td> </tr> <tr> <td>H/W Reset</td> <td>00h_00h</td> </tr> </tbody> </table>											Status	Default Value	Power On Sequence	00h_00h	S/W Reset	00h_00h	H/W Reset	00h_00h
Status	Default Value																		
Power On Sequence	00h_00h																		
S/W Reset	00h_00h																		
H/W Reset	00h_00h																		
Flow Chart																			

5.3.31. Write CTRL Display Value (53h)

Command Page		Page 0																											
Address	Parameter	W/R	D7	D6	D5	D4	D3	D2	D1	D0	Default																		
53h	1st	W	0	0	BCTRL	0	DD	BL	0	0	00h																		
Description	<p>53h: WRCTRLD (Write Control Display).</p> <p>This command is used to control the display brightness.</p> <p>BCTRL: Brightness Control Block On/Off. This bit is always used to switch brightness for display.</p> <table border="1"> <thead> <tr> <th>BCTRL</th> <th>Description</th> </tr> </thead> <tbody> <tr> <td>0</td> <td>Brightness Control Block Off (DBV[11:0] = 0000h)</td> </tr> <tr> <td>1</td> <td>Brightness Control Block On (DBV[11:0] is active)</td> </tr> </tbody> </table> <p>DD: Display Dimming Control.</p> <table border="1"> <thead> <tr> <th>DD</th> <th>Description</th> </tr> </thead> <tbody> <tr> <td>0</td> <td>Display Dimming Off</td> </tr> <tr> <td>1</td> <td>Display Dimming On</td> </tr> </tbody> </table> <p>BL: Backlight Control On/Off</p> <table border="1"> <thead> <tr> <th>BL</th> <th>Description</th> </tr> </thead> <tbody> <tr> <td>0</td> <td>Backlight Control Off</td> </tr> <tr> <td>1</td> <td>Backlight Control On</td> </tr> </tbody> </table> <p>Dimming function is adapted to the brightness registers for display when the bit BCTRL is changed at DD = 1, e.g. BCTRL: 0-> 1 or 1-> 0.</p> <p>When the BL bit changes from 'ON' to 'OFF', backlight is turned off without gradual dimming, even if Display Dimming On (DD = 1) are selected.</p>											BCTRL	Description	0	Brightness Control Block Off (DBV[11:0] = 0000h)	1	Brightness Control Block On (DBV[11:0] is active)	DD	Description	0	Display Dimming Off	1	Display Dimming On	BL	Description	0	Backlight Control Off	1	Backlight Control On
	BCTRL	Description																											
	0	Brightness Control Block Off (DBV[11:0] = 0000h)																											
	1	Brightness Control Block On (DBV[11:0] is active)																											
DD	Description																												
0	Display Dimming Off																												
1	Display Dimming On																												
BL	Description																												
0	Backlight Control Off																												
1	Backlight Control On																												
Restriction	None																												
Register Availability	<table border="1"> <thead> <tr> <th>Status</th> <th>Availability</th> </tr> </thead> <tbody> <tr> <td>Normal Mode On, Idle Mode Off, Sleep Out</td> <td>Yes</td> </tr> <tr> <td>Normal Mode On, Idle Mode On, Sleep Out</td> <td>Yes</td> </tr> <tr> <td>Sleep In</td> <td>Yes</td> </tr> </tbody> </table>											Status	Availability	Normal Mode On, Idle Mode Off, Sleep Out	Yes	Normal Mode On, Idle Mode On, Sleep Out	Yes	Sleep In	Yes										
Status	Availability																												
Normal Mode On, Idle Mode Off, Sleep Out	Yes																												
Normal Mode On, Idle Mode On, Sleep Out	Yes																												
Sleep In	Yes																												
Default	<table border="1"> <thead> <tr> <th>Status</th> <th>Default Value</th> </tr> </thead> <tbody> <tr> <td>Power On Sequence</td> <td>00h</td> </tr> <tr> <td>S/W Reset</td> <td>00h</td> </tr> <tr> <td>H/W Reset</td> <td>00h</td> </tr> </tbody> </table>											Status	Default Value	Power On Sequence	00h	S/W Reset	00h	H/W Reset	00h										
Status	Default Value																												
Power On Sequence	00h																												
S/W Reset	00h																												
H/W Reset	00h																												
Flow Chart	<pre> graph TD A[WRCTRLD] --> B[/HBM, BCTRL, DD, BL/] B --> C[/New Control Value Loaded/] </pre> <p>Legend:</p> <ul style="list-style-type: none"> Command: Rectangle Parameter: Parallelogram Display: Oval Action: Hexagon Mode: Circle Sequential transfer: Dashed line 																												

5.3.32. Read CTRL Display Value (54h)

Command Page		Page 0																											
Address	Parameter	W/R	D7	D6	D5	D4	D3	D2	D1	D0	Default																		
54h	1st	R	0	0	BCTRL	0	DD	BL	0	0	00h																		
Description	<p>54h: RDCTRLD (Read Control Value Display).</p> <p>This command returns the display brightness control values.</p> <p>BCTRL: Brightness Control Block On/Off. This bit is always used to switch brightness for display.</p> <table border="1"> <thead> <tr> <th>BCTRL</th> <th>Description</th> </tr> </thead> <tbody> <tr> <td>0</td> <td>Brightness Control Block Off (DBV[11:0] = 0000h)</td> </tr> <tr> <td>1</td> <td>Brightness Control Block On (DBV[11:0] is active)</td> </tr> </tbody> </table> <p>DD: Display Dimming Control.</p> <table border="1"> <thead> <tr> <th>DD</th> <th>Description</th> </tr> </thead> <tbody> <tr> <td>0</td> <td>Display Dimming Off</td> </tr> <tr> <td>1</td> <td>Display Dimming On</td> </tr> </tbody> </table> <p>BL: Backlight Control On/Off</p> <table border="1"> <thead> <tr> <th>BL</th> <th>Description</th> </tr> </thead> <tbody> <tr> <td>0</td> <td>Backlight Control Off</td> </tr> <tr> <td>1</td> <td>Backlight Control On</td> </tr> </tbody> </table> <p>Dimming function is adapted to the brightness registers for display when the bit BCTRL is changed at DD = 1, e.g. BCTRL: 0-> 1 or 1-> 0.</p> <p>When the BL bit changes from 'ON' to 'OFF', backlight is turned off without gradual dimming, even if Display Dimming On (DD = 1) are selected.</p>											BCTRL	Description	0	Brightness Control Block Off (DBV[11:0] = 0000h)	1	Brightness Control Block On (DBV[11:0] is active)	DD	Description	0	Display Dimming Off	1	Display Dimming On	BL	Description	0	Backlight Control Off	1	Backlight Control On
	BCTRL	Description																											
	0	Brightness Control Block Off (DBV[11:0] = 0000h)																											
	1	Brightness Control Block On (DBV[11:0] is active)																											
DD	Description																												
0	Display Dimming Off																												
1	Display Dimming On																												
BL	Description																												
0	Backlight Control Off																												
1	Backlight Control On																												
Restriction	None																												
Register Availability	<table border="1"> <thead> <tr> <th>Status</th> <th>Availability</th> </tr> </thead> <tbody> <tr> <td>Normal Mode On, Idle Mode Off, Sleep Out</td> <td>Yes</td> </tr> <tr> <td>Normal Mode On, Idle Mode On, Sleep Out</td> <td>Yes</td> </tr> <tr> <td>Sleep In</td> <td>Yes</td> </tr> </tbody> </table>											Status	Availability	Normal Mode On, Idle Mode Off, Sleep Out	Yes	Normal Mode On, Idle Mode On, Sleep Out	Yes	Sleep In	Yes										
Status	Availability																												
Normal Mode On, Idle Mode Off, Sleep Out	Yes																												
Normal Mode On, Idle Mode On, Sleep Out	Yes																												
Sleep In	Yes																												
Default	<table border="1"> <thead> <tr> <th>Status</th> <th>Default Value</th> </tr> </thead> <tbody> <tr> <td>Power On Sequence</td> <td>00h</td> </tr> <tr> <td>S/W Reset</td> <td>00h</td> </tr> <tr> <td>H/W Reset</td> <td>00h</td> </tr> </tbody> </table>											Status	Default Value	Power On Sequence	00h	S/W Reset	00h	H/W Reset	00h										
Status	Default Value																												
Power On Sequence	00h																												
S/W Reset	00h																												
H/W Reset	00h																												
Flow Chart																													

5.3.33. Write Power Save (55h)

Command Page			Page 0																																												
Address	Parameter	W/R	D7	D6	D5	D4	D3	D2	D1	D0	Default																																				
55h	1st	W	PWRSAVE[7:0]									00h																																			
Description	55h: PWRSAVE (Write Power Save). This command is used to write the settings for power save control functionalities.																																														
	<table border="1"> <thead> <tr> <th>PWRSAVE[7:0]</th> <th>Function</th> <th>Note</th> </tr> </thead> <tbody> <tr> <td>00000000</td> <td>Power Save Off</td> <td>-</td> </tr> <tr> <td>00000001</td> <td>Power Save Low</td> <td>Conservative Setting of CABC/DBLC</td> </tr> <tr> <td>00000010</td> <td>Power Save Medium</td> <td>Medium Setting of CABC/DBLC</td> </tr> <tr> <td>00000011</td> <td>Power Save High</td> <td>Aggressive Setting of CABC/DBLC</td> </tr> <tr> <td>1000XXXX</td> <td>IE On – Low</td> <td>Low Enhancement of LCD</td> </tr> <tr> <td>1001XXXX</td> <td>IE On – Medium</td> <td>Medium Enhancement of LCD</td> </tr> <tr> <td>1011XXXX</td> <td>IE On – High</td> <td>High Enhancement of LCD</td> </tr> <tr> <td>0100XXXX</td> <td>SRE - Low</td> <td>Sunlight readability enhancement</td> </tr> <tr> <td>0101XXXX</td> <td>SRE - Medium</td> <td>Sunlight readability enhancement</td> </tr> <tr> <td>0110XXXX</td> <td>SRE - High</td> <td>Sunlight readability enhancement</td> </tr> <tr> <td>Others</td> <td>Reserved</td> <td>-</td> </tr> </tbody> </table>											PWRSAVE[7:0]	Function	Note	00000000	Power Save Off	-	00000001	Power Save Low	Conservative Setting of CABC/DBLC	00000010	Power Save Medium	Medium Setting of CABC/DBLC	00000011	Power Save High	Aggressive Setting of CABC/DBLC	1000XXXX	IE On – Low	Low Enhancement of LCD	1001XXXX	IE On – Medium	Medium Enhancement of LCD	1011XXXX	IE On – High	High Enhancement of LCD	0100XXXX	SRE - Low	Sunlight readability enhancement	0101XXXX	SRE - Medium	Sunlight readability enhancement	0110XXXX	SRE - High	Sunlight readability enhancement	Others	Reserved	-
	PWRSAVE[7:0]	Function	Note																																												
	00000000	Power Save Off	-																																												
	00000001	Power Save Low	Conservative Setting of CABC/DBLC																																												
	00000010	Power Save Medium	Medium Setting of CABC/DBLC																																												
	00000011	Power Save High	Aggressive Setting of CABC/DBLC																																												
	1000XXXX	IE On – Low	Low Enhancement of LCD																																												
	1001XXXX	IE On – Medium	Medium Enhancement of LCD																																												
	1011XXXX	IE On – High	High Enhancement of LCD																																												
	0100XXXX	SRE - Low	Sunlight readability enhancement																																												
	0101XXXX	SRE - Medium	Sunlight readability enhancement																																												
0110XXXX	SRE - High	Sunlight readability enhancement																																													
Others	Reserved	-																																													
CABC = Content Adaptive Brightness Control																																															
DBLC = Dynamic Backlight Control																																															
IE = Image Enhancement																																															
Restriction	None																																														
Register Availability	<table border="1"> <thead> <tr> <th>Status</th> <th>Availability</th> </tr> </thead> <tbody> <tr> <td>Normal Mode On, Idle Mode Off, Sleep Out</td> <td>Yes</td> </tr> <tr> <td>Normal Mode On, Idle Mode On, Sleep Out</td> <td>Yes</td> </tr> <tr> <td>Sleep In</td> <td>Yes</td> </tr> </tbody> </table>											Status	Availability	Normal Mode On, Idle Mode Off, Sleep Out	Yes	Normal Mode On, Idle Mode On, Sleep Out	Yes	Sleep In	Yes																												
Status	Availability																																														
Normal Mode On, Idle Mode Off, Sleep Out	Yes																																														
Normal Mode On, Idle Mode On, Sleep Out	Yes																																														
Sleep In	Yes																																														
Default	<table border="1"> <thead> <tr> <th>Status</th> <th>Default Value</th> </tr> </thead> <tbody> <tr> <td>Power On Sequence</td> <td>00h</td> </tr> <tr> <td>S/W Reset</td> <td>00h</td> </tr> <tr> <td>H/W Reset</td> <td>00h</td> </tr> </tbody> </table>											Status	Default Value	Power On Sequence	00h	S/W Reset	00h	H/W Reset	00h																												
Status	Default Value																																														
Power On Sequence	00h																																														
S/W Reset	00h																																														
H/W Reset	00h																																														
Flow Chart	<pre> graph TD WRPWRSAVE[WRPWRSAVE] --> Parameter[/Parameter/] Parameter --> NewPowerSaveMode{{New Power Save Mode}} </pre>																																														

5.3.34. Read Power Save (56h)

Command Page			Page 0																																												
Address	Parameter	W/R	D7	D6	D5	D4	D3	D2	D1	D0	Default																																				
56h	1st	R	PWRSAVE[7:0]									00h																																			
Description	56h: RDPWRSAVE (Read Power Save). This command is used to read the settings for power save control functionalities.																																														
	<table border="1"> <thead> <tr> <th>PWRSAVE[7:0]</th> <th>Function</th> <th>Note</th> </tr> </thead> <tbody> <tr> <td>00000000</td> <td>Power Save Off</td> <td>-</td> </tr> <tr> <td>00000001</td> <td>Power Save Low</td> <td>Conservative Setting of CABC/DBLC</td> </tr> <tr> <td>00000010</td> <td>Power Save Medium</td> <td>Medium Setting of CABC/DBLC</td> </tr> <tr> <td>00000011</td> <td>Power Save High</td> <td>Aggressive Setting of CABC/DBLC</td> </tr> <tr> <td>1000XXXX</td> <td>IE On – Low</td> <td>Low Enhancement of LCD</td> </tr> <tr> <td>1001XXXX</td> <td>IE On – Medium</td> <td>Medium Enhancement of LCD</td> </tr> <tr> <td>1011XXXX</td> <td>IE On – High</td> <td>High Enhancement of LCD</td> </tr> <tr> <td>0100XXXX</td> <td>SRE - Low</td> <td>Sunlight readability enhancement</td> </tr> <tr> <td>0101XXXX</td> <td>SRE - Medium</td> <td>Sunlight readability enhancement</td> </tr> <tr> <td>0110XXXX</td> <td>SRE - High</td> <td>Sunlight readability enhancement</td> </tr> <tr> <td>Others</td> <td>Reserved</td> <td>-</td> </tr> </tbody> </table>											PWRSAVE[7:0]	Function	Note	00000000	Power Save Off	-	00000001	Power Save Low	Conservative Setting of CABC/DBLC	00000010	Power Save Medium	Medium Setting of CABC/DBLC	00000011	Power Save High	Aggressive Setting of CABC/DBLC	1000XXXX	IE On – Low	Low Enhancement of LCD	1001XXXX	IE On – Medium	Medium Enhancement of LCD	1011XXXX	IE On – High	High Enhancement of LCD	0100XXXX	SRE - Low	Sunlight readability enhancement	0101XXXX	SRE - Medium	Sunlight readability enhancement	0110XXXX	SRE - High	Sunlight readability enhancement	Others	Reserved	-
	PWRSAVE[7:0]	Function	Note																																												
	00000000	Power Save Off	-																																												
	00000001	Power Save Low	Conservative Setting of CABC/DBLC																																												
	00000010	Power Save Medium	Medium Setting of CABC/DBLC																																												
	00000011	Power Save High	Aggressive Setting of CABC/DBLC																																												
	1000XXXX	IE On – Low	Low Enhancement of LCD																																												
	1001XXXX	IE On – Medium	Medium Enhancement of LCD																																												
	1011XXXX	IE On – High	High Enhancement of LCD																																												
0100XXXX	SRE - Low	Sunlight readability enhancement																																													
0101XXXX	SRE - Medium	Sunlight readability enhancement																																													
0110XXXX	SRE - High	Sunlight readability enhancement																																													
Others	Reserved	-																																													
CABC = Content Adaptive Brightness Control																																															
DBLC = Dynamic Backlight Control																																															
IE = Image Enhancement																																															
Restriction	None																																														
Register Availability	<table border="1"> <thead> <tr> <th>Status</th> <th>Availability</th> </tr> </thead> <tbody> <tr> <td>Normal Mode On, Idle Mode Off, Sleep Out</td> <td>Yes</td> </tr> <tr> <td>Normal Mode On, Idle Mode On, Sleep Out</td> <td>Yes</td> </tr> <tr> <td>Sleep In</td> <td>Yes</td> </tr> </tbody> </table>											Status	Availability	Normal Mode On, Idle Mode Off, Sleep Out	Yes	Normal Mode On, Idle Mode On, Sleep Out	Yes	Sleep In	Yes																												
Status	Availability																																														
Normal Mode On, Idle Mode Off, Sleep Out	Yes																																														
Normal Mode On, Idle Mode On, Sleep Out	Yes																																														
Sleep In	Yes																																														
Default	<table border="1"> <thead> <tr> <th>Status</th> <th>Default Value</th> </tr> </thead> <tbody> <tr> <td>Power On Sequence</td> <td>00h</td> </tr> <tr> <td>S/W Reset</td> <td>00h</td> </tr> <tr> <td>H/W Reset</td> <td>00h</td> </tr> </tbody> </table>											Status	Default Value	Power On Sequence	00h	S/W Reset	00h	H/W Reset	00h																												
Status	Default Value																																														
Power On Sequence	00h																																														
S/W Reset	00h																																														
H/W Reset	00h																																														
Flow Chart	<pre> graph TD A[Read RDPWRSAVE] --> B[/Send Parameter/] B --> C[Host/Display] </pre> <p>Legend:</p> <ul style="list-style-type: none"> Command: Rectangle Parameter: Parallelogram Display: Oval Action: Arrow Mode: Oval Sequential transfer: Circle with tail 																																														

5.3.35. Stop Transition (59h)

Command Page			Page 0																
Address	Parameter	W/R	D7	D6	D5	D4	D3	D2	D1	D0	Default								
59h	-	W	No Argument									-							
Description	<p>59h: STOP_TR (Stop Transition).</p> <p>When DD bit status of "5.3.31Write CTRL Display Value (53h)" register is '1', applying this command instantly stops the ongoing transition of Display Dimming.</p> <p>When display module receives this command, the current output value stays active.</p>																		
Restriction	This command has no effect when Display Dimming transition is not active.																		
Register Availability	<table border="1"> <thead> <tr> <th>Status</th> <th>Availability</th> </tr> </thead> <tbody> <tr> <td>Normal Mode On, Idle Mode Off, Sleep Out</td> <td>Yes</td> </tr> <tr> <td>Normal Mode On, Idle Mode On, Sleep Out</td> <td>Yes</td> </tr> <tr> <td>Sleep In</td> <td>Yes</td> </tr> </tbody> </table>											Status	Availability	Normal Mode On, Idle Mode Off, Sleep Out	Yes	Normal Mode On, Idle Mode On, Sleep Out	Yes	Sleep In	Yes
Status	Availability																		
Normal Mode On, Idle Mode Off, Sleep Out	Yes																		
Normal Mode On, Idle Mode On, Sleep Out	Yes																		
Sleep In	Yes																		
Default	<table border="1"> <thead> <tr> <th>Status</th> <th>Default Value</th> </tr> </thead> <tbody> <tr> <td>Power On Sequence</td> <td>Off</td> </tr> <tr> <td>S/W Reset</td> <td>Off</td> </tr> <tr> <td>H/W Reset</td> <td>Off</td> </tr> </tbody> </table>											Status	Default Value	Power On Sequence	Off	S/W Reset	Off	H/W Reset	Off
Status	Default Value																		
Power On Sequence	Off																		
S/W Reset	Off																		
H/W Reset	Off																		
Flow Chart	<pre> graph TD A{{Display Dimming transition is active}} --> B[STOP TR] B --> C{{Stop ongoing transition}} </pre> <p>Legend</p> <ul style="list-style-type: none"> Command: [] Parameter: //] Display: {{ }} (hexagon) Action: {{ }} (hexagon) Mode: [] (rounded) Sequential transfer: () (oval with tail) 																		

5.3.36. Write CABC Minimum Brightness (5Eh)

Command Page			Page 0																
Address	Parameter	W/R	D7	D6	D5	D4	D3	D2	D1	D0	Default								
5Eh	1st	W	0	0	0	0	CMB[11:8]				00h								
	2nd	W	CMB[7:0]								00h								
Description		<p>5Eh: WRCABCMB (Write CABC minimum brightness).</p> <p>This command is used to set the minimum brightness value of the display for CABC function.</p> <p>In principle relationship is that 0000h value means the lowest brightness for CABC and 0FFFh value means the highest brightness for CABC.</p>																	
Restriction		None																	
Register Availability		<table border="1"> <thead> <tr> <th>Status</th> <th>Availability</th> </tr> </thead> <tbody> <tr> <td>Normal Mode On, Idle Mode Off, Sleep Out</td> <td>Yes</td> </tr> <tr> <td>Normal Mode On, Idle Mode On, Sleep Out</td> <td>Yes</td> </tr> <tr> <td>Sleep In</td> <td>Yes</td> </tr> </tbody> </table>										Status	Availability	Normal Mode On, Idle Mode Off, Sleep Out	Yes	Normal Mode On, Idle Mode On, Sleep Out	Yes	Sleep In	Yes
Status	Availability																		
Normal Mode On, Idle Mode Off, Sleep Out	Yes																		
Normal Mode On, Idle Mode On, Sleep Out	Yes																		
Sleep In	Yes																		
Default		<table border="1"> <thead> <tr> <th>Status</th> <th>Default Value</th> </tr> </thead> <tbody> <tr> <td>Power On Sequence</td> <td>00h_00h</td> </tr> <tr> <td>S/W Reset</td> <td>00h_00h</td> </tr> <tr> <td>H/W Reset</td> <td>00h_00h</td> </tr> </tbody> </table>										Status	Default Value	Power On Sequence	00h_00h	S/W Reset	00h_00h	H/W Reset	00h_00h
Status	Default Value																		
Power On Sequence	00h_00h																		
S/W Reset	00h_00h																		
H/W Reset	00h_00h																		
Flow Chart		<pre> graph TD WRCABCMB[WRCABCMB] --> CMB[CMB[7..0]] CMB --> Action[New Display Luminance Value Loaded] </pre>																	

5.3.37. Read CABC Minimum Brightness (5Fh)

Command Page			Page 0																
Address	Parameter	W/R	D7	D6	D5	D4	D3	D2	D1	D0	Default								
5Fh	1st	R	0	0	0	0	CMB[11:8]				00h								
	2nd	R	CMB[7:0]								00h								
Description		<p>5Fh: RDCABCMB (Read CABC Minimum Brightness).</p> <p>This command returns the minimum brightness value of CABC function.</p> <p>In principle the relationship is that 0000h value means the lowest brightness and 0FFFh value means the highest brightness.</p> <p>CMB[11:0] is CABC minimum brightness specified by the Write CABC minimum brightness (5Eh) command.</p>																	
Restriction		None																	
Register Availability		<table border="1"> <thead> <tr> <th>Status</th> <th>Availability</th> </tr> </thead> <tbody> <tr> <td>Normal Mode On, Idle Mode Off, Sleep Out</td> <td>Yes</td> </tr> <tr> <td>Normal Mode On, Idle Mode On, Sleep Out</td> <td>Yes</td> </tr> <tr> <td>Sleep In</td> <td>Yes</td> </tr> </tbody> </table>										Status	Availability	Normal Mode On, Idle Mode Off, Sleep Out	Yes	Normal Mode On, Idle Mode On, Sleep Out	Yes	Sleep In	Yes
Status	Availability																		
Normal Mode On, Idle Mode Off, Sleep Out	Yes																		
Normal Mode On, Idle Mode On, Sleep Out	Yes																		
Sleep In	Yes																		
Default		<table border="1"> <thead> <tr> <th>Status</th> <th>Default Value</th> </tr> </thead> <tbody> <tr> <td>Power On Sequence</td> <td>00h_00h</td> </tr> <tr> <td>S/W Reset</td> <td>00h_00h</td> </tr> <tr> <td>H/W Reset</td> <td>00h_00h</td> </tr> </tbody> </table>										Status	Default Value	Power On Sequence	00h_00h	S/W Reset	00h_00h	H/W Reset	00h_00h
Status	Default Value																		
Power On Sequence	00h_00h																		
S/W Reset	00h_00h																		
H/W Reset	00h_00h																		
Flow Chart		<pre> graph TD A[Read RDCABCMB] --> B[/Send Parameter/] B --> C[Host Display] </pre>																	

5.3.38. Set Transition Time (68h)

Command Page			Page 0																																																																		
Address	Parameter	W/R	D7	D6	D5	D4	D3	D2	D1	D0	Default																																																										
68h	1st	W	TT_STP[7:0]								00h																																																										
	2nd	W	ST_TIM[7:0]								00h																																																										
Description	<p>68h: SET_TT (Set Transition Time).</p> <p>This command controls the total transition time of Display Dimming function.</p> <p>Transition time is adjusted with two parameters, defining as follows:</p> <p>1st Parameter TT_STP [7:0] defines the number of dimming steps for transition.</p> <table border="1"> <thead> <tr> <th>TT_STP [7:0]</th> <th>Description</th> </tr> </thead> <tbody> <tr><td>00h</td><td>1 step</td></tr> <tr><td>01h</td><td>2 step</td></tr> <tr><td>02h</td><td>4 step</td></tr> <tr><td>03h</td><td>8 step</td></tr> <tr><td>04h</td><td>16 step</td></tr> <tr><td>05h</td><td>32 step</td></tr> <tr><td>06h</td><td>64 step</td></tr> <tr><td>07h</td><td>128 step</td></tr> <tr><td>08h</td><td>256 step</td></tr> <tr><td>09h</td><td>512 step</td></tr> <tr><td>0Ah</td><td>1024 step</td></tr> <tr><td>0Bh</td><td>2048 step</td></tr> <tr><td>0Ch</td><td>4096 step</td></tr> <tr><td>Others</td><td>Reserved</td></tr> </tbody> </table> <p>2nd Parameter ST_TIM [7:0] defines the step time as frame units for each dimming step.</p> <table border="1"> <thead> <tr> <th>ST_TIM [7:0]</th> <th>Description</th> </tr> </thead> <tbody> <tr><td>00h</td><td>1 frame</td></tr> <tr><td>01h</td><td>1 frame</td></tr> <tr><td>02h</td><td>2 frame</td></tr> <tr><td>03h</td><td>3 frame</td></tr> <tr><td>04h</td><td>4 frame</td></tr> <tr><td>05h</td><td>5 frame</td></tr> <tr><td>:</td><td>:</td></tr> <tr><td>:</td><td>:</td></tr> <tr><td>FBh</td><td>251 frame</td></tr> <tr><td>FCh</td><td>252 frame</td></tr> <tr><td>FDh</td><td>253 frame</td></tr> <tr><td>FEh</td><td>254 frame</td></tr> <tr><td>FFh</td><td>255 frame</td></tr> </tbody> </table> <p>Thereby, total transition time for dimming can be calculated as follows:</p> <p>TT_STP [7:0] * ST_TIM [7:0] = TT, where TT unit is frame. Value 0000h means the transition is instant</p>											TT_STP [7:0]	Description	00h	1 step	01h	2 step	02h	4 step	03h	8 step	04h	16 step	05h	32 step	06h	64 step	07h	128 step	08h	256 step	09h	512 step	0Ah	1024 step	0Bh	2048 step	0Ch	4096 step	Others	Reserved	ST_TIM [7:0]	Description	00h	1 frame	01h	1 frame	02h	2 frame	03h	3 frame	04h	4 frame	05h	5 frame	:	:	:	:	FBh	251 frame	FCh	252 frame	FDh	253 frame	FEh	254 frame	FFh	255 frame
	TT_STP [7:0]	Description																																																																			
00h	1 step																																																																				
01h	2 step																																																																				
02h	4 step																																																																				
03h	8 step																																																																				
04h	16 step																																																																				
05h	32 step																																																																				
06h	64 step																																																																				
07h	128 step																																																																				
08h	256 step																																																																				
09h	512 step																																																																				
0Ah	1024 step																																																																				
0Bh	2048 step																																																																				
0Ch	4096 step																																																																				
Others	Reserved																																																																				
ST_TIM [7:0]	Description																																																																				
00h	1 frame																																																																				
01h	1 frame																																																																				
02h	2 frame																																																																				
03h	3 frame																																																																				
04h	4 frame																																																																				
05h	5 frame																																																																				
:	:																																																																				
:	:																																																																				
FBh	251 frame																																																																				
FCh	252 frame																																																																				
FDh	253 frame																																																																				
FEh	254 frame																																																																				
FFh	255 frame																																																																				
Restriction	None																																																																				
Register Availability	<table border="1"> <thead> <tr> <th>Status</th> <th>Availability</th> </tr> </thead> <tbody> <tr> <td>Normal Mode On, Idle Mode Off, Sleep Out</td> <td>Yes</td> </tr> <tr> <td>Normal Mode On, Idle Mode On, Sleep Out</td> <td>Yes</td> </tr> <tr> <td>Sleep In</td> <td>Yes</td> </tr> </tbody> </table>											Status	Availability	Normal Mode On, Idle Mode Off, Sleep Out	Yes	Normal Mode On, Idle Mode On, Sleep Out	Yes	Sleep In	Yes																																																		
Status	Availability																																																																				
Normal Mode On, Idle Mode Off, Sleep Out	Yes																																																																				
Normal Mode On, Idle Mode On, Sleep Out	Yes																																																																				
Sleep In	Yes																																																																				

Default	<table border="1"> <thead> <tr> <th>Status</th> <th>Default Value</th> </tr> </thead> <tbody> <tr> <td>Power On Sequence</td> <td>00h_00h</td> </tr> <tr> <td>S/W Reset</td> <td>00h_00h</td> </tr> <tr> <td>H/W Reset</td> <td>00h_00h</td> </tr> </tbody> </table>	Status	Default Value	Power On Sequence	00h_00h	S/W Reset	00h_00h	H/W Reset	00h_00h
Status	Default Value								
Power On Sequence	00h_00h								
S/W Reset	00h_00h								
H/W Reset	00h_00h								
Flow Chart	<pre> graph TD A[SET TT] --> B[/TT_STP/] B --> C[/ST_TIM/] C --> D{{New TT setting loaded}} </pre> <p>Legend</p> <ul style="list-style-type: none"> Command Parameter Display Action Mode Sequential transfer 								

5.3.39. Get Transition Time (69h)

Command Page			Page 0																																																																		
Address	Parameter	W/R	D7	D6	D5	D4	D3	D2	D1	D0	Default																																																										
69h	1st	R	TT_STP[7:0]								00h																																																										
	2nd	R	ST_TIM[7:0]								00h																																																										
Description	<p>69h: GET_TT (Get Transition Time Value).</p> <p>This readout returns the Transition Time value of Display Dimming function, described in section "5.3.38Set Transition Time (68h)".</p> <p>Transition time is adjusted with two parameters, defining as follows:</p> <p>1st Parameter TT_STP [7:0] defines the number of dimming steps for transition.</p> <table border="1"> <thead> <tr> <th>TT_STP [7:0]</th> <th>Description</th> </tr> </thead> <tbody> <tr><td>00h</td><td>1 step</td></tr> <tr><td>01h</td><td>2 step</td></tr> <tr><td>02h</td><td>4 step</td></tr> <tr><td>03h</td><td>8 step</td></tr> <tr><td>04h</td><td>16 step</td></tr> <tr><td>05h</td><td>32 step</td></tr> <tr><td>06h</td><td>64 step</td></tr> <tr><td>07h</td><td>128 step</td></tr> <tr><td>08h</td><td>256 step</td></tr> <tr><td>09h</td><td>512 step</td></tr> <tr><td>0Ah</td><td>1024 step</td></tr> <tr><td>0Bh</td><td>2048 step</td></tr> <tr><td>0Ch</td><td>4096 step</td></tr> <tr><td>Others</td><td>Reserved</td></tr> </tbody> </table> <p>2nd Parameter ST_TIM [7:0] defines the step time as frame units for each dimming step.</p> <table border="1"> <thead> <tr> <th>ST_TIM [7:0]</th> <th>Description</th> </tr> </thead> <tbody> <tr><td>00h</td><td>1 frame</td></tr> <tr><td>01h</td><td>1 frame</td></tr> <tr><td>02h</td><td>2 frame</td></tr> <tr><td>03h</td><td>3 frame</td></tr> <tr><td>04h</td><td>4 frame</td></tr> <tr><td>05h</td><td>5 frame</td></tr> <tr><td>:</td><td>:</td></tr> <tr><td>:</td><td>:</td></tr> <tr><td>FBh</td><td>251 frame</td></tr> <tr><td>FCh</td><td>252 frame</td></tr> <tr><td>FDh</td><td>253 frame</td></tr> <tr><td>FEh</td><td>254 frame</td></tr> <tr><td>FFh</td><td>255 frame</td></tr> </tbody> </table>											TT_STP [7:0]	Description	00h	1 step	01h	2 step	02h	4 step	03h	8 step	04h	16 step	05h	32 step	06h	64 step	07h	128 step	08h	256 step	09h	512 step	0Ah	1024 step	0Bh	2048 step	0Ch	4096 step	Others	Reserved	ST_TIM [7:0]	Description	00h	1 frame	01h	1 frame	02h	2 frame	03h	3 frame	04h	4 frame	05h	5 frame	:	:	:	:	FBh	251 frame	FCh	252 frame	FDh	253 frame	FEh	254 frame	FFh	255 frame
	TT_STP [7:0]	Description																																																																			
00h	1 step																																																																				
01h	2 step																																																																				
02h	4 step																																																																				
03h	8 step																																																																				
04h	16 step																																																																				
05h	32 step																																																																				
06h	64 step																																																																				
07h	128 step																																																																				
08h	256 step																																																																				
09h	512 step																																																																				
0Ah	1024 step																																																																				
0Bh	2048 step																																																																				
0Ch	4096 step																																																																				
Others	Reserved																																																																				
ST_TIM [7:0]	Description																																																																				
00h	1 frame																																																																				
01h	1 frame																																																																				
02h	2 frame																																																																				
03h	3 frame																																																																				
04h	4 frame																																																																				
05h	5 frame																																																																				
:	:																																																																				
:	:																																																																				
FBh	251 frame																																																																				
FCh	252 frame																																																																				
FDh	253 frame																																																																				
FEh	254 frame																																																																				
FFh	255 frame																																																																				
Restriction	None																																																																				
Register Availability	<table border="1"> <thead> <tr> <th>Status</th> <th>Availability</th> </tr> </thead> <tbody> <tr> <td>Normal Mode On, Idle Mode Off, Sleep Out</td> <td>Yes</td> </tr> <tr> <td>Normal Mode On, Idle Mode On, Sleep Out</td> <td>Yes</td> </tr> <tr> <td>Sleep In</td> <td>Yes</td> </tr> </tbody> </table>											Status	Availability	Normal Mode On, Idle Mode Off, Sleep Out	Yes	Normal Mode On, Idle Mode On, Sleep Out	Yes	Sleep In	Yes																																																		
Status	Availability																																																																				
Normal Mode On, Idle Mode Off, Sleep Out	Yes																																																																				
Normal Mode On, Idle Mode On, Sleep Out	Yes																																																																				
Sleep In	Yes																																																																				

<p>Default</p>	<table border="1"> <thead> <tr> <th>Status</th> <th>Default Value</th> </tr> </thead> <tbody> <tr> <td>Power On Sequence</td> <td>00h_00h</td> </tr> <tr> <td>S/W Reset</td> <td>00h_00h</td> </tr> <tr> <td>H/W Reset</td> <td>00h_00h</td> </tr> </tbody> </table>	Status	Default Value	Power On Sequence	00h_00h	S/W Reset	00h_00h	H/W Reset	00h_00h
Status	Default Value								
Power On Sequence	00h_00h								
S/W Reset	00h_00h								
H/W Reset	00h_00h								
<p>Flow Chart</p>	<pre> graph TD A[Read GET_TT] --> B[/Send 1st Parameter/] B --> C[/Send 2nd Parameter/] </pre> <p>Legend</p> <ul style="list-style-type: none"> Command Parameter Display Action Mode Sequential transfer 								

5.3.40. Write Idle Mode Color (80h)

Command Page		Page 0																																													
Address	Parameter	W/R	D7	D6	D5	D4	D3	D2	D1	D0	Default																																				
80h	1st	W	0	0	0	0	0	R	G	B	07h																																				
Description	<p>80h: WRIMCOL.</p> <p>This command can be used to select color for Idle Mode.</p> <p>Color selection is defined in the following table:</p> <table border="1" style="margin-left: auto; margin-right: auto;"> <thead> <tr> <th>Idle Mode Color Selection</th> <th>R</th> <th>G</th> <th>B</th> </tr> </thead> <tbody> <tr> <td>Black</td> <td>0</td> <td>0</td> <td>0</td> </tr> <tr> <td>Blue</td> <td>0</td> <td>0</td> <td>1</td> </tr> <tr> <td>Green</td> <td>0</td> <td>1</td> <td>0</td> </tr> <tr> <td>Cyan</td> <td>0</td> <td>1</td> <td>1</td> </tr> <tr> <td>Red</td> <td>1</td> <td>0</td> <td>0</td> </tr> <tr> <td>Magenta</td> <td>1</td> <td>0</td> <td>1</td> </tr> <tr> <td>Yellow</td> <td>1</td> <td>1</td> <td>0</td> </tr> <tr> <td>White</td> <td>1</td> <td>1</td> <td>1</td> </tr> </tbody> </table> <p>Default setting for color selection for "Normal Black" panel is 'White'; R=G=B:'1'.</p>											Idle Mode Color Selection	R	G	B	Black	0	0	0	Blue	0	0	1	Green	0	1	0	Cyan	0	1	1	Red	1	0	0	Magenta	1	0	1	Yellow	1	1	0	White	1	1	1
	Idle Mode Color Selection	R	G	B																																											
Black	0	0	0																																												
Blue	0	0	1																																												
Green	0	1	0																																												
Cyan	0	1	1																																												
Red	1	0	0																																												
Magenta	1	0	1																																												
Yellow	1	1	0																																												
White	1	1	1																																												
Restriction	None																																														
Register Availability	<table border="1" style="margin-left: auto; margin-right: auto;"> <thead> <tr> <th>Status</th> <th>Availability</th> </tr> </thead> <tbody> <tr> <td>Normal Mode On, Idle Mode Off, Sleep Out</td> <td>Yes</td> </tr> <tr> <td>Normal Mode On, Idle Mode On, Sleep Out</td> <td>Yes</td> </tr> <tr> <td>Sleep In</td> <td>Yes</td> </tr> </tbody> </table>											Status	Availability	Normal Mode On, Idle Mode Off, Sleep Out	Yes	Normal Mode On, Idle Mode On, Sleep Out	Yes	Sleep In	Yes																												
Status	Availability																																														
Normal Mode On, Idle Mode Off, Sleep Out	Yes																																														
Normal Mode On, Idle Mode On, Sleep Out	Yes																																														
Sleep In	Yes																																														
Default	<table border="1" style="margin-left: auto; margin-right: auto;"> <thead> <tr> <th>Status</th> <th>Default Value</th> </tr> </thead> <tbody> <tr> <td>Power On Sequence</td> <td>07h</td> </tr> <tr> <td>S/W Reset</td> <td>07h</td> </tr> <tr> <td>H/W Reset</td> <td>07h</td> </tr> </tbody> </table>											Status	Default Value	Power On Sequence	07h	S/W Reset	07h	H/W Reset	07h																												
Status	Default Value																																														
Power On Sequence	07h																																														
S/W Reset	07h																																														
H/W Reset	07h																																														
Flow Chart	<pre> graph TD A([Idle Mode Color: White]) --> B[/WRIMCOL(80h)/] B --> C[/Parameter 011/] C --> D([Idle Mode Color: Cyan]) </pre>																																														

5.3.41. Read Idle Mode Color (81h)

Command Page		Page 0																																													
Address	Parameter	W/R	D7	D6	D5	D4	D3	D2	D1	D0	Default																																				
81h	1st	R	0	0	0	0	0	R	G	B	07h																																				
Description	<p>81h: RDIMCOL.</p> <p>This command returns the current color selection of Idle Mode, see section "Write Idle Mode Color (80h)".</p> <p>Color selection is defined in the following table:</p> <table border="1" style="margin: 10px auto;"> <thead> <tr> <th>Idle Mode Color Selection</th> <th>R</th> <th>G</th> <th>B</th> </tr> </thead> <tbody> <tr> <td>Black</td> <td>0</td> <td>0</td> <td>0</td> </tr> <tr> <td>Blue</td> <td>0</td> <td>0</td> <td>1</td> </tr> <tr> <td>Green</td> <td>0</td> <td>1</td> <td>0</td> </tr> <tr> <td>Cyan</td> <td>0</td> <td>1</td> <td>1</td> </tr> <tr> <td>Red</td> <td>1</td> <td>0</td> <td>0</td> </tr> <tr> <td>Magenta</td> <td>1</td> <td>0</td> <td>1</td> </tr> <tr> <td>Yellow</td> <td>1</td> <td>1</td> <td>0</td> </tr> <tr> <td>White</td> <td>1</td> <td>1</td> <td>1</td> </tr> </tbody> </table> <p>Default setting for color selection for "Normal Black" panel is 'White'; R=G=B:'1'.</p>											Idle Mode Color Selection	R	G	B	Black	0	0	0	Blue	0	0	1	Green	0	1	0	Cyan	0	1	1	Red	1	0	0	Magenta	1	0	1	Yellow	1	1	0	White	1	1	1
	Idle Mode Color Selection	R	G	B																																											
Black	0	0	0																																												
Blue	0	0	1																																												
Green	0	1	0																																												
Cyan	0	1	1																																												
Red	1	0	0																																												
Magenta	1	0	1																																												
Yellow	1	1	0																																												
White	1	1	1																																												
Restriction	None																																														
Register Availability	<table border="1" style="margin: 10px auto;"> <thead> <tr> <th>Status</th> <th>Availability</th> </tr> </thead> <tbody> <tr> <td>Normal Mode On, Idle Mode Off, Sleep Out</td> <td>Yes</td> </tr> <tr> <td>Normal Mode On, Idle Mode On, Sleep Out</td> <td>Yes</td> </tr> <tr> <td>Sleep In</td> <td>Yes</td> </tr> </tbody> </table>											Status	Availability	Normal Mode On, Idle Mode Off, Sleep Out	Yes	Normal Mode On, Idle Mode On, Sleep Out	Yes	Sleep In	Yes																												
Status	Availability																																														
Normal Mode On, Idle Mode Off, Sleep Out	Yes																																														
Normal Mode On, Idle Mode On, Sleep Out	Yes																																														
Sleep In	Yes																																														
Default	<table border="1" style="margin: 10px auto;"> <thead> <tr> <th>Status</th> <th>Default Value</th> </tr> </thead> <tbody> <tr> <td>Power On Sequence</td> <td>07h</td> </tr> <tr> <td>S/W Reset</td> <td>07h</td> </tr> <tr> <td>H/W Reset</td> <td>07h</td> </tr> </tbody> </table>											Status	Default Value	Power On Sequence	07h	S/W Reset	07h	H/W Reset	07h																												
Status	Default Value																																														
Power On Sequence	07h																																														
S/W Reset	07h																																														
H/W Reset	07h																																														
Flow Chart	<div style="display: flex; align-items: center;"> <div style="flex: 1;"> <pre> graph TD A[Read RDIMCOL] --> B[/Send Parameter/] A -.-> Host Display B </pre> </div> <div style="flex: 0.5; border: 1px dashed gray; padding: 5px;"> <p>Legend</p> <ul style="list-style-type: none"> Command: [] Parameter: / / Display: <> Action: <> Mode: () Sequential transfer: () </div> </div>																																														

5.3.42. Read DDB Start (A1h)

Command Page			Page 0																
Address	Parameter	W/R	D7	D6	D5	D4	D3	D2	D1	D0	Default								
A1h	1st	R	SID[7:0]								0000h								
	2nd	R	SID[15:8]																
	3rd	R	MRID[7:0]								0000h								
	4th	R	MRID[15:8]																
	5th	R	1	1	1	1	1	1	1	1	1	FFh							
Description	<p>A1h: RDDDBS (Read DDB Start).</p> <p>This command reads the supplier identification and display module mode/revision information.</p> <p><i>Note: This information is not the same as which "Read ID1 (DAh)", "Read ID2 (DBh)" and "Read ID3 (DCh)" commands return.</i></p> <p>Parameter 1: SID[7:0] LCD module's manufacturer ID.</p> <p>Parameter 2: SID[15:8] LCD module/driver version ID.</p> <p>Parameter 3: MRID[7:0] LCD module/driver ID.</p> <p>Parameter 4: MRID[15:8] IC version code.</p> <p>Parameter 5: FFh - Exit code – there is no more data in the Descriptor Block</p> <p>This read sequence can be interrupted by any command and it can be continued by the Read DDB Continue (A8h) command. For example, RDDDBS => 1st parameter has been sent => 2nd parameter has been sent => interrupt => RDDDBC => 3rd parameter of the RDDDBS has been sent.</p> <p><i>Note: Maximum DDB data length is 4 bytes with OTP program.</i></p>																		
Restriction	None																		
Register Availability	<table border="1"> <thead> <tr> <th>Status</th> <th>Availability</th> </tr> </thead> <tbody> <tr> <td>Normal Mode On, Idle Mode Off, Sleep Out</td> <td>Yes</td> </tr> <tr> <td>Normal Mode On, Idle Mode On, Sleep Out</td> <td>Yes</td> </tr> <tr> <td>Sleep In</td> <td>Yes</td> </tr> </tbody> </table>											Status	Availability	Normal Mode On, Idle Mode Off, Sleep Out	Yes	Normal Mode On, Idle Mode On, Sleep Out	Yes	Sleep In	Yes
Status	Availability																		
Normal Mode On, Idle Mode Off, Sleep Out	Yes																		
Normal Mode On, Idle Mode On, Sleep Out	Yes																		
Sleep In	Yes																		
Default	<table border="1"> <thead> <tr> <th>Status</th> <th>Default Value</th> </tr> </thead> <tbody> <tr> <td>Power On Sequence</td> <td>00h_00h_00h_00h_FFh</td> </tr> <tr> <td>S/W Reset</td> <td>00h_00h_00h_00h_FFh</td> </tr> <tr> <td>H/W Reset</td> <td>00h_00h_00h_00h_FFh</td> </tr> </tbody> </table>											Status	Default Value	Power On Sequence	00h_00h_00h_00h_FFh	S/W Reset	00h_00h_00h_00h_FFh	H/W Reset	00h_00h_00h_00h_FFh
Status	Default Value																		
Power On Sequence	00h_00h_00h_00h_FFh																		
S/W Reset	00h_00h_00h_00h_FFh																		
H/W Reset	00h_00h_00h_00h_FFh																		

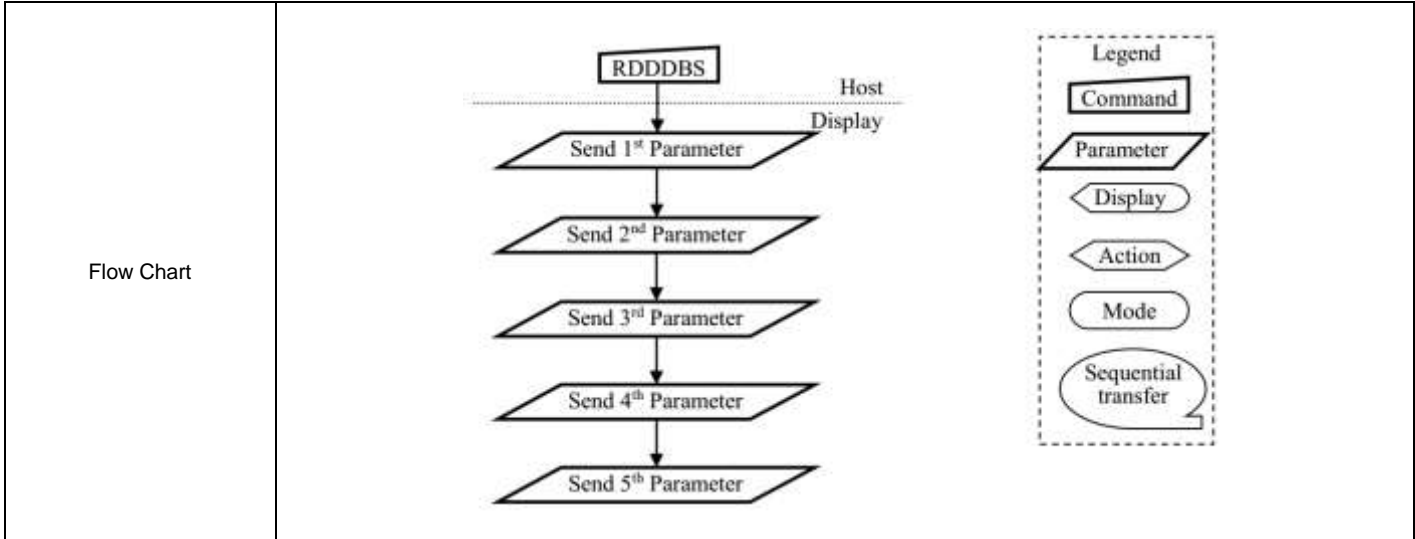

5.3.43. Read DDB Continue (A8h)

Command Page			Page 0																
Address	Parameter	W/R	D7	D6	D5	D4	D3	D2	D1	D0	Default								
A8h	1st	R	D1[7:0]									00h							
	2nd	R	D2[7:0]									00h							
	:	R	:									00h							
	Nth	R	Dn[7:0]									00h							
Description		A8h: RDDDBC (Read DDB Continue). This command is used to read the supplier's identification and revision information from the point where RDDDBS (A1h) was interrupted by another command																	
Restriction		None																	
Register Availability		<table border="1"> <thead> <tr> <th>Status</th> <th>Availability</th> </tr> </thead> <tbody> <tr> <td>Normal Mode On, Idle Mode Off, Sleep Out</td> <td>Yes</td> </tr> <tr> <td>Normal Mode On, Idle Mode On, Sleep Out</td> <td>Yes</td> </tr> <tr> <td>Sleep In</td> <td>Yes</td> </tr> </tbody> </table>										Status	Availability	Normal Mode On, Idle Mode Off, Sleep Out	Yes	Normal Mode On, Idle Mode On, Sleep Out	Yes	Sleep In	Yes
Status	Availability																		
Normal Mode On, Idle Mode Off, Sleep Out	Yes																		
Normal Mode On, Idle Mode On, Sleep Out	Yes																		
Sleep In	Yes																		
Default		<table border="1"> <thead> <tr> <th>Status</th> <th>Default Value</th> </tr> </thead> <tbody> <tr> <td>Power On Sequence</td> <td>00h</td> </tr> <tr> <td>S/W Reset</td> <td>00h</td> </tr> <tr> <td>H/W Reset</td> <td>00h</td> </tr> </tbody> </table>										Status	Default Value	Power On Sequence	00h	S/W Reset	00h	H/W Reset	00h
Status	Default Value																		
Power On Sequence	00h																		
S/W Reset	00h																		
H/W Reset	00h																		
Flow Chart																			

5.3.44. Read First Checksum (AAh)

Command Page			Page 0																
Address	Parameter	W/R	D7	D6	D5	D4	D3	D2	D1	D0	Default								
AAh	1st	R	FCS[7:0]									00h							
Description	AAh: RDFCS (Read First Checksum). This command returns the first checksum what has been calculated from Page 0 area registers after the write access to those registers has been done.																		
Restriction	It will be necessary to wait 150ms after there is the last write access on Page 0 area registers before there can read this checksum value.																		
Register Availability	<table border="1"> <thead> <tr> <th>Status</th> <th>Availability</th> </tr> </thead> <tbody> <tr> <td>Normal Mode On, Idle Mode Off, Sleep Out</td> <td>Yes</td> </tr> <tr> <td>Normal Mode On, Idle Mode On, Sleep Out</td> <td>Yes</td> </tr> <tr> <td>Sleep In</td> <td>Yes</td> </tr> </tbody> </table>											Status	Availability	Normal Mode On, Idle Mode Off, Sleep Out	Yes	Normal Mode On, Idle Mode On, Sleep Out	Yes	Sleep In	Yes
Status	Availability																		
Normal Mode On, Idle Mode Off, Sleep Out	Yes																		
Normal Mode On, Idle Mode On, Sleep Out	Yes																		
Sleep In	Yes																		
Default	<table border="1"> <thead> <tr> <th>Status</th> <th>Default Value</th> </tr> </thead> <tbody> <tr> <td>Power On Sequence</td> <td>00h</td> </tr> <tr> <td>S/W Reset</td> <td>00h</td> </tr> <tr> <td>H/W Reset</td> <td>00h</td> </tr> </tbody> </table>											Status	Default Value	Power On Sequence	00h	S/W Reset	00h	H/W Reset	00h
Status	Default Value																		
Power On Sequence	00h																		
S/W Reset	00h																		
H/W Reset	00h																		
Flow Chart																			

5.3.45. Read Continue Checksum (AFh)

Command Page		Page 0																	
Address	Parameter	W/R	D7	D6	D5	D4	D3	D2	D1	D0	Default								
AFh	1st	R	CCS[7:0]								00h								
Description	AFh: RDCCS (Read Continue Checksum). This command returns the continue checksum what has been calculated continuously after the first checksum has calculated from Page 0 area registers after the write access to those registers has been done.																		
Restriction	It will be necessary to wait 300ms after there is the last write access on Page 0 area registers before there can read this checksum value in the first time.																		
Register Availability	<table border="1"> <thead> <tr> <th>Status</th> <th>Availability</th> </tr> </thead> <tbody> <tr> <td>Normal Mode On, Idle Mode Off, Sleep Out</td> <td>Yes</td> </tr> <tr> <td>Normal Mode On, Idle Mode On, Sleep Out</td> <td>Yes</td> </tr> <tr> <td>Sleep In</td> <td>Yes</td> </tr> </tbody> </table>											Status	Availability	Normal Mode On, Idle Mode Off, Sleep Out	Yes	Normal Mode On, Idle Mode On, Sleep Out	Yes	Sleep In	Yes
Status	Availability																		
Normal Mode On, Idle Mode Off, Sleep Out	Yes																		
Normal Mode On, Idle Mode On, Sleep Out	Yes																		
Sleep In	Yes																		
Default	<table border="1"> <thead> <tr> <th>Status</th> <th>Default Value</th> </tr> </thead> <tbody> <tr> <td>Power On Sequence</td> <td>00h</td> </tr> <tr> <td>S/W Reset</td> <td>00h</td> </tr> <tr> <td>H/W Reset</td> <td>00h</td> </tr> </tbody> </table>											Status	Default Value	Power On Sequence	00h	S/W Reset	00h	H/W Reset	00h
Status	Default Value																		
Power On Sequence	00h																		
S/W Reset	00h																		
H/W Reset	00h																		
Flow Chart																			

5.3.46. Read ID1 (DAh)

Command Page			Page 0																
Address	Parameter	W/R	D7	D6	D5	D4	D3	D2	D1	D0	Default								
DAh	1st	R	ID1[7:0]								00h								
Description		Dah: RDID1 (Read ID1). This read byte identifies the display module's manufacturer. The ID1[7:0] is programmed by the OTP function.																	
Restriction		None																	
Register Availability		<table border="1" style="margin-left: auto; margin-right: auto;"> <thead> <tr> <th>Status</th> <th>Availability</th> </tr> </thead> <tbody> <tr> <td>Normal Mode On, Idle Mode Off, Sleep Out</td> <td>Yes</td> </tr> <tr> <td>Normal Mode On, Idle Mode On, Sleep Out</td> <td>Yes</td> </tr> <tr> <td>Sleep In</td> <td>Yes</td> </tr> </tbody> </table>										Status	Availability	Normal Mode On, Idle Mode Off, Sleep Out	Yes	Normal Mode On, Idle Mode On, Sleep Out	Yes	Sleep In	Yes
Status	Availability																		
Normal Mode On, Idle Mode Off, Sleep Out	Yes																		
Normal Mode On, Idle Mode On, Sleep Out	Yes																		
Sleep In	Yes																		
Default		<table border="1" style="margin-left: auto; margin-right: auto;"> <thead> <tr> <th>Status</th> <th>Default Value</th> </tr> </thead> <tbody> <tr> <td>Power On Sequence</td> <td>00h</td> </tr> <tr> <td>S/W Reset</td> <td>00h</td> </tr> <tr> <td>H/W Reset</td> <td>00h</td> </tr> </tbody> </table>										Status	Default Value	Power On Sequence	00h	S/W Reset	00h	H/W Reset	00h
Status	Default Value																		
Power On Sequence	00h																		
S/W Reset	00h																		
H/W Reset	00h																		
Flow Chart																			

5.3.47. Read ID2 (DBh)

Command Page			Page 0																
Address	Parameter	W/R	D7	D6	D5	D4	D3	D2	D1	D0	Default								
DBh	1st	R	ID2[7:0]								00h								
Description	<p>DBh: RDID2 (Read ID2).</p> <p>This read byte is used to track the display module/driver version. It is defined by display supplier (with User's agreement) and changes each time a revision is made to the display, material or construction specifications.</p> <p>The ID2[7:0] is programmed by the OTP function.</p>																		
Restriction	None																		
Register Availability	<table border="1"> <thead> <tr> <th>Status</th> <th>Availability</th> </tr> </thead> <tbody> <tr> <td>Normal Mode On, Idle Mode Off, Sleep Out</td> <td>Yes</td> </tr> <tr> <td>Normal Mode On, Idle Mode On, Sleep Out</td> <td>Yes</td> </tr> <tr> <td>Sleep In</td> <td>Yes</td> </tr> </tbody> </table>											Status	Availability	Normal Mode On, Idle Mode Off, Sleep Out	Yes	Normal Mode On, Idle Mode On, Sleep Out	Yes	Sleep In	Yes
Status	Availability																		
Normal Mode On, Idle Mode Off, Sleep Out	Yes																		
Normal Mode On, Idle Mode On, Sleep Out	Yes																		
Sleep In	Yes																		
Default	<table border="1"> <thead> <tr> <th>Status</th> <th>Default Value</th> </tr> </thead> <tbody> <tr> <td>Power On Sequence</td> <td>00h</td> </tr> <tr> <td>S/W Reset</td> <td>00h</td> </tr> <tr> <td>H/W Reset</td> <td>00h</td> </tr> </tbody> </table>											Status	Default Value	Power On Sequence	00h	S/W Reset	00h	H/W Reset	00h
Status	Default Value																		
Power On Sequence	00h																		
S/W Reset	00h																		
H/W Reset	00h																		
Flow Chart																			

5.3.48. Read ID3 (DCh)

Command Page			Page 0																
Address	Parameter	W/R	D7	D6	D5	D4	D3	D2	D1	D0	Default								
DCh	1st	R	ID3[7:0]								00h								
Description	DCh: RDID3 (Read ID3). This read byte identifies the display module/driver. The ID3[7:0] is programmed by the OTP function.																		
Restriction	None																		
Register Availability	<table border="1" style="margin-left: auto; margin-right: auto;"> <thead> <tr> <th>Status</th> <th>Availability</th> </tr> </thead> <tbody> <tr> <td>Normal Mode On, Idle Mode Off, Sleep Out</td> <td>Yes</td> </tr> <tr> <td>Normal Mode On, Idle Mode On, Sleep Out</td> <td>Yes</td> </tr> <tr> <td>Sleep In</td> <td>Yes</td> </tr> </tbody> </table>											Status	Availability	Normal Mode On, Idle Mode Off, Sleep Out	Yes	Normal Mode On, Idle Mode On, Sleep Out	Yes	Sleep In	Yes
Status	Availability																		
Normal Mode On, Idle Mode Off, Sleep Out	Yes																		
Normal Mode On, Idle Mode On, Sleep Out	Yes																		
Sleep In	Yes																		
Default	<table border="1" style="margin-left: auto; margin-right: auto;"> <thead> <tr> <th>Status</th> <th>Default Value</th> </tr> </thead> <tbody> <tr> <td>Power On Sequence</td> <td>00h</td> </tr> <tr> <td>S/W Reset</td> <td>00h</td> </tr> <tr> <td>H/W Reset</td> <td>00h</td> </tr> </tbody> </table>											Status	Default Value	Power On Sequence	00h	S/W Reset	00h	H/W Reset	00h
Status	Default Value																		
Power On Sequence	00h																		
S/W Reset	00h																		
H/W Reset	00h																		
Flow Chart	<div style="display: flex; align-items: center; justify-content: center;"> <div style="text-align: center; margin-right: 20px;"> <p>Read ID3</p> <p>↓</p> <p>Send Parameter</p> </div> <div style="text-align: center; margin-right: 20px;"> <p>Host</p> <hr style="width: 50%; margin: 0 auto;"/> <p>Display</p> </div> <div style="border: 1px dashed black; padding: 5px;"> <p>Legend</p> <ul style="list-style-type: none"> Command: Parameter: Display: Action: Mode: Sequential transfer: </div> </div>																		

5.3.49. EXTC Command Set Enable Register (FFh)

Command Page			Page 0																																		
Address	Parameter	W/R	D7	D6	D5	D4	D3	D2	D1	D0	Default																										
FFh	1st	W	1	0	0	1	1	0	0	0	98h																										
	2nd	W	1	0	0	0	0	0	0	1	81h																										
	3rd	W	PAGE[7:0]								00h																										
Description	<p>PAGE[7:0]: Set the command page.</p> <table border="1"> <thead> <tr> <th>PAGE[7:0]</th> <th>Command Page</th> </tr> </thead> <tbody> <tr><td>00h</td><td>Page 0</td></tr> <tr><td>01h</td><td>Page 1</td></tr> <tr><td>02h</td><td>Page 2</td></tr> <tr><td>03h</td><td>Page 3</td></tr> <tr><td>04h</td><td>Page 4</td></tr> <tr><td>05h</td><td>Page 5</td></tr> <tr><td>06h</td><td>Page 6</td></tr> <tr><td>07h</td><td>Page 7</td></tr> <tr><td>08h</td><td>Page 8</td></tr> <tr><td>09h</td><td>Page 9</td></tr> <tr><td>0Ah</td><td>Page 10</td></tr> <tr><td>Others</td><td>Reserved</td></tr> </tbody> </table> <p>Set the register, 1st Parameter = 98h, 2nd Parameter = 81h, 3rd Parameter = Page value to enable "Page command set" available</p> <p>See section "5.1 Command Flow".</p>											PAGE[7:0]	Command Page	00h	Page 0	01h	Page 1	02h	Page 2	03h	Page 3	04h	Page 4	05h	Page 5	06h	Page 6	07h	Page 7	08h	Page 8	09h	Page 9	0Ah	Page 10	Others	Reserved
	PAGE[7:0]	Command Page																																			
	00h	Page 0																																			
	01h	Page 1																																			
	02h	Page 2																																			
	03h	Page 3																																			
	04h	Page 4																																			
	05h	Page 5																																			
	06h	Page 6																																			
	07h	Page 7																																			
	08h	Page 8																																			
	09h	Page 9																																			
	0Ah	Page 10																																			
Others	Reserved																																				
Restriction	None																																				
Register Availability	<table border="1"> <thead> <tr> <th>Status</th> <th>Availability</th> </tr> </thead> <tbody> <tr> <td>Normal Mode On, Idle Mode Off, Sleep Out</td> <td>Yes</td> </tr> <tr> <td>Normal Mode On, Idle Mode On, Sleep Out</td> <td>Yes</td> </tr> <tr> <td>Sleep In</td> <td>Yes</td> </tr> </tbody> </table>											Status	Availability	Normal Mode On, Idle Mode Off, Sleep Out	Yes	Normal Mode On, Idle Mode On, Sleep Out	Yes	Sleep In	Yes																		
Status	Availability																																				
Normal Mode On, Idle Mode Off, Sleep Out	Yes																																				
Normal Mode On, Idle Mode On, Sleep Out	Yes																																				
Sleep In	Yes																																				
Default	<table border="1"> <thead> <tr> <th>Status</th> <th>Default Value</th> </tr> </thead> <tbody> <tr> <td>Power On Sequence</td> <td>00h</td> </tr> <tr> <td>S/W Reset</td> <td>00h</td> </tr> <tr> <td>H/W Reset</td> <td>00h</td> </tr> </tbody> </table>											Status	Default Value	Power On Sequence	00h	S/W Reset	00h	H/W Reset	00h																		
Status	Default Value																																				
Power On Sequence	00h																																				
S/W Reset	00h																																				
H/W Reset	00h																																				

5.4. Page 1 Command Description

5.4.1. Read ID4 (00h~02h)

Command Page			Page 1																
Address	Parameter	W/R	D7	D6	D5	D4	D3	D2	D1	D0	Default								
00h	1st	R	ID4[23:16]								98h								
01h	1st	R	ID4[15:8]								81h								
02h	1st	R	ID4[7:0]								1Ch								
Description		ID4[23:0] : mean the IC model name.																	
Restriction		None																	
Register Availability		<table border="1"> <thead> <tr> <th>Status</th> <th>Availability</th> </tr> </thead> <tbody> <tr> <td>Normal Mode On, Idle Mode Off, Sleep Out</td> <td>Yes</td> </tr> <tr> <td>Normal Mode On, Idle Mode On, Sleep Out</td> <td>Yes</td> </tr> <tr> <td>Sleep In</td> <td>Yes</td> </tr> </tbody> </table>										Status	Availability	Normal Mode On, Idle Mode Off, Sleep Out	Yes	Normal Mode On, Idle Mode On, Sleep Out	Yes	Sleep In	Yes
Status	Availability																		
Normal Mode On, Idle Mode Off, Sleep Out	Yes																		
Normal Mode On, Idle Mode On, Sleep Out	Yes																		
Sleep In	Yes																		
Default		<table border="1"> <thead> <tr> <th>Status</th> <th>Default Value</th> </tr> </thead> <tbody> <tr> <td>Power On Sequence</td> <td>98h_81h_1Ch</td> </tr> <tr> <td>S/W Reset</td> <td>98h_81h_1Ch</td> </tr> <tr> <td>H/W Reset</td> <td>98h_81h_1Ch</td> </tr> </tbody> </table>										Status	Default Value	Power On Sequence	98h_81h_1Ch	S/W Reset	98h_81h_1Ch	H/W Reset	98h_81h_1Ch
Status	Default Value																		
Power On Sequence	98h_81h_1Ch																		
S/W Reset	98h_81h_1Ch																		
H/W Reset	98h_81h_1Ch																		

5.4.2. Set Panel Operation Mode and Data Complement Setting (22h)

Command Page		Page 1																																																
Address	Parameter	W/R	D7	D6	D5	D4	D3	D2	D1	D0	Default																																							
22h	1st	W/R	0	0	EPF[1:0]		BGR_PA NEL	REV_PA NEL	SS_PAN EL	GS_PAN EL	30h																																							
Description	<p>This command defines the panel operation mode</p> <p>EPF[1:0]: Set the data format from 16/18-bit (R,G,B) to 24-bit (r, g, b) that is mapping into the internal circuit. See section “4.2.2 16/18-bit Color Data Mapping to 24-bit Pixel Data Operation” for detail description.</p> <p>BGR_PANEL:</p> <table border="1"> <thead> <tr> <th>Symbol</th> <th>Name</th> <th>Description</th> </tr> </thead> <tbody> <tr> <td>BGR_PANEL</td> <td>Panel RGB-BGR Order</td> <td>Color selector switch control (0=RGB color filter panel, 1=BGR color filter panel)</td> </tr> </tbody> </table> <p>REV_PANEL: Normally white or normally black panel select.</p> <table border="1"> <thead> <tr> <th>REV_PANEL</th> <th>Panel</th> <th>Data</th> <th>Color</th> <th>Source</th> </tr> </thead> <tbody> <tr> <td rowspan="2">0</td> <td rowspan="2">Normally black</td> <td>0x00</td> <td>Black</td> <td>Smallest gamma voltage</td> </tr> <tr> <td>0xFF</td> <td>White</td> <td>Largest gamma voltage</td> </tr> <tr> <td rowspan="2">1</td> <td rowspan="2">normally white</td> <td>0x00</td> <td>Black</td> <td>Largest gamma voltage</td> </tr> <tr> <td>0xFF</td> <td>White</td> <td>Smallest gamma voltage</td> </tr> </tbody> </table> <p>SS_PANEL: Select the shift direction of outputs from the source driver.</p> <table border="1"> <thead> <tr> <th>SS_PANEL</th> <th>Source Output Scan Direction</th> </tr> </thead> <tbody> <tr> <td>0</td> <td>Forward</td> </tr> <tr> <td>1</td> <td>Backward</td> </tr> </tbody> </table> <p>GS_PANEL: Select the shift direction of outputs from the gate driver.</p> <table border="1"> <thead> <tr> <th>GS_PANEL</th> <th>Gate Output Scan Direction</th> </tr> </thead> <tbody> <tr> <td>0</td> <td>Top → Bottom</td> </tr> <tr> <td>1</td> <td>Bottom → Top</td> </tr> </tbody> </table>											Symbol	Name	Description	BGR_PANEL	Panel RGB-BGR Order	Color selector switch control (0=RGB color filter panel, 1=BGR color filter panel)	REV_PANEL	Panel	Data	Color	Source	0	Normally black	0x00	Black	Smallest gamma voltage	0xFF	White	Largest gamma voltage	1	normally white	0x00	Black	Largest gamma voltage	0xFF	White	Smallest gamma voltage	SS_PANEL	Source Output Scan Direction	0	Forward	1	Backward	GS_PANEL	Gate Output Scan Direction	0	Top → Bottom	1	Bottom → Top
	Symbol	Name	Description																																															
BGR_PANEL	Panel RGB-BGR Order	Color selector switch control (0=RGB color filter panel, 1=BGR color filter panel)																																																
REV_PANEL	Panel	Data	Color	Source																																														
0	Normally black	0x00	Black	Smallest gamma voltage																																														
		0xFF	White	Largest gamma voltage																																														
1	normally white	0x00	Black	Largest gamma voltage																																														
		0xFF	White	Smallest gamma voltage																																														
SS_PANEL	Source Output Scan Direction																																																	
0	Forward																																																	
1	Backward																																																	
GS_PANEL	Gate Output Scan Direction																																																	
0	Top → Bottom																																																	
1	Bottom → Top																																																	
Restriction	None																																																	
Register Availability	<table border="1"> <thead> <tr> <th>Status</th> <th>Availability</th> </tr> </thead> <tbody> <tr> <td>Normal Mode On, Idle Mode Off, Sleep Out</td> <td>Yes</td> </tr> <tr> <td>Normal Mode On, Idle Mode On, Sleep Out</td> <td>Yes</td> </tr> <tr> <td>Sleep In</td> <td>Yes</td> </tr> </tbody> </table>											Status	Availability	Normal Mode On, Idle Mode Off, Sleep Out	Yes	Normal Mode On, Idle Mode On, Sleep Out	Yes	Sleep In	Yes																															
Status	Availability																																																	
Normal Mode On, Idle Mode Off, Sleep Out	Yes																																																	
Normal Mode On, Idle Mode On, Sleep Out	Yes																																																	
Sleep In	Yes																																																	
Default	<table border="1"> <thead> <tr> <th>Status</th> <th>Default Value (Before OTP program)</th> </tr> </thead> <tbody> <tr> <td>Power On Sequence</td> <td>30h</td> </tr> <tr> <td>S/W Reset</td> <td>30h</td> </tr> <tr> <td>H/W Reset</td> <td>30h</td> </tr> </tbody> </table>											Status	Default Value (Before OTP program)	Power On Sequence	30h	S/W Reset	30h	H/W Reset	30h																															
Status	Default Value (Before OTP program)																																																	
Power On Sequence	30h																																																	
S/W Reset	30h																																																	
H/W Reset	30h																																																	

5.4.3. Blanking Porch Control (25h~26h)

Command Page			Page 1																														
Address	Parameter	W/R	D7	D6	D5	D4	D3	D2	D1	D0	Default																						
25h	1st	W/R	VFP[7:0]								14h																						
26h	1st	W/R	VBP[7:0]								14h																						
Description	<p>VFP[7:0] / VBP[7:0]: The VFP[7:0] and VBP[7:0] bits specify the line number of vertical front and back porch period respectively in the Idle Mode.</p> <table border="1"> <thead> <tr> <th>VFP[7:0] VBP[7:0]</th> <th>Number of HSYNC of front/back porch (Dec.)</th> </tr> </thead> <tbody> <tr> <td>00000000</td> <td>Setting prohibited</td> </tr> <tr> <td>00000001</td> <td>Setting prohibited</td> </tr> <tr> <td>00000010</td> <td>2</td> </tr> <tr> <td>00000011</td> <td>3</td> </tr> <tr> <td>:</td> <td>:</td> </tr> <tr> <td>00001110</td> <td>14 (VFP[7:0] /VBP[7:0] default)</td> </tr> <tr> <td>:</td> <td>:</td> </tr> <tr> <td>11111101</td> <td>253</td> </tr> <tr> <td>11111110</td> <td>254</td> </tr> <tr> <td>11111111</td> <td>255</td> </tr> </tbody> </table>											VFP[7:0] VBP[7:0]	Number of HSYNC of front/back porch (Dec.)	00000000	Setting prohibited	00000001	Setting prohibited	00000010	2	00000011	3	:	:	00001110	14 (VFP[7:0] /VBP[7:0] default)	:	:	11111101	253	11111110	254	11111111	255
	VFP[7:0] VBP[7:0]	Number of HSYNC of front/back porch (Dec.)																															
	00000000	Setting prohibited																															
	00000001	Setting prohibited																															
	00000010	2																															
	00000011	3																															
	:	:																															
	00001110	14 (VFP[7:0] /VBP[7:0] default)																															
	:	:																															
	11111101	253																															
	11111110	254																															
	11111111	255																															
Restriction	None																																
Register Availability	<table border="1"> <thead> <tr> <th>Status</th> <th>Availability</th> </tr> </thead> <tbody> <tr> <td>Normal Mode On, Idle Mode Off, Sleep Out</td> <td>Yes</td> </tr> <tr> <td>Normal Mode On, Idle Mode On, Sleep Out</td> <td>Yes</td> </tr> <tr> <td>Sleep In</td> <td>Yes</td> </tr> </tbody> </table>											Status	Availability	Normal Mode On, Idle Mode Off, Sleep Out	Yes	Normal Mode On, Idle Mode On, Sleep Out	Yes	Sleep In	Yes														
Status	Availability																																
Normal Mode On, Idle Mode Off, Sleep Out	Yes																																
Normal Mode On, Idle Mode On, Sleep Out	Yes																																
Sleep In	Yes																																
Default	<table border="1"> <thead> <tr> <th>Status</th> <th>Default Value</th> </tr> </thead> <tbody> <tr> <td>Power On Sequence</td> <td>14h_14h</td> </tr> <tr> <td>S/W Reset</td> <td>14h_14h</td> </tr> <tr> <td>H/W Reset</td> <td>14h_14h</td> </tr> </tbody> </table>											Status	Default Value	Power On Sequence	14h_14h	S/W Reset	14h_14h	H/W Reset	14h_14h														
Status	Default Value																																
Power On Sequence	14h_14h																																
S/W Reset	14h_14h																																
H/W Reset	14h_14h																																

5.4.4. Touch Synchronization Control (29h)

Command Page			Page 1																
Address	Parameter	W/R	D7	D6	D5	D4	D3	D2	D1	D0	Default								
29h	1st	W/R	0	0	0	0	0	0	0	TOUCH_VHSYNC	00h								
Description		TOUCH_VHSYNC: Enable VSOUT / HSOUT signal output.																	
Restriction		None																	
Register Availability		<table border="1"> <thead> <tr> <th>Status</th> <th>Availability</th> </tr> </thead> <tbody> <tr> <td>Normal Mode On, Idle Mode Off, Sleep Out</td> <td>Yes</td> </tr> <tr> <td>Normal Mode On, Idle Mode On, Sleep Out</td> <td>Yes</td> </tr> <tr> <td>Sleep In</td> <td>Yes</td> </tr> </tbody> </table>										Status	Availability	Normal Mode On, Idle Mode Off, Sleep Out	Yes	Normal Mode On, Idle Mode On, Sleep Out	Yes	Sleep In	Yes
Status	Availability																		
Normal Mode On, Idle Mode Off, Sleep Out	Yes																		
Normal Mode On, Idle Mode On, Sleep Out	Yes																		
Sleep In	Yes																		
Default		<table border="1"> <thead> <tr> <th>Status</th> <th>Default Value</th> </tr> </thead> <tbody> <tr> <td>Power On Sequence</td> <td>00h</td> </tr> <tr> <td>S/W Reset</td> <td>00h</td> </tr> <tr> <td>H/W Reset</td> <td>00h</td> </tr> </tbody> </table>										Status	Default Value	Power On Sequence	00h	S/W Reset	00h	H/W Reset	00h
Status	Default Value																		
Power On Sequence	00h																		
S/W Reset	00h																		
H/W Reset	00h																		

5.4.5. Gate Number (2Eh)

Command Page			Page 1																														
Address	Parameter	W/R	D7	D6	D5	D4	D3	D2	D1	D0	Default																						
2Eh	1st	W/R	NL[7:0]								C8h																						
Description	<p>NL[7:0]: Set the number of lines to drive the LCD at an interval of 4 lines. The number of lines must be the same or more than the number of lines necessary for the size of the LCD panel.</p> <table border="1"> <thead> <tr> <th>NL[7:0]</th> <th>The Line Number of the LCD</th> </tr> </thead> <tbody> <tr><td>00h</td><td>480</td></tr> <tr><td>01h</td><td>484</td></tr> <tr><td>02h</td><td>488</td></tr> <tr><td>03h</td><td>492</td></tr> <tr><td>:</td><td>:</td></tr> <tr><td>C5h</td><td>1268</td></tr> <tr><td>C6h</td><td>1272</td></tr> <tr><td>C7h</td><td>1276</td></tr> <tr><td>C8h</td><td>1280</td></tr> <tr><td>Others</td><td>Reserved</td></tr> </tbody> </table>											NL[7:0]	The Line Number of the LCD	00h	480	01h	484	02h	488	03h	492	:	:	C5h	1268	C6h	1272	C7h	1276	C8h	1280	Others	Reserved
	NL[7:0]	The Line Number of the LCD																															
	00h	480																															
	01h	484																															
	02h	488																															
	03h	492																															
	:	:																															
	C5h	1268																															
	C6h	1272																															
	C7h	1276																															
C8h	1280																																
Others	Reserved																																
Restriction	None																																
Register Availability	<table border="1"> <thead> <tr> <th>Status</th> <th>Availability</th> </tr> </thead> <tbody> <tr> <td>Normal Mode On, Idle Mode Off, Sleep Out</td> <td>Yes</td> </tr> <tr> <td>Normal Mode On, Idle Mode On, Sleep Out</td> <td>Yes</td> </tr> <tr> <td>Sleep In</td> <td>Yes</td> </tr> </tbody> </table>											Status	Availability	Normal Mode On, Idle Mode Off, Sleep Out	Yes	Normal Mode On, Idle Mode On, Sleep Out	Yes	Sleep In	Yes														
Status	Availability																																
Normal Mode On, Idle Mode Off, Sleep Out	Yes																																
Normal Mode On, Idle Mode On, Sleep Out	Yes																																
Sleep In	Yes																																
Default	<table border="1"> <thead> <tr> <th>Status</th> <th>Default Value</th> </tr> </thead> <tbody> <tr> <td>Power On Sequence</td> <td>C8h</td> </tr> <tr> <td>S/W Reset</td> <td>C8h</td> </tr> <tr> <td>H/W Reset</td> <td>C8h</td> </tr> </tbody> </table>											Status	Default Value	Power On Sequence	C8h	S/W Reset	C8h	H/W Reset	C8h														
Status	Default Value																																
Power On Sequence	C8h																																
S/W Reset	C8h																																
H/W Reset	C8h																																

5.4.6. Display Inversion Control (31h)

Command Page		Page 1																																																																																																																																																																																																															
Address	Parameter	W/R	D7	D6	D5	D4	D3	D2	D1	D0	Default																																																																																																																																																																																																						
31h	1st	W/R	0	0	0	0	DINV[3:0]				00h																																																																																																																																																																																																						
Description	<p>DINV[3:0]: Set Inversion mode</p> <table border="1"> <thead> <tr> <th>DINV[3:0]</th> <th>Inversion</th> </tr> </thead> <tbody> <tr><td>0h</td><td>Column inversion</td></tr> <tr><td>1h</td><td>1-dot inversion</td></tr> <tr><td>2h</td><td>2-dot inversion</td></tr> <tr><td>3h</td><td>3-dot inversion</td></tr> <tr><td>4h</td><td>4-dot inversion</td></tr> <tr><td>5h</td><td>N/4-dot inversion ^{Note}</td></tr> <tr><td>6h</td><td>N/8-dot inversion ^{Note}</td></tr> <tr><td>7h</td><td>N/16-dot inversion ^{Note}</td></tr> <tr><td>8h</td><td>N/32-dot inversion ^{Note}</td></tr> <tr><td>9h</td><td>Zig-Zag inversion Type 1</td></tr> <tr><td>Ah</td><td>Zig-Zag inversion Type 2</td></tr> <tr><td>Bh</td><td>Zig-Zag inversion Type 3</td></tr> <tr><td>Ch</td><td>Zig-Zag inversion Type 4</td></tr> <tr><td>Others</td><td>Reserved</td></tr> </tbody> </table> <p><i>Note : N=The line number of the LCD (setting by NL[7:0])</i></p> <p style="text-align: center;">Column Inversion</p> <div style="display: flex; justify-content: space-around;"> <div style="text-align: center;"> <p>1st frame</p> <table border="1"> <tr><td>1 line</td><td>+</td><td>-</td><td>+</td><td>-</td><td>+</td><td>-</td></tr> <tr><td>2 line</td><td>+</td><td>-</td><td>+</td><td>-</td><td>+</td><td>-</td></tr> <tr><td>3 line</td><td>+</td><td>-</td><td>+</td><td>-</td><td>+</td><td>-</td></tr> <tr><td>4 line</td><td>+</td><td>-</td><td>+</td><td>-</td><td>+</td><td>-</td></tr> </table> </div> <div style="font-size: 2em;">→</div> <div style="text-align: center;"> <p>2nd frame</p> <table border="1"> <tr><td>1 line</td><td>-</td><td>+</td><td>-</td><td>+</td><td>-</td><td>+</td></tr> <tr><td>2 line</td><td>-</td><td>+</td><td>-</td><td>+</td><td>-</td><td>+</td></tr> <tr><td>3 line</td><td>-</td><td>+</td><td>-</td><td>+</td><td>-</td><td>+</td></tr> <tr><td>4 line</td><td>-</td><td>+</td><td>-</td><td>+</td><td>-</td><td>+</td></tr> </table> </div> </div> <p style="text-align: center;">1-Dot Inversion</p> <div style="display: flex; justify-content: space-around;"> <div style="text-align: center;"> <p>1st frame</p> <table border="1"> <tr><td>1 line</td><td>+</td><td>-</td><td>+</td><td>-</td><td>+</td><td>-</td></tr> <tr><td>2 line</td><td>-</td><td>+</td><td>-</td><td>+</td><td>-</td><td>+</td></tr> <tr><td>3 line</td><td>+</td><td>-</td><td>+</td><td>-</td><td>+</td><td>-</td></tr> <tr><td>4 line</td><td>-</td><td>+</td><td>-</td><td>+</td><td>-</td><td>+</td></tr> </table> </div> <div style="font-size: 2em;">→</div> <div style="text-align: center;"> <p>2nd frame</p> <table border="1"> <tr><td>1 line</td><td>-</td><td>+</td><td>-</td><td>+</td><td>-</td><td>+</td></tr> <tr><td>2 line</td><td>+</td><td>-</td><td>+</td><td>-</td><td>+</td><td>-</td></tr> <tr><td>3 line</td><td>-</td><td>+</td><td>-</td><td>+</td><td>-</td><td>+</td></tr> <tr><td>4 line</td><td>+</td><td>-</td><td>+</td><td>-</td><td>+</td><td>-</td></tr> </table> </div> </div> <p style="text-align: center;">2-Dot Inversion</p> <div style="display: flex; justify-content: space-around;"> <div style="text-align: center;"> <p>1st frame</p> <table border="1"> <tr><td>1 line</td><td>+</td><td>-</td><td>+</td><td>-</td><td>+</td><td>-</td></tr> <tr><td>2 line</td><td>+</td><td>-</td><td>+</td><td>-</td><td>+</td><td>-</td></tr> <tr><td>3 line</td><td>-</td><td>+</td><td>-</td><td>+</td><td>-</td><td>+</td></tr> <tr><td>4 line</td><td>-</td><td>+</td><td>-</td><td>+</td><td>-</td><td>+</td></tr> </table> </div> <div style="font-size: 2em;">→</div> <div style="text-align: center;"> <p>2nd frame</p> <table border="1"> <tr><td>1 line</td><td>-</td><td>+</td><td>-</td><td>+</td><td>-</td><td>+</td></tr> <tr><td>2 line</td><td>-</td><td>+</td><td>-</td><td>+</td><td>-</td><td>+</td></tr> <tr><td>3 line</td><td>+</td><td>-</td><td>+</td><td>-</td><td>+</td><td>-</td></tr> <tr><td>4 line</td><td>+</td><td>-</td><td>+</td><td>-</td><td>+</td><td>-</td></tr> </table> </div> </div>											DINV[3:0]	Inversion	0h	Column inversion	1h	1-dot inversion	2h	2-dot inversion	3h	3-dot inversion	4h	4-dot inversion	5h	N/4-dot inversion ^{Note}	6h	N/8-dot inversion ^{Note}	7h	N/16-dot inversion ^{Note}	8h	N/32-dot inversion ^{Note}	9h	Zig-Zag inversion Type 1	Ah	Zig-Zag inversion Type 2	Bh	Zig-Zag inversion Type 3	Ch	Zig-Zag inversion Type 4	Others	Reserved	1 line	+	-	+	-	+	-	2 line	+	-	+	-	+	-	3 line	+	-	+	-	+	-	4 line	+	-	+	-	+	-	1 line	-	+	-	+	-	+	2 line	-	+	-	+	-	+	3 line	-	+	-	+	-	+	4 line	-	+	-	+	-	+	1 line	+	-	+	-	+	-	2 line	-	+	-	+	-	+	3 line	+	-	+	-	+	-	4 line	-	+	-	+	-	+	1 line	-	+	-	+	-	+	2 line	+	-	+	-	+	-	3 line	-	+	-	+	-	+	4 line	+	-	+	-	+	-	1 line	+	-	+	-	+	-	2 line	+	-	+	-	+	-	3 line	-	+	-	+	-	+	4 line	-	+	-	+	-	+	1 line	-	+	-	+	-	+	2 line	-	+	-	+	-	+	3 line	+	-	+	-	+	-	4 line	+	-	+	-	+	-
	DINV[3:0]	Inversion																																																																																																																																																																																																															
	0h	Column inversion																																																																																																																																																																																																															
	1h	1-dot inversion																																																																																																																																																																																																															
	2h	2-dot inversion																																																																																																																																																																																																															
	3h	3-dot inversion																																																																																																																																																																																																															
	4h	4-dot inversion																																																																																																																																																																																																															
	5h	N/4-dot inversion ^{Note}																																																																																																																																																																																																															
	6h	N/8-dot inversion ^{Note}																																																																																																																																																																																																															
	7h	N/16-dot inversion ^{Note}																																																																																																																																																																																																															
	8h	N/32-dot inversion ^{Note}																																																																																																																																																																																																															
	9h	Zig-Zag inversion Type 1																																																																																																																																																																																																															
	Ah	Zig-Zag inversion Type 2																																																																																																																																																																																																															
	Bh	Zig-Zag inversion Type 3																																																																																																																																																																																																															
	Ch	Zig-Zag inversion Type 4																																																																																																																																																																																																															
Others	Reserved																																																																																																																																																																																																																
1 line	+	-	+	-	+	-																																																																																																																																																																																																											
2 line	+	-	+	-	+	-																																																																																																																																																																																																											
3 line	+	-	+	-	+	-																																																																																																																																																																																																											
4 line	+	-	+	-	+	-																																																																																																																																																																																																											
1 line	-	+	-	+	-	+																																																																																																																																																																																																											
2 line	-	+	-	+	-	+																																																																																																																																																																																																											
3 line	-	+	-	+	-	+																																																																																																																																																																																																											
4 line	-	+	-	+	-	+																																																																																																																																																																																																											
1 line	+	-	+	-	+	-																																																																																																																																																																																																											
2 line	-	+	-	+	-	+																																																																																																																																																																																																											
3 line	+	-	+	-	+	-																																																																																																																																																																																																											
4 line	-	+	-	+	-	+																																																																																																																																																																																																											
1 line	-	+	-	+	-	+																																																																																																																																																																																																											
2 line	+	-	+	-	+	-																																																																																																																																																																																																											
3 line	-	+	-	+	-	+																																																																																																																																																																																																											
4 line	+	-	+	-	+	-																																																																																																																																																																																																											
1 line	+	-	+	-	+	-																																																																																																																																																																																																											
2 line	+	-	+	-	+	-																																																																																																																																																																																																											
3 line	-	+	-	+	-	+																																																																																																																																																																																																											
4 line	-	+	-	+	-	+																																																																																																																																																																																																											
1 line	-	+	-	+	-	+																																																																																																																																																																																																											
2 line	-	+	-	+	-	+																																																																																																																																																																																																											
3 line	+	-	+	-	+	-																																																																																																																																																																																																											
4 line	+	-	+	-	+	-																																																																																																																																																																																																											

	<p style="text-align: center;">3-Dot Inversion</p> <div style="display: flex; justify-content: space-around;"> <div style="text-align: center;"> <p>1st frame</p> <table border="1"> <tr><td>1 line</td><td>+</td><td>-</td><td>+</td><td>-</td><td>+</td><td>-</td></tr> <tr><td>2 line</td><td>+</td><td>-</td><td>+</td><td>-</td><td>+</td><td>-</td></tr> <tr><td>3 line</td><td>+</td><td>-</td><td>+</td><td>-</td><td>+</td><td>-</td></tr> <tr><td>4 line</td><td>-</td><td>+</td><td>-</td><td>+</td><td>-</td><td>+</td></tr> <tr><td>5 line</td><td>-</td><td>+</td><td>-</td><td>+</td><td>-</td><td>+</td></tr> <tr><td>6 line</td><td>-</td><td>+</td><td>-</td><td>+</td><td>-</td><td>+</td></tr> </table> </div> <div style="font-size: 2em;">→</div> <div style="text-align: center;"> <p>2nd frame</p> <table border="1"> <tr><td>1 line</td><td>-</td><td>+</td><td>-</td><td>+</td><td>-</td><td>+</td></tr> <tr><td>2 line</td><td>-</td><td>+</td><td>-</td><td>+</td><td>-</td><td>+</td></tr> <tr><td>3 line</td><td>-</td><td>+</td><td>-</td><td>+</td><td>-</td><td>+</td></tr> <tr><td>4 line</td><td>+</td><td>-</td><td>+</td><td>-</td><td>+</td><td>-</td></tr> <tr><td>5 line</td><td>+</td><td>-</td><td>+</td><td>-</td><td>+</td><td>-</td></tr> <tr><td>6 line</td><td>+</td><td>-</td><td>+</td><td>-</td><td>+</td><td>-</td></tr> </table> </div> </div> <p style="text-align: center;">4-Dot Inversion</p> <div style="display: flex; justify-content: space-around;"> <div style="text-align: center;"> <p>1st frame</p> <table border="1"> <tr><td>1 line</td><td>+</td><td>-</td><td>+</td><td>-</td><td>+</td><td>-</td></tr> <tr><td>2 line</td><td>+</td><td>-</td><td>+</td><td>-</td><td>+</td><td>-</td></tr> <tr><td>3 line</td><td>+</td><td>-</td><td>+</td><td>-</td><td>+</td><td>-</td></tr> <tr><td>4 line</td><td>+</td><td>-</td><td>+</td><td>-</td><td>+</td><td>-</td></tr> <tr><td>5 line</td><td>-</td><td>+</td><td>-</td><td>+</td><td>-</td><td>+</td></tr> <tr><td>6 line</td><td>-</td><td>+</td><td>-</td><td>+</td><td>-</td><td>+</td></tr> <tr><td>7 line</td><td>-</td><td>+</td><td>-</td><td>+</td><td>-</td><td>+</td></tr> <tr><td>8 line</td><td>-</td><td>+</td><td>-</td><td>+</td><td>-</td><td>+</td></tr> </table> </div> <div style="font-size: 2em;">→</div> <div style="text-align: center;"> <p>2nd frame</p> <table border="1"> <tr><td>1 line</td><td>-</td><td>+</td><td>-</td><td>+</td><td>-</td><td>+</td></tr> <tr><td>2 line</td><td>-</td><td>+</td><td>-</td><td>+</td><td>-</td><td>+</td></tr> <tr><td>3 line</td><td>-</td><td>+</td><td>-</td><td>+</td><td>-</td><td>+</td></tr> <tr><td>4 line</td><td>-</td><td>+</td><td>-</td><td>+</td><td>-</td><td>+</td></tr> <tr><td>5 line</td><td>+</td><td>-</td><td>+</td><td>-</td><td>+</td><td>-</td></tr> <tr><td>6 line</td><td>+</td><td>-</td><td>+</td><td>-</td><td>+</td><td>-</td></tr> <tr><td>7 line</td><td>+</td><td>-</td><td>+</td><td>-</td><td>+</td><td>-</td></tr> <tr><td>8 line</td><td>+</td><td>-</td><td>+</td><td>-</td><td>+</td><td>-</td></tr> </table> </div> </div>	1 line	+	-	+	-	+	-	2 line	+	-	+	-	+	-	3 line	+	-	+	-	+	-	4 line	-	+	-	+	-	+	5 line	-	+	-	+	-	+	6 line	-	+	-	+	-	+	1 line	-	+	-	+	-	+	2 line	-	+	-	+	-	+	3 line	-	+	-	+	-	+	4 line	+	-	+	-	+	-	5 line	+	-	+	-	+	-	6 line	+	-	+	-	+	-	1 line	+	-	+	-	+	-	2 line	+	-	+	-	+	-	3 line	+	-	+	-	+	-	4 line	+	-	+	-	+	-	5 line	-	+	-	+	-	+	6 line	-	+	-	+	-	+	7 line	-	+	-	+	-	+	8 line	-	+	-	+	-	+	1 line	-	+	-	+	-	+	2 line	-	+	-	+	-	+	3 line	-	+	-	+	-	+	4 line	-	+	-	+	-	+	5 line	+	-	+	-	+	-	6 line	+	-	+	-	+	-	7 line	+	-	+	-	+	-	8 line	+	-	+	-	+	-
1 line	+	-	+	-	+	-																																																																																																																																																																																															
2 line	+	-	+	-	+	-																																																																																																																																																																																															
3 line	+	-	+	-	+	-																																																																																																																																																																																															
4 line	-	+	-	+	-	+																																																																																																																																																																																															
5 line	-	+	-	+	-	+																																																																																																																																																																																															
6 line	-	+	-	+	-	+																																																																																																																																																																																															
1 line	-	+	-	+	-	+																																																																																																																																																																																															
2 line	-	+	-	+	-	+																																																																																																																																																																																															
3 line	-	+	-	+	-	+																																																																																																																																																																																															
4 line	+	-	+	-	+	-																																																																																																																																																																																															
5 line	+	-	+	-	+	-																																																																																																																																																																																															
6 line	+	-	+	-	+	-																																																																																																																																																																																															
1 line	+	-	+	-	+	-																																																																																																																																																																																															
2 line	+	-	+	-	+	-																																																																																																																																																																																															
3 line	+	-	+	-	+	-																																																																																																																																																																																															
4 line	+	-	+	-	+	-																																																																																																																																																																																															
5 line	-	+	-	+	-	+																																																																																																																																																																																															
6 line	-	+	-	+	-	+																																																																																																																																																																																															
7 line	-	+	-	+	-	+																																																																																																																																																																																															
8 line	-	+	-	+	-	+																																																																																																																																																																																															
1 line	-	+	-	+	-	+																																																																																																																																																																																															
2 line	-	+	-	+	-	+																																																																																																																																																																																															
3 line	-	+	-	+	-	+																																																																																																																																																																																															
4 line	-	+	-	+	-	+																																																																																																																																																																																															
5 line	+	-	+	-	+	-																																																																																																																																																																																															
6 line	+	-	+	-	+	-																																																																																																																																																																																															
7 line	+	-	+	-	+	-																																																																																																																																																																																															
8 line	+	-	+	-	+	-																																																																																																																																																																																															
Restriction	None																																																																																																																																																																																																				
Register Availability	<table border="1" style="margin-left: auto; margin-right: auto;"> <thead> <tr> <th>Status</th> <th>Availability</th> </tr> </thead> <tbody> <tr> <td>Normal Mode On, Idle Mode Off, Sleep Out</td> <td>Yes</td> </tr> <tr> <td>Normal Mode On, Idle Mode On, Sleep Out</td> <td>Yes</td> </tr> <tr> <td>Sleep In</td> <td>Yes</td> </tr> </tbody> </table>	Status	Availability	Normal Mode On, Idle Mode Off, Sleep Out	Yes	Normal Mode On, Idle Mode On, Sleep Out	Yes	Sleep In	Yes																																																																																																																																																																																												
Status	Availability																																																																																																																																																																																																				
Normal Mode On, Idle Mode Off, Sleep Out	Yes																																																																																																																																																																																																				
Normal Mode On, Idle Mode On, Sleep Out	Yes																																																																																																																																																																																																				
Sleep In	Yes																																																																																																																																																																																																				
Default	<table border="1" style="margin-left: auto; margin-right: auto;"> <thead> <tr> <th>Status</th> <th>Default Value</th> </tr> </thead> <tbody> <tr> <td>Power On Sequence</td> <td>00h</td> </tr> <tr> <td>S/W Reset</td> <td>00h</td> </tr> <tr> <td>H/W Reset</td> <td>00h</td> </tr> </tbody> </table>	Status	Default Value	Power On Sequence	00h	S/W Reset	00h	H/W Reset	00h																																																																																																																																																																																												
Status	Default Value																																																																																																																																																																																																				
Power On Sequence	00h																																																																																																																																																																																																				
S/W Reset	00h																																																																																																																																																																																																				
H/W Reset	00h																																																																																																																																																																																																				

5.4.7. Dithering Enable (34h)

Command Page			Page 1																
Address	Parameter	W/R	D7	D6	D5	D4	D3	D2	D1	D0	Default								
34h	1st	W/R	0	0	0	0	0	0	0	DITH_EN	00h								
Description	DITH_EN: 0 : dithering function disable 1 : dithering function enable																		
Restriction	None																		
Register Availability	<table border="1"> <thead> <tr> <th>Status</th> <th>Availability</th> </tr> </thead> <tbody> <tr> <td>Normal Mode On, Idle Mode Off, Sleep Out</td> <td>Yes</td> </tr> <tr> <td>Normal Mode On, Idle Mode On, Sleep Out</td> <td>Yes</td> </tr> <tr> <td>Sleep In</td> <td>Yes</td> </tr> </tbody> </table>											Status	Availability	Normal Mode On, Idle Mode Off, Sleep Out	Yes	Normal Mode On, Idle Mode On, Sleep Out	Yes	Sleep In	Yes
Status	Availability																		
Normal Mode On, Idle Mode Off, Sleep Out	Yes																		
Normal Mode On, Idle Mode On, Sleep Out	Yes																		
Sleep In	Yes																		
Default	<table border="1"> <thead> <tr> <th>Status</th> <th>Default Value</th> </tr> </thead> <tbody> <tr> <td>Power On Sequence</td> <td>00h</td> </tr> <tr> <td>S/W Reset</td> <td>00h</td> </tr> <tr> <td>H/W Reset</td> <td>00h</td> </tr> </tbody> </table>											Status	Default Value	Power On Sequence	00h	S/W Reset	00h	H/W Reset	00h
Status	Default Value																		
Power On Sequence	00h																		
S/W Reset	00h																		
H/W Reset	00h																		

5.4.8. Pump Clock Adjustment (40h~43h)

Command Page		Page 1																																																					
Address	Parameter	W/R	D7	D6	D5	D4	D3	D2	D1	D0	Default																																												
40h	1st	W/R	0	EXT_CPCK_SEL[1:0]		1	0	0	VCL_CLK_K_EN	VGHL_CLK_LK_EN	33h																																												
41h	1st	W/R	0	VCL_CLK_SELA[2:0]			0	VCL_CLK_SELB[2:0]			33h																																												
42h	1st	W/R	0	VGHL_CLK_SELA[2:0]			0	VGHL_CLK_SELB[2:0]			44h																																												
43h	1st	W/R	0	4002_RATIO_FREQA[2:0]			0	4002_RATIO_FREQB[2:0]			55h																																												
Description	<p>EXT_CPCK_SEL[1:0]: Pumping clock control signals selection to external control IC (ILI4003). Set the register before Sleep Out(R11h), when external pumping control be used.</p> <table border="1" style="margin-left: 40px;"> <thead> <tr> <th>EXT_CPCK_SEL[1:0]</th> <th>EXTP & EXTN Output</th> </tr> </thead> <tbody> <tr> <td>0h</td> <td>Output x 1.5 waveform</td> </tr> <tr> <td>1h</td> <td>Output x 2 waveform</td> </tr> <tr> <td>2h</td> <td>Output x 3 waveform</td> </tr> <tr> <td>3h</td> <td>Output Low (power down)</td> </tr> </tbody> </table> <p>VCL_CLK_EN: Enable the pumping cycle of step-up circuit of VCL.</p> <p>VGHL_CLK_EN: Enable the pumping cycle of step-up circuit of VGH and VGL.</p> <p>VCL_CLK_SELA[2:0]: Selects the pumping cycle of step-up circuit of VCL in the Normal Mode.</p> <p>VCL_CLK_SELB[2:0]: Selects the pumping cycle of step-up circuit of VCL in the Idle Mode.</p> <p>VGHL_CLK_SELA[2:0]: Selects the pumping cycle of step-up circuit of VGH and VGL in the Normal Mode.</p> <p>VGHL_CLK_SELB[2:0]: Selects the pumping cycle of step-up circuit of VGH and VGL in the Idle Mode.</p> <p>4002_RATIO_FREQA[2:0]: Selects the pumping cycle of step-up circuit of external control IC (ILI4003) in the Normal Mode.</p> <p>4002_RATIO_FREQB[2:0]: Selects the pumping cycle of step-up circuit of external control IC (ILI4003) in the Idle Mode.</p> <p>Select the optimal step-up factor for the operating voltage. To reduce power consumption, set a smaller factor.</p> <table border="1" style="margin-left: 40px;"> <thead> <tr> <th>VGHL_CLK_SELA[2:0], VGHL_CLK_SELB[2:0] VCL_CLK_SELA[2:0], VCL_CLK_SELB[2:0]</th> <th>Pumping cycle</th> </tr> </thead> <tbody> <tr> <td>0h</td> <td>16H</td> </tr> <tr> <td>1h</td> <td>8H</td> </tr> <tr> <td>2h</td> <td>4H</td> </tr> <tr> <td>3h</td> <td>2H</td> </tr> <tr> <td>4h</td> <td>1H</td> </tr> <tr> <td>5h</td> <td>1/2H</td> </tr> <tr> <td>Others</td> <td>Reserved</td> </tr> </tbody> </table> <table border="1" style="margin-left: 40px;"> <thead> <tr> <th>4002_RATIO_FREQA[2:0], 4002_RATIO_FREQB[2:0]</th> <th>Pumping cycle</th> </tr> </thead> <tbody> <tr> <td>0h</td> <td>16H</td> </tr> <tr> <td>1h</td> <td>8H</td> </tr> <tr> <td>2h</td> <td>4H</td> </tr> <tr> <td>3h</td> <td>2H</td> </tr> <tr> <td>4h</td> <td>1H</td> </tr> <tr> <td>5h</td> <td>1/2H</td> </tr> <tr> <td>6h</td> <td>1/4H</td> </tr> <tr> <td>7h</td> <td>1/8H</td> </tr> </tbody> </table>											EXT_CPCK_SEL[1:0]	EXTP & EXTN Output	0h	Output x 1.5 waveform	1h	Output x 2 waveform	2h	Output x 3 waveform	3h	Output Low (power down)	VGHL_CLK_SELA[2:0], VGHL_CLK_SELB[2:0] VCL_CLK_SELA[2:0], VCL_CLK_SELB[2:0]	Pumping cycle	0h	16H	1h	8H	2h	4H	3h	2H	4h	1H	5h	1/2H	Others	Reserved	4002_RATIO_FREQA[2:0], 4002_RATIO_FREQB[2:0]	Pumping cycle	0h	16H	1h	8H	2h	4H	3h	2H	4h	1H	5h	1/2H	6h	1/4H	7h	1/8H
	EXT_CPCK_SEL[1:0]	EXTP & EXTN Output																																																					
	0h	Output x 1.5 waveform																																																					
	1h	Output x 2 waveform																																																					
	2h	Output x 3 waveform																																																					
	3h	Output Low (power down)																																																					
	VGHL_CLK_SELA[2:0], VGHL_CLK_SELB[2:0] VCL_CLK_SELA[2:0], VCL_CLK_SELB[2:0]	Pumping cycle																																																					
	0h	16H																																																					
	1h	8H																																																					
	2h	4H																																																					
3h	2H																																																						
4h	1H																																																						
5h	1/2H																																																						
Others	Reserved																																																						
4002_RATIO_FREQA[2:0], 4002_RATIO_FREQB[2:0]	Pumping cycle																																																						
0h	16H																																																						
1h	8H																																																						
2h	4H																																																						
3h	2H																																																						
4h	1H																																																						
5h	1/2H																																																						
6h	1/4H																																																						
7h	1/8H																																																						
Restriction	None																																																						

<p>Register Availability</p>	<table border="1"> <thead> <tr> <th data-bbox="608 241 1046 275">Status</th> <th data-bbox="1046 241 1286 275">Availability</th> </tr> </thead> <tbody> <tr> <td data-bbox="608 275 1046 309">Normal Mode On, Idle Mode Off, Sleep Out</td> <td data-bbox="1046 275 1286 309">Yes</td> </tr> <tr> <td data-bbox="608 309 1046 342">Normal Mode On, Idle Mode On, Sleep Out</td> <td data-bbox="1046 309 1286 342">Yes</td> </tr> <tr> <td data-bbox="608 342 1046 376">Sleep In</td> <td data-bbox="1046 342 1286 376">Yes</td> </tr> </tbody> </table>	Status	Availability	Normal Mode On, Idle Mode Off, Sleep Out	Yes	Normal Mode On, Idle Mode On, Sleep Out	Yes	Sleep In	Yes
Status	Availability								
Normal Mode On, Idle Mode Off, Sleep Out	Yes								
Normal Mode On, Idle Mode On, Sleep Out	Yes								
Sleep In	Yes								
<p>Default</p>	<table border="1"> <thead> <tr> <th data-bbox="608 445 860 479">Status</th> <th data-bbox="860 445 1283 479">Default Value</th> </tr> </thead> <tbody> <tr> <td data-bbox="608 479 860 512">Power On Sequence</td> <td data-bbox="860 479 1283 512">33h_33h_44h_55h</td> </tr> <tr> <td data-bbox="608 512 860 546">S/W Reset</td> <td data-bbox="860 512 1283 546">33h_33h_44h_55h</td> </tr> <tr> <td data-bbox="608 546 860 580">H/W Reset</td> <td data-bbox="860 546 1283 580">33h_33h_44h_55h</td> </tr> </tbody> </table>	Status	Default Value	Power On Sequence	33h_33h_44h_55h	S/W Reset	33h_33h_44h_55h	H/W Reset	33h_33h_44h_55h
Status	Default Value								
Power On Sequence	33h_33h_44h_55h								
S/W Reset	33h_33h_44h_55h								
H/W Reset	33h_33h_44h_55h								

5.4.9. Power Control 1 (50h~51h)

Command Page			Page 1																																																																																								
Address	Parameter	W/R	D7	D6	D5	D4	D3	D2	D1	D0	Default																																																																																
50h	1st	W/R	VREG1[7:0]									95h																																																																															
51h	1st	W/R	VREG2[7:0]									95h																																																																															
Description	<p>VREG1[7:0]: Set the VREG1OUT voltage for positive Gamma. (12mV/step)</p> <table border="1"> <thead> <tr> <th>VREG1[7:0]</th> <th>VREG1OUT voltage (V)</th> </tr> </thead> <tbody> <tr><td>42h</td><td>3.504</td></tr> <tr><td>43h</td><td>3.516</td></tr> <tr><td>44h</td><td>3.528</td></tr> <tr><td>45h</td><td>3.540</td></tr> <tr><td>46h</td><td>3.552</td></tr> <tr><td>47h</td><td>3.564</td></tr> <tr><td>:</td><td>:</td></tr> <tr><td>94h</td><td>4.488</td></tr> <tr><td>95h</td><td>4.500</td></tr> <tr><td>96h</td><td>4.512</td></tr> <tr><td>:</td><td>:</td></tr> <tr><td>E8h</td><td>5.496</td></tr> <tr><td>E9h</td><td>5.508</td></tr> <tr><td>EAh</td><td>5.520</td></tr> <tr><td>:</td><td>:</td></tr> <tr><td>EFh</td><td>5.580</td></tr> <tr><td>F0h</td><td>5.592</td></tr> <tr><td>F1h</td><td>5.604</td></tr> <tr><td>Other</td><td>Reserved</td></tr> </tbody> </table> <p>VREG2[7:0]: Set the VREG2OUT voltage for negative Gamma. (12mV/step)</p> <table border="1"> <thead> <tr> <th>VREG2[7:0]</th> <th>VREG2OUT voltage (V)</th> </tr> </thead> <tbody> <tr><td>42h</td><td>-3.564</td></tr> <tr><td>43h</td><td>-3.576</td></tr> <tr><td>44h</td><td>-3.588</td></tr> <tr><td>45h</td><td>-3.600</td></tr> <tr><td>46h</td><td>-3.612</td></tr> <tr><td>47h</td><td>-3.624</td></tr> <tr><td>:</td><td>:</td></tr> <tr><td>94h</td><td>-4.548</td></tr> <tr><td>95h</td><td>-4.560</td></tr> <tr><td>96h</td><td>-4.572</td></tr> <tr><td>:</td><td>:</td></tr> <tr><td>E8h</td><td>-5.556</td></tr> <tr><td>E9h</td><td>-5.568</td></tr> <tr><td>EAh</td><td>-5.580</td></tr> <tr><td>:</td><td>:</td></tr> <tr><td>EFh</td><td>-5.640</td></tr> <tr><td>F0h</td><td>-5.652</td></tr> <tr><td>F1h</td><td>-5.664</td></tr> <tr><td>Other</td><td>Reserved</td></tr> </tbody> </table>											VREG1[7:0]	VREG1OUT voltage (V)	42h	3.504	43h	3.516	44h	3.528	45h	3.540	46h	3.552	47h	3.564	:	:	94h	4.488	95h	4.500	96h	4.512	:	:	E8h	5.496	E9h	5.508	EAh	5.520	:	:	EFh	5.580	F0h	5.592	F1h	5.604	Other	Reserved	VREG2[7:0]	VREG2OUT voltage (V)	42h	-3.564	43h	-3.576	44h	-3.588	45h	-3.600	46h	-3.612	47h	-3.624	:	:	94h	-4.548	95h	-4.560	96h	-4.572	:	:	E8h	-5.556	E9h	-5.568	EAh	-5.580	:	:	EFh	-5.640	F0h	-5.652	F1h	-5.664	Other	Reserved
	VREG1[7:0]	VREG1OUT voltage (V)																																																																																									
42h	3.504																																																																																										
43h	3.516																																																																																										
44h	3.528																																																																																										
45h	3.540																																																																																										
46h	3.552																																																																																										
47h	3.564																																																																																										
:	:																																																																																										
94h	4.488																																																																																										
95h	4.500																																																																																										
96h	4.512																																																																																										
:	:																																																																																										
E8h	5.496																																																																																										
E9h	5.508																																																																																										
EAh	5.520																																																																																										
:	:																																																																																										
EFh	5.580																																																																																										
F0h	5.592																																																																																										
F1h	5.604																																																																																										
Other	Reserved																																																																																										
VREG2[7:0]	VREG2OUT voltage (V)																																																																																										
42h	-3.564																																																																																										
43h	-3.576																																																																																										
44h	-3.588																																																																																										
45h	-3.600																																																																																										
46h	-3.612																																																																																										
47h	-3.624																																																																																										
:	:																																																																																										
94h	-4.548																																																																																										
95h	-4.560																																																																																										
96h	-4.572																																																																																										
:	:																																																																																										
E8h	-5.556																																																																																										
E9h	-5.568																																																																																										
EAh	-5.580																																																																																										
:	:																																																																																										
EFh	-5.640																																																																																										
F0h	-5.652																																																																																										
F1h	-5.664																																																																																										
Other	Reserved																																																																																										
Restriction	None																																																																																										

<p>Register Availability</p>	<table border="1"> <thead> <tr> <th data-bbox="609 241 1050 277">Status</th> <th data-bbox="1050 241 1289 277">Availability</th> </tr> </thead> <tbody> <tr> <td data-bbox="609 277 1050 309">Normal Mode On, Idle Mode Off, Sleep Out</td> <td data-bbox="1050 277 1289 309">Yes</td> </tr> <tr> <td data-bbox="609 309 1050 340">Normal Mode On, Idle Mode On, Sleep Out</td> <td data-bbox="1050 309 1289 340">Yes</td> </tr> <tr> <td data-bbox="609 340 1050 371">Sleep In</td> <td data-bbox="1050 340 1289 371">Yes</td> </tr> </tbody> </table>	Status	Availability	Normal Mode On, Idle Mode Off, Sleep Out	Yes	Normal Mode On, Idle Mode On, Sleep Out	Yes	Sleep In	Yes
Status	Availability								
Normal Mode On, Idle Mode Off, Sleep Out	Yes								
Normal Mode On, Idle Mode On, Sleep Out	Yes								
Sleep In	Yes								
<p>Default</p>	<table border="1"> <thead> <tr> <th data-bbox="687 443 938 479">Status</th> <th data-bbox="938 443 1209 479">Default Value</th> </tr> </thead> <tbody> <tr> <td data-bbox="687 479 938 510">Power On Sequence</td> <td data-bbox="938 479 1209 510">95h_95h</td> </tr> <tr> <td data-bbox="687 510 938 542">S/W Reset</td> <td data-bbox="938 510 1209 542">95h_95h</td> </tr> <tr> <td data-bbox="687 542 938 573">H/W Reset</td> <td data-bbox="938 542 1209 573">95h_95h</td> </tr> </tbody> </table>	Status	Default Value	Power On Sequence	95h_95h	S/W Reset	95h_95h	H/W Reset	95h_95h
Status	Default Value								
Power On Sequence	95h_95h								
S/W Reset	95h_95h								
H/W Reset	95h_95h								

5.4.10. VCOM Control 1 (52h~56h)

Command Page			Page 1																																												
Address	Parameter	W/R	D7	D6	D5	D4	D3	D2	D1	D0	Default																																				
52h	1st	W/R	0	0	0	0	0	0	0	VCM1[8]	00h																																				
53h	1st	W/R	VCM1[7:0]									7Bh																																			
54h	1st	W/R	0	0	0	0	0	0	0	VCM2[8]	00h																																				
55h	1st	W/R	VCM2[7:0]									7Bh																																			
56h	1st	R	0	0	0	NVM2	0	0	0	NVM1	00h																																				
Description	<p>VCM1[8:0]: Set the VCOM level used for vertical forward scan (GS_PANEL= 1'b0), when NV memory isn't programmed. (12mV/step)</p> <p>VCM2[8:0]: Set the VCOM level used for vertical backward scan (GS_PANEL= 1'b1), when NV memory isn't programmed. (12mV/step)</p> <table border="1" style="margin-left: auto; margin-right: auto;"> <thead> <tr> <th>VCM1[8:0] VCM2[8:0]</th> <th>VCOM voltage (V)</th> </tr> </thead> <tbody> <tr><td>010h</td><td>-0.204</td></tr> <tr><td>011h</td><td>-0.216</td></tr> <tr><td>012h</td><td>-0.228</td></tr> <tr><td>013h</td><td>-0.24</td></tr> <tr><td>014h</td><td>-0.252</td></tr> <tr><td>015h</td><td>-0.264</td></tr> <tr><td>:</td><td>:</td></tr> <tr><td>07Ah</td><td>-1.476</td></tr> <tr><td>07Bh</td><td>-1.488</td></tr> <tr><td>07Ch</td><td>-1.5</td></tr> <tr><td>:</td><td>:</td></tr> <tr><td>149h</td><td>-3.96</td></tr> <tr><td>14Ah</td><td>-3.972</td></tr> <tr><td>14Bh</td><td>-3.984</td></tr> <tr><td>14Ch</td><td>-3.996</td></tr> <tr><td>14Dh</td><td>-4.008</td></tr> <tr><td>Others</td><td>Reserved</td></tr> </tbody> </table> <p><i>Note: VCOM ≥ VSN + 0.5V</i></p> <p>NVM1 : Selection of the VCM source setting used for vertical forward scan (GS_PANEL= 1'b0). When the NV memory is programmed, the NVM1 will be set as '1' automatically.</p> <p>0 : Register Page 1 R52h and R53h for VCM setting</p> <p>1 : Register Page 4 RC4h and RC5h for VCM setting</p> <p>NVM2 : Selection of the VCM source setting used for vertical backward scan (GS_PANEL= 1'b1). When the NV memory is programmed, the NVM2 will be set as '1' automatically.</p> <p>0 : Register 54h and 55h for VCM setting</p> <p>1 : Register Page 4 RC6h and RC7h for VCM setting</p>											VCM1[8:0] VCM2[8:0]	VCOM voltage (V)	010h	-0.204	011h	-0.216	012h	-0.228	013h	-0.24	014h	-0.252	015h	-0.264	:	:	07Ah	-1.476	07Bh	-1.488	07Ch	-1.5	:	:	149h	-3.96	14Ah	-3.972	14Bh	-3.984	14Ch	-3.996	14Dh	-4.008	Others	Reserved
	VCM1[8:0] VCM2[8:0]	VCOM voltage (V)																																													
	010h	-0.204																																													
	011h	-0.216																																													
	012h	-0.228																																													
	013h	-0.24																																													
	014h	-0.252																																													
	015h	-0.264																																													
	:	:																																													
	07Ah	-1.476																																													
	07Bh	-1.488																																													
	07Ch	-1.5																																													
	:	:																																													
	149h	-3.96																																													
	14Ah	-3.972																																													
14Bh	-3.984																																														
14Ch	-3.996																																														
14Dh	-4.008																																														
Others	Reserved																																														
Restriction	None																																														
Register Availability	<table border="1" style="margin-left: auto; margin-right: auto;"> <thead> <tr> <th>Status</th> <th>Availability</th> </tr> </thead> <tbody> <tr> <td>Normal Mode On, Idle Mode Off, Sleep Out</td> <td>Yes</td> </tr> <tr> <td>Normal Mode On, Idle Mode On, Sleep Out</td> <td>Yes</td> </tr> <tr> <td>Sleep In</td> <td>Yes</td> </tr> </tbody> </table>											Status	Availability	Normal Mode On, Idle Mode Off, Sleep Out	Yes	Normal Mode On, Idle Mode On, Sleep Out	Yes	Sleep In	Yes																												
Status	Availability																																														
Normal Mode On, Idle Mode Off, Sleep Out	Yes																																														
Normal Mode On, Idle Mode On, Sleep Out	Yes																																														
Sleep In	Yes																																														

Default	

Status	Default Value
Power On Sequence	00h_7Bh_00h_7Bh_00h
S/W Reset	00h_7Bh_00h_7Bh_00h
H/W Reset	00h_7Bh_00h_7Bh_00h

5.4.11. Entry Mode Set (58h)

Command Page			Page 1																
Address	Parameter	W/R	D7	D6	D5	D4	D3	D2	D1	D0	Default								
58h	1st	W/R	LVD_EN	0	0	0	0	0	0	0	00h								
Description	LVD_EN: Low voltage detection control.																		
	<table border="1"> <thead> <tr> <th>LVD</th> <th>Low voltage detection</th> </tr> </thead> <tbody> <tr> <td>0</td> <td>Enable</td> </tr> <tr> <td>1</td> <td>Disable</td> </tr> </tbody> </table>											LVD	Low voltage detection	0	Enable	1	Disable		
LVD	Low voltage detection																		
0	Enable																		
1	Disable																		
Restriction																			
Register Availability	<table border="1"> <thead> <tr> <th>Status</th> <th>Availability</th> </tr> </thead> <tbody> <tr> <td>Normal Mode On, Idle Mode Off, Sleep Out</td> <td>Yes</td> </tr> <tr> <td>Normal Mode On, Idle Mode On, Sleep Out</td> <td>Yes</td> </tr> <tr> <td>Sleep In</td> <td>Yes</td> </tr> </tbody> </table>											Status	Availability	Normal Mode On, Idle Mode Off, Sleep Out	Yes	Normal Mode On, Idle Mode On, Sleep Out	Yes	Sleep In	Yes
Status	Availability																		
Normal Mode On, Idle Mode Off, Sleep Out	Yes																		
Normal Mode On, Idle Mode On, Sleep Out	Yes																		
Sleep In	Yes																		
Default	<table border="1"> <thead> <tr> <th>Status</th> <th>Default Value</th> </tr> </thead> <tbody> <tr> <td>Power On Sequence</td> <td>00h</td> </tr> <tr> <td>S/W Reset</td> <td>00h</td> </tr> <tr> <td>H/W Reset</td> <td>00h</td> </tr> </tbody> </table>											Status	Default Value	Power On Sequence	00h	S/W Reset	00h	H/W Reset	00h
Status	Default Value																		
Power On Sequence	00h																		
S/W Reset	00h																		
H/W Reset	00h																		

5.4.12. Source Timing Adjust (60h~63h)

Command Page			Page 1																
Address	Parameter	W/R	D7	D6	D5	D4	D3	D2	D1	D0	Default								
60h	1st	W/R	0	0	SDT[5:0]						14h								
61h	1st	W/R	0	0	CRT[5:0]						00h								
62h	1st	W/R	0	0	EQT[5:0]						19h								
63h	1st	W/R	0	0	PCT[5:0]						10h								
Description	<p>SDT[5:0]: Source SD timing adjustment (time scale: internal T_{OP_CLK}). The timing can be adjusted 0 to 63 time scales.</p> <p>CRT[5:0]: Source CR timing adjustment (time scale: internal T_{OP_CLK}). The timing can be adjusted 0 to 63 time scales.</p> <p>EQT[5:0]: Source EQ timing adjustment (time scale: internal T_{OP_CLK}). The timing can be adjusted 8 to 71 time scales.</p> <p>PCT[5:0]: Source PC timing adjustment (time scale: internal T_{OP_CLK}). The timing can be adjusted 0 to 63 time scales.</p> <p>Note: T_{OP_CLK}: 62.5ns</p>																		
	Restriction	None																	
Register Availability	<table border="1"> <thead> <tr> <th>Status</th> <th>Availability</th> </tr> </thead> <tbody> <tr> <td>Normal Mode On, Idle Mode Off, Sleep Out</td> <td>Yes</td> </tr> <tr> <td>Normal Mode On, Idle Mode On, Sleep Out</td> <td>Yes</td> </tr> <tr> <td>Sleep In</td> <td>Yes</td> </tr> </tbody> </table>											Status	Availability	Normal Mode On, Idle Mode Off, Sleep Out	Yes	Normal Mode On, Idle Mode On, Sleep Out	Yes	Sleep In	Yes
Status	Availability																		
Normal Mode On, Idle Mode Off, Sleep Out	Yes																		
Normal Mode On, Idle Mode On, Sleep Out	Yes																		
Sleep In	Yes																		
Default	<table border="1"> <thead> <tr> <th>Status</th> <th>Default Value</th> </tr> </thead> <tbody> <tr> <td>Power On Sequence</td> <td>14h_00h_19h_10h</td> </tr> <tr> <td>S/W Reset</td> <td>14h_00h_19h_10h</td> </tr> <tr> <td>H/W Reset</td> <td>14h_00h_19h_10h</td> </tr> </tbody> </table>											Status	Default Value	Power On Sequence	14h_00h_19h_10h	S/W Reset	14h_00h_19h_10h	H/W Reset	14h_00h_19h_10h
Status	Default Value																		
Power On Sequence	14h_00h_19h_10h																		
S/W Reset	14h_00h_19h_10h																		
H/W Reset	14h_00h_19h_10h																		

5.4.13. Positive Gamma Correction (A0h~B3h)

Command Page			Page 1																
Address	Parameter	W/R	D7	D6	D5	D4	D3	D2	D1	D0	Default								
A0h	1st	W/R	0	0	VP0[5:0]						00h								
A1h	1st	W/R	0	VP4[6:0]						0Dh									
A2h	1st	W/R	0	VP8[6:0]						1Dh									
A3h	1st	W/R	0	0	VP12[5:0]						11h								
A4h	1st	W/R	0	0	VP16[5:0]						0Ch								
A5h	1st	W/R	0	VP24[6:0]						23h									
A6h	1st	W/R	0	0	VP36[5:0]						17h								
A7h	1st	W/R	0	0	VP52[5:0]						1Ch								
A8h	1st	W/R	VP80[7:0]						82h										
A9h	1st	W/R	0	0	VP111[5:0]						21h								
AAh	1st	W/R	0	0	VP144[5:0]						2Ah								
ABh	1st	W/R	VP175[7:0]						6Bh										
ACh	1st	W/R	0	0	VP203[5:0]						19h								
ADh	1st	W/R	0	0	VP219[5:0]						14h								
A Eh	1st	W/R	0	VP231[6:0]						45h									
AFh	1st	W/R	0	0	VP239[5:0]						1Dh								
B0h	1st	W/R	0	0	VP243[5:0]						23h								
B1h	1st	W/R	0	VP247[6:0]						52h									
B2h	1st	W/R	0	VP251[6:0]						63h									
B3h	1st	W/R	0	0	VP255[5:0]						39h								
Description		Set the gray scale voltage to adjust the Gamma characteristics of the TFT panel.																	
Restriction		None																	
Register Availability		<table border="1"> <thead> <tr> <th>Status</th> <th>Availability</th> </tr> </thead> <tbody> <tr> <td>Normal Mode On, Idle Mode Off, Sleep Out</td> <td>Yes</td> </tr> <tr> <td>Normal Mode On, Idle Mode On, Sleep Out</td> <td>Yes</td> </tr> <tr> <td>Sleep In</td> <td>Yes</td> </tr> </tbody> </table>										Status	Availability	Normal Mode On, Idle Mode Off, Sleep Out	Yes	Normal Mode On, Idle Mode On, Sleep Out	Yes	Sleep In	Yes
Status	Availability																		
Normal Mode On, Idle Mode Off, Sleep Out	Yes																		
Normal Mode On, Idle Mode On, Sleep Out	Yes																		
Sleep In	Yes																		
Default		<table border="1"> <thead> <tr> <th>Status</th> <th>Default Value</th> </tr> </thead> <tbody> <tr> <td>Power On Sequence</td> <td>00h_0Dh_1Dh_11h_0Ch_23h_17h_1Ch_82h_21h_2Ah_6Bh_19h_14h_45h_1Dh_23h_52h_63h_39h</td> </tr> <tr> <td>S/W Reset</td> <td>00h_0Dh_1Dh_11h_0Ch_23h_17h_1Ch_82h_21h_2Ah_6Bh_19h_14h_45h_1Dh_23h_52h_63h_39h</td> </tr> <tr> <td>H/W Reset</td> <td>00h_0Dh_1Dh_11h_0Ch_23h_17h_1Ch_82h_21h_2Ah_6Bh_19h_14h_45h_1Dh_23h_52h_63h_39h</td> </tr> </tbody> </table>										Status	Default Value	Power On Sequence	00h_0Dh_1Dh_11h_0Ch_23h_17h_1Ch_82h_21h_2Ah_6Bh_19h_14h_45h_1Dh_23h_52h_63h_39h	S/W Reset	00h_0Dh_1Dh_11h_0Ch_23h_17h_1Ch_82h_21h_2Ah_6Bh_19h_14h_45h_1Dh_23h_52h_63h_39h	H/W Reset	00h_0Dh_1Dh_11h_0Ch_23h_17h_1Ch_82h_21h_2Ah_6Bh_19h_14h_45h_1Dh_23h_52h_63h_39h
Status	Default Value																		
Power On Sequence	00h_0Dh_1Dh_11h_0Ch_23h_17h_1Ch_82h_21h_2Ah_6Bh_19h_14h_45h_1Dh_23h_52h_63h_39h																		
S/W Reset	00h_0Dh_1Dh_11h_0Ch_23h_17h_1Ch_82h_21h_2Ah_6Bh_19h_14h_45h_1Dh_23h_52h_63h_39h																		
H/W Reset	00h_0Dh_1Dh_11h_0Ch_23h_17h_1Ch_82h_21h_2Ah_6Bh_19h_14h_45h_1Dh_23h_52h_63h_39h																		

5.4.14. Pad Control (B6h~B7h)

Command Page			Page 1																																																																																																							
Address	Parameter	W/R	D7	D6	D5	D4	D3	D2	D1	D0	Default																																																																																															
B6h	1st	W/R	IM_SW_EN	IM_SW[2:0]			RS_SW_EN	0	RS_SW[1:0]		00h																																																																																															
B7h	1st	W/R	0	0	0	0	0	0	LANSEL_SW_EN	LANSEL_SW	00h																																																																																															
Description	<p>IM_SW_EN: Enable/Disable the lane sequence and polarity from internal command setting. The external hardware pin IM[2:0] has no effect when IM_SW_EN is "1".</p> <p>IM_SW[2:0]: Set the configuration of lane sequence and polarity. (The bottom table is an example for MIPI 4 lane setting)</p> <table border="1" style="margin-left: 40px;"> <thead> <tr> <th colspan="3">Internal Pad Control</th> <th colspan="5">Configuration of MIPI Lane</th> </tr> <tr> <th>IM_SW2</th> <th>IM_SW1</th> <th>IM_SW0</th> <th>D0P/N Pin</th> <th>D1P/N Pin</th> <th>CLKP/N Pin</th> <th>D2P/N Pin</th> <th>D3P/N Pin</th> </tr> </thead> <tbody> <tr><td>0</td><td>0</td><td>0</td><td>D3P/N</td><td>D2P/N</td><td>CLKP/N</td><td>D1P/N</td><td>D0P/N</td></tr> <tr><td>0</td><td>0</td><td>1</td><td>D3N/P</td><td>D2N/P</td><td>CLKN/P</td><td>D1N/P</td><td>D0N/P</td></tr> <tr><td>0</td><td>1</td><td>0</td><td>D0P/N</td><td>D1P/N</td><td>CLKP/N</td><td>D2P/N</td><td>D3P/N</td></tr> <tr><td>0</td><td>1</td><td>1</td><td>D0N/P</td><td>D1N/P</td><td>CLKN/P</td><td>D2N/P</td><td>D3N/P</td></tr> <tr><td>1</td><td>0</td><td>0</td><td>D3P/N</td><td>D0P/N</td><td>CLKP/N</td><td>D1P/N</td><td>D2P/N</td></tr> <tr><td>1</td><td>0</td><td>1</td><td>D3N/P</td><td>D0N/P</td><td>CLKN/P</td><td>D1N/P</td><td>D2N/P</td></tr> <tr><td>1</td><td>1</td><td>0</td><td>D2P/N</td><td>D1P/N</td><td>CLKP/N</td><td>D0P/N</td><td>D3P/N</td></tr> <tr><td>1</td><td>1</td><td>1</td><td>D2N/P</td><td>D1N/P</td><td>CLKN/P</td><td>D0N/P</td><td>D3N/P</td></tr> </tbody> </table> <p>RS_SW_EN: Enable/Disable the resolution from internal command setting. The external hardware pin RS[1:0] has no effect when RS_SW_EN is "1".</p> <p>RS_SW[1:0]: Set the resolution.</p> <table border="1" style="margin-left: 40px;"> <thead> <tr> <th>RS_SW1</th> <th>RS_SW0</th> <th>Resolution</th> </tr> </thead> <tbody> <tr><td>0</td><td>0</td><td>800 (RGB) x (480 + (4 x NL)) gate line</td></tr> <tr><td>0</td><td>1</td><td>768 (RGB) x (480 + (4 x NL)) gate line</td></tr> <tr><td>1</td><td>0</td><td>720 (RGB) x (480 + (4 x NL)) gate line</td></tr> <tr><td>1</td><td>1</td><td>Reserved</td></tr> </tbody> </table> <p>LANSEL_SW_EN: Enable/Disable the lane number from internal command setting. The external hardware pin LANSEL has no effect when LANSEL_SW_EN is "1".</p> <p>LANSEL_SW: Set the lane number. LANSEL_SW="1", MIPI DSI is 2 Lane mode LANSEL_SW="0", MIPI DSI is 3 or 4 Lane mode</p> <p><i>Note: Please reference "Table 2: DSI Interface Lane Mode Selection"</i></p>											Internal Pad Control			Configuration of MIPI Lane					IM_SW2	IM_SW1	IM_SW0	D0P/N Pin	D1P/N Pin	CLKP/N Pin	D2P/N Pin	D3P/N Pin	0	0	0	D3P/N	D2P/N	CLKP/N	D1P/N	D0P/N	0	0	1	D3N/P	D2N/P	CLKN/P	D1N/P	D0N/P	0	1	0	D0P/N	D1P/N	CLKP/N	D2P/N	D3P/N	0	1	1	D0N/P	D1N/P	CLKN/P	D2N/P	D3N/P	1	0	0	D3P/N	D0P/N	CLKP/N	D1P/N	D2P/N	1	0	1	D3N/P	D0N/P	CLKN/P	D1N/P	D2N/P	1	1	0	D2P/N	D1P/N	CLKP/N	D0P/N	D3P/N	1	1	1	D2N/P	D1N/P	CLKN/P	D0N/P	D3N/P	RS_SW1	RS_SW0	Resolution	0	0	800 (RGB) x (480 + (4 x NL)) gate line	0	1	768 (RGB) x (480 + (4 x NL)) gate line	1	0	720 (RGB) x (480 + (4 x NL)) gate line	1	1	Reserved
	Internal Pad Control			Configuration of MIPI Lane																																																																																																						
	IM_SW2	IM_SW1	IM_SW0	D0P/N Pin	D1P/N Pin	CLKP/N Pin	D2P/N Pin	D3P/N Pin																																																																																																		
	0	0	0	D3P/N	D2P/N	CLKP/N	D1P/N	D0P/N																																																																																																		
	0	0	1	D3N/P	D2N/P	CLKN/P	D1N/P	D0N/P																																																																																																		
	0	1	0	D0P/N	D1P/N	CLKP/N	D2P/N	D3P/N																																																																																																		
	0	1	1	D0N/P	D1N/P	CLKN/P	D2N/P	D3N/P																																																																																																		
	1	0	0	D3P/N	D0P/N	CLKP/N	D1P/N	D2P/N																																																																																																		
	1	0	1	D3N/P	D0N/P	CLKN/P	D1N/P	D2N/P																																																																																																		
	1	1	0	D2P/N	D1P/N	CLKP/N	D0P/N	D3P/N																																																																																																		
1	1	1	D2N/P	D1N/P	CLKN/P	D0N/P	D3N/P																																																																																																			
RS_SW1	RS_SW0	Resolution																																																																																																								
0	0	800 (RGB) x (480 + (4 x NL)) gate line																																																																																																								
0	1	768 (RGB) x (480 + (4 x NL)) gate line																																																																																																								
1	0	720 (RGB) x (480 + (4 x NL)) gate line																																																																																																								
1	1	Reserved																																																																																																								
Restriction																																																																																																										
Register Availability	<table border="1" style="margin-left: 40px;"> <thead> <tr> <th>Status</th> <th>Availability</th> </tr> </thead> <tbody> <tr><td>Normal Mode On, Idle Mode Off, Sleep Out</td><td>Yes</td></tr> <tr><td>Normal Mode On, Idle Mode On, Sleep Out</td><td>Yes</td></tr> <tr><td>Sleep In</td><td>Yes</td></tr> </tbody> </table>											Status	Availability	Normal Mode On, Idle Mode Off, Sleep Out	Yes	Normal Mode On, Idle Mode On, Sleep Out	Yes	Sleep In	Yes																																																																																							
Status	Availability																																																																																																									
Normal Mode On, Idle Mode Off, Sleep Out	Yes																																																																																																									
Normal Mode On, Idle Mode On, Sleep Out	Yes																																																																																																									
Sleep In	Yes																																																																																																									
Default	<table border="1" style="margin-left: 40px;"> <thead> <tr> <th>Status</th> <th>Default Value</th> </tr> </thead> <tbody> <tr><td>Power On Sequence</td><td>00h_00h</td></tr> <tr><td>S/W Reset</td><td>00h_00h</td></tr> <tr><td>H/W Reset</td><td>00h_00h</td></tr> </tbody> </table>											Status	Default Value	Power On Sequence	00h_00h	S/W Reset	00h_00h	H/W Reset	00h_00h																																																																																							
Status	Default Value																																																																																																									
Power On Sequence	00h_00h																																																																																																									
S/W Reset	00h_00h																																																																																																									
H/W Reset	00h_00h																																																																																																									

5.4.15. Negative Gamma Correction (C0h~D3h)

Command Page			Page 1																
Address	Parameter	W/R	D7	D6	D5	D4	D3	D2	D1	D0	Default								
C0h	1st	W/R	0	0	VN0[5:0]						00h								
C1h	1st	W/R	0	VN4[6:0]						0Dh									
C2h	1st	W/R	0	VN8[6:0]						1Dh									
C3h	1st	W/R	0	0	VN12[5:0]						11h								
C4h	1st	W/R	0	0	VN16[5:0]						0Ch								
C5h	1st	W/R	0	VN24[6:0]						23h									
C6h	1st	W/R	0	0	VN36[5:0]						17h								
C7h	1st	W/R	0	0	VN52[5:0]						1Ch								
C8h	1st	W/R	VN80[7:0]						82h										
C9h	1st	W/R	0	0	VN111[5:0]						21h								
CAh	1st	W/R	0	0	VN144[5:0]						2Ah								
CBh	1st	W/R	VN175[7:0]						6Bh										
CCh	1st	W/R	0	0	VN203[5:0]						19h								
CDh	1st	W/R	0	0	VN219[5:0]						14h								
CEh	1st	W/R	0	VN231[6:0]						45h									
CFh	1st	W/R	0	0	VN239[5:0]						1Dh								
D0h	1st	W/R	0	0	VN243[5:0]						23h								
D1h	1st	W/R	0	VN247[6:0]						52h									
D2h	1st	W/R	0	VN251[6:0]						63h									
D3h	1st	W/R	0	0	VN255[5:0]						39h								
Description		Set the gray scale voltage to adjust the Gamma characteristics of the TFT panel.																	
Restriction		None																	
Register Availability		<table border="1"> <thead> <tr> <th>Status</th> <th>Availability</th> </tr> </thead> <tbody> <tr> <td>Normal Mode On, Idle Mode Off, Sleep Out</td> <td>Yes</td> </tr> <tr> <td>Normal Mode On, Idle Mode On, Sleep Out</td> <td>Yes</td> </tr> <tr> <td>Sleep In</td> <td>Yes</td> </tr> </tbody> </table>										Status	Availability	Normal Mode On, Idle Mode Off, Sleep Out	Yes	Normal Mode On, Idle Mode On, Sleep Out	Yes	Sleep In	Yes
Status	Availability																		
Normal Mode On, Idle Mode Off, Sleep Out	Yes																		
Normal Mode On, Idle Mode On, Sleep Out	Yes																		
Sleep In	Yes																		
Default		<table border="1"> <thead> <tr> <th>Status</th> <th>Default Value</th> </tr> </thead> <tbody> <tr> <td>Power On Sequence</td> <td>00h_0Dh_1Dh_11h_0Ch_23h_17h_1Ch_82h_21h_2Ah_6Bh_19h_14h_45h_1Dh_23h_52h_63h_39h</td> </tr> <tr> <td>S/W Reset</td> <td>00h_0Dh_1Dh_11h_0Ch_23h_17h_1Ch_82h_21h_2Ah_6Bh_19h_14h_45h_1Dh_23h_52h_63h_39h</td> </tr> <tr> <td>H/W Reset</td> <td>00h_0Dh_1Dh_11h_0Ch_23h_17h_1Ch_82h_21h_2Ah_6Bh_19h_14h_45h_1Dh_23h_52h_63h_39h</td> </tr> </tbody> </table>										Status	Default Value	Power On Sequence	00h_0Dh_1Dh_11h_0Ch_23h_17h_1Ch_82h_21h_2Ah_6Bh_19h_14h_45h_1Dh_23h_52h_63h_39h	S/W Reset	00h_0Dh_1Dh_11h_0Ch_23h_17h_1Ch_82h_21h_2Ah_6Bh_19h_14h_45h_1Dh_23h_52h_63h_39h	H/W Reset	00h_0Dh_1Dh_11h_0Ch_23h_17h_1Ch_82h_21h_2Ah_6Bh_19h_14h_45h_1Dh_23h_52h_63h_39h
Status	Default Value																		
Power On Sequence	00h_0Dh_1Dh_11h_0Ch_23h_17h_1Ch_82h_21h_2Ah_6Bh_19h_14h_45h_1Dh_23h_52h_63h_39h																		
S/W Reset	00h_0Dh_1Dh_11h_0Ch_23h_17h_1Ch_82h_21h_2Ah_6Bh_19h_14h_45h_1Dh_23h_52h_63h_39h																		
H/W Reset	00h_0Dh_1Dh_11h_0Ch_23h_17h_1Ch_82h_21h_2Ah_6Bh_19h_14h_45h_1Dh_23h_52h_63h_39h																		

5.4.16. NV Memory Write (E0h~E2h)

Command Page			Page 1																															
Address	Parameter	W/R	D7	D6	D5	D4	D3	D2	D1	D0	Default																							
E0h	1st	W/R	PGM_DATA[7:0]									00h																						
E1h	1st	W/R	PGM_ADR[7:0]									00h																						
E2h	1st	W/R	PGM_ADR[15:8]									00h																						
Description	<p>This command is used to program or read the NV memory data.</p> <p>After a successful OTP operation, the information of PGM_DATA[7:0] will be programmed to the NV memory.</p> <p>PGM_DATA[7:0]: The programmed data.</p> <p>PGM_ADR[15:0]: Set the address of the NV memory for programming data. See chapter 15 “NV Memory Programming Flow”.</p>																																	
	<table border="1"> <thead> <tr> <th>PGM_ADR[15:0]</th> <th>Programming data</th> </tr> </thead> <tbody> <tr><td>1h</td><td>ID1</td></tr> <tr><td>2h</td><td>ID2</td></tr> <tr><td>3h</td><td>ID3</td></tr> <tr><td>4h</td><td>VCM1[8]</td></tr> <tr><td>5h</td><td>VCM1[7:0]</td></tr> <tr><td>6h</td><td>VCM2[8]</td></tr> <tr><td>7h</td><td>VCM2[7:0]</td></tr> <tr><td>8h</td><td>VREG1[7:0]</td></tr> <tr><td>9h</td><td>VREG2[7:0]</td></tr> <tr><td>68h~7Bh</td><td>REGAM0_P~ REGAM255_P</td></tr> <tr><td>7Ch~8Fh</td><td>REGAM0_N~ REGAM255_N</td></tr> </tbody> </table>											PGM_ADR[15:0]	Programming data	1h	ID1	2h	ID2	3h	ID3	4h	VCM1[8]	5h	VCM1[7:0]	6h	VCM2[8]	7h	VCM2[7:0]	8h	VREG1[7:0]	9h	VREG2[7:0]	68h~7Bh	REGAM0_P~ REGAM255_P	7Ch~8Fh
PGM_ADR[15:0]	Programming data																																	
1h	ID1																																	
2h	ID2																																	
3h	ID3																																	
4h	VCM1[8]																																	
5h	VCM1[7:0]																																	
6h	VCM2[8]																																	
7h	VCM2[7:0]																																	
8h	VREG1[7:0]																																	
9h	VREG2[7:0]																																	
68h~7Bh	REGAM0_P~ REGAM255_P																																	
7Ch~8Fh	REGAM0_N~ REGAM255_N																																	
Restriction	None																																	
Register Availability	<table border="1"> <thead> <tr> <th>Status</th> <th>Availability</th> </tr> </thead> <tbody> <tr><td>Normal Mode On, Idle Mode Off, Sleep Out</td><td>Yes</td></tr> <tr><td>Normal Mode On, Idle Mode On, Sleep Out</td><td>Yes</td></tr> <tr><td>Sleep In</td><td>Yes</td></tr> </tbody> </table>											Status	Availability	Normal Mode On, Idle Mode Off, Sleep Out	Yes	Normal Mode On, Idle Mode On, Sleep Out	Yes	Sleep In	Yes															
Status	Availability																																	
Normal Mode On, Idle Mode Off, Sleep Out	Yes																																	
Normal Mode On, Idle Mode On, Sleep Out	Yes																																	
Sleep In	Yes																																	
Default	<table border="1"> <thead> <tr> <th>Status</th> <th>Default Value</th> </tr> </thead> <tbody> <tr><td>Power On Sequence</td><td>00h_00h_00h</td></tr> <tr><td>S/W Reset</td><td>00h_00h_00h</td></tr> <tr><td>H/W Reset</td><td>00h_00h_00h</td></tr> </tbody> </table>											Status	Default Value	Power On Sequence	00h_00h_00h	S/W Reset	00h_00h_00h	H/W Reset	00h_00h_00h															
Status	Default Value																																	
Power On Sequence	00h_00h_00h																																	
S/W Reset	00h_00h_00h																																	
H/W Reset	00h_00h_00h																																	

5.4.17. NV Memory Protection Key (E3h~E5h)

Command Page			Page 1																
Address	Parameter	W/R	D7	D6	D5	D4	D3	D2	D1	D0	Default								
E3h	1st	W/R	KEY[23:16]									00h							
E4h	1st	W/R	KEY[15:8]									00h							
E5h	1st	W/R	KEY[7:0]									00h							
Description	<p>KEY[23:0]: NV memory programming protection key. Write an OTP data to PGM_DATA[7:0], this KEY[23:0] must set 0x55AA66h to enable OTP programming. If the KEY[23:0] is not 0x55AA66h, the NV Memory program will be aborted.</p>																		
Restriction	None																		
Register Availability	<table border="1"> <thead> <tr> <th>Status</th> <th>Availability</th> </tr> </thead> <tbody> <tr> <td>Normal Mode On, Idle Mode Off, Sleep Out</td> <td>Yes</td> </tr> <tr> <td>Normal Mode On, Idle Mode On, Sleep Out</td> <td>Yes</td> </tr> <tr> <td>Sleep In</td> <td>Yes</td> </tr> </tbody> </table>											Status	Availability	Normal Mode On, Idle Mode Off, Sleep Out	Yes	Normal Mode On, Idle Mode On, Sleep Out	Yes	Sleep In	Yes
Status	Availability																		
Normal Mode On, Idle Mode Off, Sleep Out	Yes																		
Normal Mode On, Idle Mode On, Sleep Out	Yes																		
Sleep In	Yes																		
Default	<table border="1"> <thead> <tr> <th>Status</th> <th>Default Value</th> </tr> </thead> <tbody> <tr> <td>Power On Sequence</td> <td>00h_00h_00h</td> </tr> <tr> <td>S/W Reset</td> <td>00h_00h_00h</td> </tr> <tr> <td>H/W Reset</td> <td>00h_00h_00h</td> </tr> </tbody> </table>											Status	Default Value	Power On Sequence	00h_00h_00h	S/W Reset	00h_00h_00h	H/W Reset	00h_00h_00h
Status	Default Value																		
Power On Sequence	00h_00h_00h																		
S/W Reset	00h_00h_00h																		
H/W Reset	00h_00h_00h																		

5.4.18. NV Memory Status Read (E6h~E9h)

Command Page			Page 1																																																																																
Address	Parameter	W/R	D7	D6	D5	D4	D3	D2	D1	D0	Default																																																																								
E6h	1st	R	0	ID2_MK[2:0]			0	ID1_MK[2:0]			00h																																																																								
E7h	1st	R	0	0	0	0	0	ID3_MK[2:0]			00h																																																																								
E8h	1st	R	GAMMA P_MK	GAMMA N_MK	VCM2_MK[2:0]			VCM1_MK[2:0]			00h																																																																								
E9h	1st	R	OTP_BU SY	0	0	0	0	0	0	0	00h																																																																								
Description	<p>These registers uses a mark to record the NV memory programmed time. The bits are increase "+1" automatically after writing the PGM_DATA [7:0] to the NV memory.</p> <p>ID1_MK[2:0]/ID2_MK[2:0]:</p> <table border="1"> <thead> <tr> <th colspan="3">ID1_MK[2:0] / ID2_MK[2:0]</th> <th>Description</th> </tr> </thead> <tbody> <tr> <td>0</td> <td>0</td> <td>0</td> <td>No Programmed</td> </tr> <tr> <td>0</td> <td>0</td> <td>1</td> <td>Programmed 1 time already</td> </tr> <tr> <td>0</td> <td>1</td> <td>1</td> <td>Programmed 2 times already</td> </tr> <tr> <td>1</td> <td>1</td> <td>1</td> <td>Programmed 3 times already</td> </tr> </tbody> </table> <p>ID3_MK[2:0]:</p> <table border="1"> <thead> <tr> <th colspan="3">ID3_MK[2:0]</th> <th>Description</th> </tr> </thead> <tbody> <tr> <td>0</td> <td>0</td> <td>0</td> <td>No Programmed</td> </tr> <tr> <td>0</td> <td>0</td> <td>1</td> <td>Programmed 1 time already</td> </tr> <tr> <td>0</td> <td>1</td> <td>1</td> <td>Programmed 2 times already</td> </tr> <tr> <td>1</td> <td>1</td> <td>1</td> <td>Programmed 3 times already</td> </tr> </tbody> </table> <p>VCM1_MK[2:0] /VCM2_MK[2:0]:</p> <table border="1"> <thead> <tr> <th colspan="3">VCM1_MK[2:0] / VCM2_MK[2:0]</th> <th>Description</th> </tr> </thead> <tbody> <tr> <td>0</td> <td>0</td> <td>0</td> <td>No Programmed</td> </tr> <tr> <td>0</td> <td>0</td> <td>1</td> <td>Programmed 1 time already</td> </tr> <tr> <td>0</td> <td>1</td> <td>1</td> <td>Programmed 2 times already</td> </tr> <tr> <td>1</td> <td>1</td> <td>1</td> <td>Programmed 3 times already</td> </tr> </tbody> </table> <p>GAMP_MK / GAMN_MK :</p> <table border="1"> <thead> <tr> <th>GAMP_MK / GAMN_MK</th> <th>Description</th> </tr> </thead> <tbody> <tr> <td>0</td> <td>No Programmed</td> </tr> <tr> <td>1</td> <td>Programmed 1 time already</td> </tr> </tbody> </table> <p>OTP BUSY: The status bit of the NV memory programming.</p> <table border="1"> <thead> <tr> <th>OTP_BUSY</th> <th>The Status of NV Memory</th> </tr> </thead> <tbody> <tr> <td>0</td> <td>Idle</td> </tr> <tr> <td>1</td> <td>Busy</td> </tr> </tbody> </table>											ID1_MK[2:0] / ID2_MK[2:0]			Description	0	0	0	No Programmed	0	0	1	Programmed 1 time already	0	1	1	Programmed 2 times already	1	1	1	Programmed 3 times already	ID3_MK[2:0]			Description	0	0	0	No Programmed	0	0	1	Programmed 1 time already	0	1	1	Programmed 2 times already	1	1	1	Programmed 3 times already	VCM1_MK[2:0] / VCM2_MK[2:0]			Description	0	0	0	No Programmed	0	0	1	Programmed 1 time already	0	1	1	Programmed 2 times already	1	1	1	Programmed 3 times already	GAMP_MK / GAMN_MK	Description	0	No Programmed	1	Programmed 1 time already	OTP_BUSY	The Status of NV Memory	0	Idle	1	Busy
	ID1_MK[2:0] / ID2_MK[2:0]			Description																																																																															
	0	0	0	No Programmed																																																																															
	0	0	1	Programmed 1 time already																																																																															
	0	1	1	Programmed 2 times already																																																																															
	1	1	1	Programmed 3 times already																																																																															
	ID3_MK[2:0]			Description																																																																															
	0	0	0	No Programmed																																																																															
	0	0	1	Programmed 1 time already																																																																															
	0	1	1	Programmed 2 times already																																																																															
1	1	1	Programmed 3 times already																																																																																
VCM1_MK[2:0] / VCM2_MK[2:0]			Description																																																																																
0	0	0	No Programmed																																																																																
0	0	1	Programmed 1 time already																																																																																
0	1	1	Programmed 2 times already																																																																																
1	1	1	Programmed 3 times already																																																																																
GAMP_MK / GAMN_MK	Description																																																																																		
0	No Programmed																																																																																		
1	Programmed 1 time already																																																																																		
OTP_BUSY	The Status of NV Memory																																																																																		
0	Idle																																																																																		
1	Busy																																																																																		
Restriction	None																																																																																		
Register Availability	<table border="1"> <thead> <tr> <th>Status</th> <th>Availability</th> </tr> </thead> <tbody> <tr> <td>Normal Mode On, Idle Mode Off, Sleep Out</td> <td>Yes</td> </tr> <tr> <td>Normal Mode On, Idle Mode On, Sleep Out</td> <td>Yes</td> </tr> <tr> <td>Sleep In</td> <td>Yes</td> </tr> </tbody> </table>											Status	Availability	Normal Mode On, Idle Mode Off, Sleep Out	Yes	Normal Mode On, Idle Mode On, Sleep Out	Yes	Sleep In	Yes																																																																
Status	Availability																																																																																		
Normal Mode On, Idle Mode Off, Sleep Out	Yes																																																																																		
Normal Mode On, Idle Mode On, Sleep Out	Yes																																																																																		
Sleep In	Yes																																																																																		

Default	Status	Default Value
	Power On Sequence	00h_00h_00h_00h
	S/W Reset	00h_00h_00h_00h
	H/W Reset	00h_00h_00h_00h

5.4.19. Time Stamp (F0h~F1h)

Command Page			Page 1																
Address	Parameter	W/R	D7	D6	D5	D4	D3	D2	D1	D0	Default								
F0h	1st	W/R	Time_Stamp_Week[7:0]								00h								
F1h	1st	W/R	Time_Stamp_Year[7:0]								00h								
Description	<p>This command identifies the display module's manufacture date</p> <p>Time_Stamp_Week[7:0]: Week of manufacture.</p> <p>Time_Stamp_Year[7:0]: Year of manufacture.</p>																		
Restriction																			
Register Availability	<table border="1"> <thead> <tr> <th>Status</th> <th>Availability</th> </tr> </thead> <tbody> <tr> <td>Normal Mode On, Idle Mode Off, Sleep Out</td> <td>Yes</td> </tr> <tr> <td>Normal Mode On, Idle Mode On, Sleep Out</td> <td>Yes</td> </tr> <tr> <td>Sleep In</td> <td>Yes</td> </tr> </tbody> </table>											Status	Availability	Normal Mode On, Idle Mode Off, Sleep Out	Yes	Normal Mode On, Idle Mode On, Sleep Out	Yes	Sleep In	Yes
Status	Availability																		
Normal Mode On, Idle Mode Off, Sleep Out	Yes																		
Normal Mode On, Idle Mode On, Sleep Out	Yes																		
Sleep In	Yes																		
Default	<table border="1"> <thead> <tr> <th>Status</th> <th>Default Value</th> </tr> </thead> <tbody> <tr> <td>Power On Sequence</td> <td>00h_00h</td> </tr> <tr> <td>S/W Reset</td> <td>00h_00h</td> </tr> <tr> <td>H/W Reset</td> <td>00h_00h</td> </tr> </tbody> </table>											Status	Default Value	Power On Sequence	00h_00h	S/W Reset	00h_00h	H/W Reset	00h_00h
Status	Default Value																		
Power On Sequence	00h_00h																		
S/W Reset	00h_00h																		
H/W Reset	00h_00h																		

5.4.20. EXTC Command Set Enable Register (FFh)

Command Page			Page 1																																		
Address	Parameter	W/R	D7	D6	D5	D4	D3	D2	D1	D0	Default																										
FFh	1st	W	1	0	0	1	1	0	0	0	98h																										
	2nd	W	1	0	0	0	0	0	0	1	81h																										
	3rd	W	PAGE[7:0]								01h																										
Description	<p>PAGE[7:0]: Set the command page.</p> <table border="1"> <thead> <tr> <th>PAGE[7:0]</th> <th>Command Page</th> </tr> </thead> <tbody> <tr><td>00h</td><td>Page 0</td></tr> <tr><td>01h</td><td>Page 1</td></tr> <tr><td>02h</td><td>Page 2</td></tr> <tr><td>03h</td><td>Page 3</td></tr> <tr><td>04h</td><td>Page 4</td></tr> <tr><td>05h</td><td>Page 5</td></tr> <tr><td>06h</td><td>Page 6</td></tr> <tr><td>07h</td><td>Page 7</td></tr> <tr><td>08h</td><td>Page 8</td></tr> <tr><td>09h</td><td>Page 9</td></tr> <tr><td>0Ah</td><td>Page 10</td></tr> <tr><td>Others</td><td>Reserved</td></tr> </tbody> </table> <p>Set the register, 1st Parameter = 98h, 2nd Parameter = 81h, 3rd Parameter = Page value to enable "Page command set" available</p> <p>See section "5.1 Command Flow".</p>											PAGE[7:0]	Command Page	00h	Page 0	01h	Page 1	02h	Page 2	03h	Page 3	04h	Page 4	05h	Page 5	06h	Page 6	07h	Page 7	08h	Page 8	09h	Page 9	0Ah	Page 10	Others	Reserved
	PAGE[7:0]	Command Page																																			
	00h	Page 0																																			
	01h	Page 1																																			
	02h	Page 2																																			
	03h	Page 3																																			
	04h	Page 4																																			
	05h	Page 5																																			
	06h	Page 6																																			
	07h	Page 7																																			
	08h	Page 8																																			
	09h	Page 9																																			
	0Ah	Page 10																																			
Others	Reserved																																				
Restriction	None																																				
Register Availability	<table border="1"> <thead> <tr> <th>Status</th> <th>Availability</th> </tr> </thead> <tbody> <tr> <td>Normal Mode On, Idle Mode Off, Sleep Out</td> <td>Yes</td> </tr> <tr> <td>Normal Mode On, Idle Mode On, Sleep Out</td> <td>Yes</td> </tr> <tr> <td>Sleep In</td> <td>Yes</td> </tr> </tbody> </table>											Status	Availability	Normal Mode On, Idle Mode Off, Sleep Out	Yes	Normal Mode On, Idle Mode On, Sleep Out	Yes	Sleep In	Yes																		
Status	Availability																																				
Normal Mode On, Idle Mode Off, Sleep Out	Yes																																				
Normal Mode On, Idle Mode On, Sleep Out	Yes																																				
Sleep In	Yes																																				
Default	<table border="1"> <thead> <tr> <th>Status</th> <th>Default Value</th> </tr> </thead> <tbody> <tr> <td>Power On Sequence</td> <td>01h</td> </tr> <tr> <td>S/W Reset</td> <td>01h</td> </tr> <tr> <td>H/W Reset</td> <td>01h</td> </tr> </tbody> </table>											Status	Default Value	Power On Sequence	01h	S/W Reset	01h	H/W Reset	01h																		
Status	Default Value																																				
Power On Sequence	01h																																				
S/W Reset	01h																																				
H/W Reset	01h																																				

5.5. Page 2 Command Description

5.5.1. Dynamic Backlight Control 1 (03h~05h)

Command Page			Page 2																																												
Address	Parameter	W/R	D7	D6	D5	D4	D3	D2	D1	D0	Default																																				
03h	1st	W/R	0	TT_STP_MED[2:0]			1	TT_STP_LOW[2:0]			29h																																				
04h	1st	W/R	0	ST_TIM_LOW[2:0]			0	TT_STP_HIGH[2:0]			14h																																				
05h	1st	W/R	0	ST_TIM_HIGH[2:0]			0	ST_TIM_MED[2:0]			32h																																				
Description	<p>TT_STP_HIGH[2:0]: This parameter is used set the dimming transition step for CABC high enhancement.</p> <p>TT_STP_MED[2:0]: This parameter is used set the dimming transition step for CABC medium enhancement.</p> <p>TT_STP_LOW[2:0]: This parameter is used set the dimming transition step for CABC low enhancement.</p> <table border="1"> <thead> <tr> <th>TT_STP_HIGH[2:0] TT_STP_MED[2:0] TT_STP_LOW[2:0]</th> <th>Description</th> </tr> </thead> <tbody> <tr><td>0h</td><td>1 step</td></tr> <tr><td>1h</td><td>2 step</td></tr> <tr><td>2h</td><td>4 step</td></tr> <tr><td>3h</td><td>8 step</td></tr> <tr><td>4h</td><td>16 step</td></tr> <tr><td>5h</td><td>32 step</td></tr> <tr><td>6h</td><td>64 step</td></tr> <tr><td>7h</td><td>128 step</td></tr> </tbody> </table> <p>ST_TIM_HIGH[2:0]: This parameter is used set the dimming time for CABC high enhancement.</p> <p>ST_TIM_MED[2:0]: This parameter is used set the dimming time for CABC medium enhancement.</p> <p>ST_TIM_LOW[2:0]: This parameter is used set the dimming time for CABC low enhancement.</p> <table border="1"> <thead> <tr> <th>ST_TIM_HIGH[2:0] ST_TIM_MED[2:0] ST_TIM_LOW[2:0]</th> <th>Description</th> </tr> </thead> <tbody> <tr><td>0h</td><td>1 frame</td></tr> <tr><td>1h</td><td>2 frame</td></tr> <tr><td>2h</td><td>4 frame</td></tr> <tr><td>3h</td><td>8 frame</td></tr> <tr><td>4h</td><td>16 frame</td></tr> <tr><td>5h</td><td>32 frame</td></tr> <tr><td>6h</td><td>64 frame</td></tr> <tr><td>7h</td><td>128 frame</td></tr> </tbody> </table>											TT_STP_HIGH[2:0] TT_STP_MED[2:0] TT_STP_LOW[2:0]	Description	0h	1 step	1h	2 step	2h	4 step	3h	8 step	4h	16 step	5h	32 step	6h	64 step	7h	128 step	ST_TIM_HIGH[2:0] ST_TIM_MED[2:0] ST_TIM_LOW[2:0]	Description	0h	1 frame	1h	2 frame	2h	4 frame	3h	8 frame	4h	16 frame	5h	32 frame	6h	64 frame	7h	128 frame
	TT_STP_HIGH[2:0] TT_STP_MED[2:0] TT_STP_LOW[2:0]	Description																																													
0h	1 step																																														
1h	2 step																																														
2h	4 step																																														
3h	8 step																																														
4h	16 step																																														
5h	32 step																																														
6h	64 step																																														
7h	128 step																																														
ST_TIM_HIGH[2:0] ST_TIM_MED[2:0] ST_TIM_LOW[2:0]	Description																																														
0h	1 frame																																														
1h	2 frame																																														
2h	4 frame																																														
3h	8 frame																																														
4h	16 frame																																														
5h	32 frame																																														
6h	64 frame																																														
7h	128 frame																																														
Restriction																																															
Register Availability	<table border="1"> <thead> <tr> <th>Status</th> <th>Availability</th> </tr> </thead> <tbody> <tr> <td>Normal Mode On, Idle Mode Off, Sleep Out</td> <td>Yes</td> </tr> <tr> <td>Normal Mode On, Idle Mode On, Sleep Out</td> <td>Yes</td> </tr> <tr> <td>Sleep In</td> <td>Yes</td> </tr> </tbody> </table>											Status	Availability	Normal Mode On, Idle Mode Off, Sleep Out	Yes	Normal Mode On, Idle Mode On, Sleep Out	Yes	Sleep In	Yes																												
Status	Availability																																														
Normal Mode On, Idle Mode Off, Sleep Out	Yes																																														
Normal Mode On, Idle Mode On, Sleep Out	Yes																																														
Sleep In	Yes																																														
Default	<table border="1"> <thead> <tr> <th>Status</th> <th>Default Value</th> </tr> </thead> <tbody> <tr> <td>Power On Sequence</td> <td>29h_14h_32h</td> </tr> <tr> <td>S/W Reset</td> <td>29h_14h_32h</td> </tr> <tr> <td>H/W Reset</td> <td>29h_14h_32h</td> </tr> </tbody> </table>											Status	Default Value	Power On Sequence	29h_14h_32h	S/W Reset	29h_14h_32h	H/W Reset	29h_14h_32h																												
Status	Default Value																																														
Power On Sequence	29h_14h_32h																																														
S/W Reset	29h_14h_32h																																														
H/W Reset	29h_14h_32h																																														

5.5.2. Dynamic Backlight Control 2 (06h~07h)

Command Page		Page 2																																																				
Address	Parameter	W/R	D7	D6	D5	D4	D3	D2	D1	D0	Default																																											
06h	1st	W/R	0	PWM_DUTY_PRECISION[2:0]			0	LEDPW_M_POL	LEDON_POL	LEDON	00h																																											
07h	1st	W/R	PWM_DIV[7:0]								0Eh																																											
Description	<p>LEDON: The bit is used to define LEDON enable.</p> <p>LEDON_POL: The bit is used to define polarity of LEDON.</p> <p>LEDPWM_POL: The bit is used to define polarity of LEDPWM signal.</p> <table border="1"> <thead> <tr> <th>BL</th> <th>LEDPWM_POL</th> <th>LEDPWM pin</th> </tr> </thead> <tbody> <tr> <td>0</td> <td>0</td> <td>Always low</td> </tr> <tr> <td>0</td> <td>1</td> <td>Always high</td> </tr> <tr> <td>1</td> <td>0</td> <td>Original polarity of LEDPWM signal</td> </tr> <tr> <td>1</td> <td>1</td> <td>Inversed polarity of LEDPWM signal</td> </tr> </tbody> </table> <p>PWM_DUTY_PRECISION[2:0] / PWM_DIV[7:0]: LEDPWM output period control. This command is used to adjust the PWM waveform period of PWM_OUT. The PWM period is calculated using the following equation.</p> $f_{LEDPWM} = \frac{32 \text{ MHz}}{(PWM_DIV[7:0] + 1) \times PWM_DUTY_PRECISION}$ <table border="1"> <thead> <tr> <th>PWM_DUTY_PRECISION[2:0]</th> <th>PWM_DUTY_PRECISION</th> <th>f_{LEDPWM} (MAX) (PWM_DIV[7:0]=0)</th> <th>f_{LEDPWM} (min) (PWM_DIV[7:0]=255)</th> </tr> </thead> <tbody> <tr> <td>0h</td> <td>4096</td> <td>7.8 KHz</td> <td>31 Hz</td> </tr> <tr> <td>1h</td> <td>2048</td> <td>15.6 KHz</td> <td>61 Hz</td> </tr> <tr> <td>2h</td> <td>1024</td> <td>31.2 KHz</td> <td>122 Hz</td> </tr> <tr> <td>3h</td> <td>512</td> <td>62.5 KHz</td> <td>244 Hz</td> </tr> <tr> <td>4h</td> <td>256</td> <td>125 KHz</td> <td>488 Hz</td> </tr> <tr> <td>5h~7h</td> <td>Reserved</td> <td>X</td> <td>X</td> </tr> </tbody> </table> <p>Note : The output frequency tolerance of internal frequency divider in CABC is ±10%</p> <p>X = void.</p>											BL	LEDPWM_POL	LEDPWM pin	0	0	Always low	0	1	Always high	1	0	Original polarity of LEDPWM signal	1	1	Inversed polarity of LEDPWM signal	PWM_DUTY_PRECISION[2:0]	PWM_DUTY_PRECISION	f _{LEDPWM} (MAX) (PWM_DIV[7:0]=0)	f _{LEDPWM} (min) (PWM_DIV[7:0]=255)	0h	4096	7.8 KHz	31 Hz	1h	2048	15.6 KHz	61 Hz	2h	1024	31.2 KHz	122 Hz	3h	512	62.5 KHz	244 Hz	4h	256	125 KHz	488 Hz	5h~7h	Reserved	X	X
	BL	LEDPWM_POL	LEDPWM pin																																																			
	0	0	Always low																																																			
	0	1	Always high																																																			
	1	0	Original polarity of LEDPWM signal																																																			
	1	1	Inversed polarity of LEDPWM signal																																																			
	PWM_DUTY_PRECISION[2:0]	PWM_DUTY_PRECISION	f _{LEDPWM} (MAX) (PWM_DIV[7:0]=0)	f _{LEDPWM} (min) (PWM_DIV[7:0]=255)																																																		
	0h	4096	7.8 KHz	31 Hz																																																		
	1h	2048	15.6 KHz	61 Hz																																																		
	2h	1024	31.2 KHz	122 Hz																																																		
3h	512	62.5 KHz	244 Hz																																																			
4h	256	125 KHz	488 Hz																																																			
5h~7h	Reserved	X	X																																																			
Restriction																																																						
Register Availability	<table border="1"> <thead> <tr> <th>Status</th> <th>Availability</th> </tr> </thead> <tbody> <tr> <td>Normal Mode On, Idle Mode Off, Sleep Out</td> <td>Yes</td> </tr> <tr> <td>Normal Mode On, Idle Mode On, Sleep Out</td> <td>Yes</td> </tr> <tr> <td>Sleep In</td> <td>Yes</td> </tr> </tbody> </table>											Status	Availability	Normal Mode On, Idle Mode Off, Sleep Out	Yes	Normal Mode On, Idle Mode On, Sleep Out	Yes	Sleep In	Yes																																			
Status	Availability																																																					
Normal Mode On, Idle Mode Off, Sleep Out	Yes																																																					
Normal Mode On, Idle Mode On, Sleep Out	Yes																																																					
Sleep In	Yes																																																					
Default	<table border="1"> <thead> <tr> <th>Status</th> <th>Default Value</th> </tr> </thead> <tbody> <tr> <td>Power On Sequence</td> <td>00h_0Eh</td> </tr> <tr> <td>S/W Reset</td> <td>00h_0Eh</td> </tr> <tr> <td>H/W Reset</td> <td>00h_0Eh</td> </tr> </tbody> </table>											Status	Default Value	Power On Sequence	00h_0Eh	S/W Reset	00h_0Eh	H/W Reset	00h_0Eh																																			
Status	Default Value																																																					
Power On Sequence	00h_0Eh																																																					
S/W Reset	00h_0Eh																																																					
H/W Reset	00h_0Eh																																																					

5.5.3. IIE Function Control (10h~19h)

Command Page			Page 2																																								
Address	Parameter	W/R	D7	D6	D5	D4	D3	D2	D1	D0	Default																																
10h	1st	W/R	0	0	0	0	0	PRT_EN	SKIN_EN	0	06h																																
11h	1st	W/R	0	AUTO_MEAN	0	0	CN_EN	CN_INV	SHP_EN	0	00h																																
12h	1st	W/R	0	0	0	0	0	0	CN_LV[1:0]		02h																																
13h	1st	W/R	0	0	1	0	SRE_MIDIV_LV[1:0]		0	0	20h																																
15h	1st	W/R	RGB_MEAN[7:0]								80h																																
16h	1st	W/R	SRE_HYSTERESIS_EN	0	0	SRE_DIM_EN	SRE_SC_EN	SRE_CE_EN	0	0	1Ch																																
17h	1st	W/R	0	SRE_OFFSETS[2:0]			0	SRE_DIM_STP[2:0]			01h																																
18h	1st	W/R	SRE_DIM_FRAME[7:0]									08h																															
19h	1st	W/R	SRE_SC_GAIN_ADJ[2:0]			SRE_HYSTERESIS_LIMIT[4:0]				C0h																																	
Description	<p>PRT_EN: Enable the over-saturation protection of saturation enhancement.</p> <p>SKIN_EN: Enable the skin-tone protection of saturation enhancement.</p> <p>AUTO_MEAN: Enable auto image mean calculation RGB_MEAN[7:0] is not available when AUTO_MEAN=1h.</p> <p>CN_EN: Enable contrast enhancement.</p> <p>CN_INV: Select contrast enhancement Function.</p> <table border="1"> <thead> <tr> <th>CN_INV</th> <th>Contrast Function</th> </tr> </thead> <tbody> <tr> <td>0</td> <td>Contrast increase</td> </tr> <tr> <td>1</td> <td>Contrast decrease</td> </tr> </tbody> </table> <p>SHP_EN: Enable sharpness enhancement.</p> <p>CN_LV[1:0] : Define contrast enhancement level.</p> <p>SRE_MIDIV_LV[1:0] : Define SRE medium level enhancement select.</p> <table border="1"> <thead> <tr> <th>SRE_MIDIV_LV[1:0]</th> <th>Enhancement level</th> </tr> </thead> <tbody> <tr> <td>00h / 11h</td> <td>Level_M</td> </tr> <tr> <td>01h</td> <td>Level_H</td> </tr> <tr> <td>10h</td> <td>Level_L</td> </tr> </tbody> </table> <p>RGB_MEAN[7:0]: Setting image mean value, available when AUTO_MEAN=0h.</p> <p>SRE_HYSTERESIS_EN: SRE hysteresis mode enable signal.</p> <p>SRE_DIM_EN: SRE dimming function enable signal.</p> <p>SRE_SC_EN: SRE saturation compensation enable.</p> <p>SRE_CE_EN: SRE contrast enhancement enable.</p> <p>SRE_OFFSETS[2:0]: SRE offset value</p> <p>SRE_DIM_STP[2:0]: Setting the number of dimming steps for transition</p> <table border="1"> <thead> <tr> <th>SRE_DIM_STP[2:0]</th> <th>Description</th> </tr> </thead> <tbody> <tr> <td>0h</td> <td>2 step</td> </tr> <tr> <td>1h</td> <td>4 step</td> </tr> <tr> <td>2h</td> <td>8 step</td> </tr> <tr> <td>3h</td> <td>16 step</td> </tr> <tr> <td>4h</td> <td>32 step</td> </tr> <tr> <td>5h</td> <td>64 step</td> </tr> <tr> <td>6h</td> <td>128 step</td> </tr> <tr> <td>7h</td> <td>256 step</td> </tr> </tbody> </table> <p>SRE_DIM_FRAME[7:0]: Setting the step time as frame units for each dimming step</p>											CN_INV	Contrast Function	0	Contrast increase	1	Contrast decrease	SRE_MIDIV_LV[1:0]	Enhancement level	00h / 11h	Level_M	01h	Level_H	10h	Level_L	SRE_DIM_STP[2:0]	Description	0h	2 step	1h	4 step	2h	8 step	3h	16 step	4h	32 step	5h	64 step	6h	128 step	7h	256 step
CN_INV	Contrast Function																																										
0	Contrast increase																																										
1	Contrast decrease																																										
SRE_MIDIV_LV[1:0]	Enhancement level																																										
00h / 11h	Level_M																																										
01h	Level_H																																										
10h	Level_L																																										
SRE_DIM_STP[2:0]	Description																																										
0h	2 step																																										
1h	4 step																																										
2h	8 step																																										
3h	16 step																																										
4h	32 step																																										
5h	64 step																																										
6h	128 step																																										
7h	256 step																																										

	<table border="1"> <thead> <tr> <th>SRE_DIM_FRAME[7:0]</th> <th>Description</th> </tr> </thead> <tbody> <tr> <td>0h~2h</td> <td>2 frame</td> </tr> <tr> <td>3</td> <td>4 frame</td> </tr> <tr> <td>4</td> <td>4 frame</td> </tr> <tr> <td>5</td> <td>5 frame</td> </tr> <tr> <td>6</td> <td>6 frame</td> </tr> <tr> <td>:</td> <td>:</td> </tr> <tr> <td>:</td> <td>:</td> </tr> <tr> <td>254</td> <td>254 frame</td> </tr> <tr> <td>255</td> <td>255 frame</td> </tr> </tbody> </table> <p>SRE_SC_GAIN_ADJ[2:0]: SRE saturation compensation gain value</p> <p>SRE_HYSTERESIS_LIMIT[4:0]: SRE hysteresis limit value when hysteresis mode on</p>	SRE_DIM_FRAME[7:0]	Description	0h~2h	2 frame	3	4 frame	4	4 frame	5	5 frame	6	6 frame	:	:	:	:	254	254 frame	255	255 frame
SRE_DIM_FRAME[7:0]	Description																				
0h~2h	2 frame																				
3	4 frame																				
4	4 frame																				
5	5 frame																				
6	6 frame																				
:	:																				
:	:																				
254	254 frame																				
255	255 frame																				
Restriction	None																				
Register Availability	<table border="1"> <thead> <tr> <th>Status</th> <th>Availability</th> </tr> </thead> <tbody> <tr> <td>Normal Mode On, Idle Mode Off, Sleep Out</td> <td>Yes</td> </tr> <tr> <td>Normal Mode On, Idle Mode On, Sleep Out</td> <td>Yes</td> </tr> <tr> <td>Sleep In</td> <td>Yes</td> </tr> </tbody> </table>	Status	Availability	Normal Mode On, Idle Mode Off, Sleep Out	Yes	Normal Mode On, Idle Mode On, Sleep Out	Yes	Sleep In	Yes												
Status	Availability																				
Normal Mode On, Idle Mode Off, Sleep Out	Yes																				
Normal Mode On, Idle Mode On, Sleep Out	Yes																				
Sleep In	Yes																				
Default	<table border="1"> <thead> <tr> <th>Status</th> <th>Default Value</th> </tr> </thead> <tbody> <tr> <td>Power On Sequence</td> <td>06h_00h_02h_20h_80h_1Ch_01h_08h_C0h</td> </tr> <tr> <td>S/W Reset</td> <td>06h_00h_02h_20h_80h_1Ch_01h_08h_C0h</td> </tr> <tr> <td>H/W Reset</td> <td>06h_00h_02h_20h_80h_1Ch_01h_08h_C0h</td> </tr> </tbody> </table>	Status	Default Value	Power On Sequence	06h_00h_02h_20h_80h_1Ch_01h_08h_C0h	S/W Reset	06h_00h_02h_20h_80h_1Ch_01h_08h_C0h	H/W Reset	06h_00h_02h_20h_80h_1Ch_01h_08h_C0h												
Status	Default Value																				
Power On Sequence	06h_00h_02h_20h_80h_1Ch_01h_08h_C0h																				
S/W Reset	06h_00h_02h_20h_80h_1Ch_01h_08h_C0h																				
H/W Reset	06h_00h_02h_20h_80h_1Ch_01h_08h_C0h																				

5.5.4. IIE Saturation Enhancement Control 1 (1Ah~1Ch)

Command Page			Page 2																																																																												
Address	Parameter	W/R	D7	D6	D5	D4	D3	D2	D1	D0	Default																																																																				
1Ah	1st	W/R	0	0	SE_RATIO_L[5:0]					07h																																																																					
1Bh	1st	W/R	0	0	SE_RATIO_M[5:0]					09h																																																																					
1Ch	1st	W/R	0	0	SE_RATIO_H[5:0]					0Ch																																																																					
Description	<p>SE_RATIO_L[5:0]: Define low saturation enhancement level of User Command 55h (Page0_R55h).</p> <p>SE_RATIO_M[5:0]: Define medium saturation enhancement level of User Command 55h (Page0_R55h).</p> <p>SE_RATIO_H[5:0]: Define high saturation enhancement level of User Command 55h (Page0_R55h).</p> <p style="text-align: center;">$Saturation_{enhanced} = Saturation_{original} + (Saturation_{original} \times SE_RATIO)$</p> <table border="1" style="margin-left: auto; margin-right: auto;"> <thead> <tr> <th>SE_RATIO_L[5:0] SE_RATIO_M[5:0] SE_RATIO_H[5:0]</th> <th>Ratio (Dec)</th> <th>SE_RATIO_L[5:0] SE_RATIO_M[5:0] SE_RATIO_H[5:0]</th> <th>Ratio (Dec)</th> </tr> </thead> <tbody> <tr><td>00h</td><td>0.0</td><td>10h</td><td>1.0</td></tr> <tr><td>01h</td><td>0.0625</td><td>11h</td><td>1.0625</td></tr> <tr><td>02h</td><td>0.125</td><td>12h</td><td>1.125</td></tr> <tr><td>03h</td><td>0.1875</td><td>13h</td><td>1.1875</td></tr> <tr><td>04h</td><td>0.25</td><td>14h</td><td>1.25</td></tr> <tr><td>05h</td><td>0.3125</td><td>15h</td><td>1.3125</td></tr> <tr><td>06h</td><td>0.375</td><td>16h</td><td>1.375</td></tr> <tr><td>07h</td><td>0.4375</td><td>17h</td><td>1.4375</td></tr> <tr><td>08h</td><td>0.5</td><td>18h</td><td>1.5</td></tr> <tr><td>09h</td><td>0.5625</td><td>19h</td><td>1.5625</td></tr> <tr><td>0Ah</td><td>0.625</td><td>1Ah</td><td>1.625</td></tr> <tr><td>0Bh</td><td>0.6875</td><td>1Bh</td><td>1.6875</td></tr> <tr><td>0Ch</td><td>0.75</td><td>1Ch</td><td>1.75</td></tr> <tr><td>0Dh</td><td>0.8125</td><td>1Dh</td><td>1.8125</td></tr> <tr><td>0Eh</td><td>0.875</td><td>1Eh</td><td>1.875</td></tr> <tr><td>0Fh</td><td>0.9375</td><td>1Fh</td><td>1.9375</td></tr> </tbody> </table>											SE_RATIO_L[5:0] SE_RATIO_M[5:0] SE_RATIO_H[5:0]	Ratio (Dec)	SE_RATIO_L[5:0] SE_RATIO_M[5:0] SE_RATIO_H[5:0]	Ratio (Dec)	00h	0.0	10h	1.0	01h	0.0625	11h	1.0625	02h	0.125	12h	1.125	03h	0.1875	13h	1.1875	04h	0.25	14h	1.25	05h	0.3125	15h	1.3125	06h	0.375	16h	1.375	07h	0.4375	17h	1.4375	08h	0.5	18h	1.5	09h	0.5625	19h	1.5625	0Ah	0.625	1Ah	1.625	0Bh	0.6875	1Bh	1.6875	0Ch	0.75	1Ch	1.75	0Dh	0.8125	1Dh	1.8125	0Eh	0.875	1Eh	1.875	0Fh	0.9375	1Fh	1.9375
	SE_RATIO_L[5:0] SE_RATIO_M[5:0] SE_RATIO_H[5:0]	Ratio (Dec)	SE_RATIO_L[5:0] SE_RATIO_M[5:0] SE_RATIO_H[5:0]	Ratio (Dec)																																																																											
	00h	0.0	10h	1.0																																																																											
	01h	0.0625	11h	1.0625																																																																											
	02h	0.125	12h	1.125																																																																											
	03h	0.1875	13h	1.1875																																																																											
	04h	0.25	14h	1.25																																																																											
	05h	0.3125	15h	1.3125																																																																											
	06h	0.375	16h	1.375																																																																											
	07h	0.4375	17h	1.4375																																																																											
	08h	0.5	18h	1.5																																																																											
	09h	0.5625	19h	1.5625																																																																											
	0Ah	0.625	1Ah	1.625																																																																											
	0Bh	0.6875	1Bh	1.6875																																																																											
	0Ch	0.75	1Ch	1.75																																																																											
	0Dh	0.8125	1Dh	1.8125																																																																											
	0Eh	0.875	1Eh	1.875																																																																											
0Fh	0.9375	1Fh	1.9375																																																																												
Restriction	None																																																																														
Register Availability	<table border="1" style="margin-left: auto; margin-right: auto;"> <thead> <tr> <th>Status</th> <th>Availability</th> </tr> </thead> <tbody> <tr> <td>Normal Mode On, Idle Mode Off, Sleep Out</td> <td>Yes</td> </tr> <tr> <td>Normal Mode On, Idle Mode On, Sleep Out</td> <td>Yes</td> </tr> <tr> <td>Sleep In</td> <td>Yes</td> </tr> </tbody> </table>											Status	Availability	Normal Mode On, Idle Mode Off, Sleep Out	Yes	Normal Mode On, Idle Mode On, Sleep Out	Yes	Sleep In	Yes																																																												
Status	Availability																																																																														
Normal Mode On, Idle Mode Off, Sleep Out	Yes																																																																														
Normal Mode On, Idle Mode On, Sleep Out	Yes																																																																														
Sleep In	Yes																																																																														
Default	<table border="1" style="margin-left: auto; margin-right: auto;"> <thead> <tr> <th>Status</th> <th>Default Value</th> </tr> </thead> <tbody> <tr> <td>Power On Sequence</td> <td>07h_09h_0Ch</td> </tr> <tr> <td>S/W Reset</td> <td>07h_09h_0Ch</td> </tr> <tr> <td>H/W Reset</td> <td>07h_09h_0Ch</td> </tr> </tbody> </table>											Status	Default Value	Power On Sequence	07h_09h_0Ch	S/W Reset	07h_09h_0Ch	H/W Reset	07h_09h_0Ch																																																												
Status	Default Value																																																																														
Power On Sequence	07h_09h_0Ch																																																																														
S/W Reset	07h_09h_0Ch																																																																														
H/W Reset	07h_09h_0Ch																																																																														

5.5.5. IIE Saturation Protection Control (40h~4Fh)

Command Page			Page 2								
Address	Parameter	W/R	D7	D6	D5	D4	D3	D2	D1	D0	Default
40h	1st	W/R	0	0	0	LEVEL0_SR[4:0]				02h	
41h	1st	W/R	0	0	0	LEVEL1_SR[4:0]				04h	
42h	1st	W/R	0	0	0	LEVEL2_SR[4:0]				06h	
43h	1st	W/R	0	0	0	LEVEL3_SR[4:0]				08h	
44h	1st	W/R	0	0	0	LEVEL4_SR[4:0]				0Ah	
45h	1st	W/R	0	0	0	LEVEL5_SR[4:0]				0Ch	
46h	1st	W/R	0	0	0	LEVEL6_SR[4:0]				0Eh	
47h	1st	W/R	0	0	0	LEVEL7_SR[4:0]				0Eh	
48h	1st	W/R	0	0	0	LEVEL8_SR[4:0]				0Ch	
49h	1st	W/R	0	0	0	LEVEL9_SR[4:0]				0Ah	
4Ah	1st	W/R	0	0	0	LEVEL10_SR[4:0]				08h	
4Bh	1st	W/R	0	0	0	LEVEL11_SR[4:0]				06h	
4Ch	1st	W/R	0	0	0	LEVEL12_SR[4:0]				04h	
4Dh	1st	W/R	0	0	0	LEVEL13_SR[4:0]				03h	
4Eh	1st	W/R	0	0	0	LEVEL14_SR[4:0]				02h	
4Fh	1st	W/R	0	0	0	LEVEL15_SR[4:0]				00h	

Description	<p>This register is used to restrict the enhancement gain of saturation enhancement. This function is able to use when PRT_EN=1.</p> <p>LEVEL0_SR[4:0]: Adjust the weight value of saturation steps 0~15.</p> <p>LEVEL1_SR[4:0]: Adjust the weight value of saturation steps 16~31.</p> <p>LEVEL2_SR[4:0]: Adjust the weight value of saturation steps 32~47.</p> <p>LEVEL3_SR[4:0]: Adjust the weight value of saturation steps 48~63.</p> <p>LEVEL4_SR[4:0]: Adjust the weight value of saturation steps 64~79.</p> <p>LEVEL5_SR[4:0]: Adjust the weight value of saturation steps 80~95.</p> <p>LEVEL6_SR[4:0]: Adjust the weight value of saturation steps 96~111.</p> <p>LEVEL7_SR[4:0]: Adjust the weight value of saturation steps 128~143.</p> <p>LEVEL8_SR[4:0]: Adjust the weight value of saturation steps 144~159.</p> <p>LEVEL9_SR[4:0]: Adjust the weight value of saturation steps 160~175.</p> <p>LEVEL10_SR[4:0]: Adjust the weight value of saturation steps 176~191.</p> <p>LEVEL11_SR[4:0]: Adjust the weight value of saturation steps 192~207.</p> <p>LEVEL12_SR[4:0]: Adjust the weight value of saturation steps 208~223.</p> <p>LEVEL13_SR[4:0]: Adjust the weight value of saturation steps 224~239.</p> <p>LEVEL14_SR[4:0]: Adjust the weight value of saturation steps 240~255.</p> <p>LEVEL15_SR[4:0]: Adjust the weight value of saturation steps 256.</p> $\text{Saturation}_{\text{enhanced}} = \text{Saturation}_{\text{original}} + (\text{Saturation}_{\text{original}} \times SE_RATIO \times PRT_RATIO)$ <p style="text-align: right;">$PRT_RATIO = 0 \sim 1.0$</p>
-------------	--

Restriction	None								
Register Availability	<table border="1" data-bbox="608 719 1289 853"> <thead> <tr> <th>Status</th> <th>Availability</th> </tr> </thead> <tbody> <tr> <td>Normal Mode On, Idle Mode Off, Sleep Out</td> <td>Yes</td> </tr> <tr> <td>Normal Mode On, Idle Mode On, Sleep Out</td> <td>Yes</td> </tr> <tr> <td>Sleep In</td> <td>Yes</td> </tr> </tbody> </table>	Status	Availability	Normal Mode On, Idle Mode Off, Sleep Out	Yes	Normal Mode On, Idle Mode On, Sleep Out	Yes	Sleep In	Yes
Status	Availability								
Normal Mode On, Idle Mode Off, Sleep Out	Yes								
Normal Mode On, Idle Mode On, Sleep Out	Yes								
Sleep In	Yes								
Default	<table border="1" data-bbox="411 920 1485 1055"> <thead> <tr> <th>Status</th> <th>Default Value</th> </tr> </thead> <tbody> <tr> <td>Power On Sequence</td> <td>02h_04h_06h_08h_0Ah_0Ch_0Eh_0Eh_0Ch_0Ah_08h_06h_04h_03h_02h_00h</td> </tr> <tr> <td>S/W Reset</td> <td>02h_04h_06h_08h_0Ah_0Ch_0Eh_0Eh_0Ch_0Ah_08h_06h_04h_03h_02h_00h</td> </tr> <tr> <td>H/W Reset</td> <td>02h_04h_06h_08h_0Ah_0Ch_0Eh_0Eh_0Ch_0Ah_08h_06h_04h_03h_02h_00h</td> </tr> </tbody> </table>	Status	Default Value	Power On Sequence	02h_04h_06h_08h_0Ah_0Ch_0Eh_0Eh_0Ch_0Ah_08h_06h_04h_03h_02h_00h	S/W Reset	02h_04h_06h_08h_0Ah_0Ch_0Eh_0Eh_0Ch_0Ah_08h_06h_04h_03h_02h_00h	H/W Reset	02h_04h_06h_08h_0Ah_0Ch_0Eh_0Eh_0Ch_0Ah_08h_06h_04h_03h_02h_00h
Status	Default Value								
Power On Sequence	02h_04h_06h_08h_0Ah_0Ch_0Eh_0Eh_0Ch_0Ah_08h_06h_04h_03h_02h_00h								
S/W Reset	02h_04h_06h_08h_0Ah_0Ch_0Eh_0Eh_0Ch_0Ah_08h_06h_04h_03h_02h_00h								
H/W Reset	02h_04h_06h_08h_0Ah_0Ch_0Eh_0Eh_0Ch_0Ah_08h_06h_04h_03h_02h_00h								

5.5.6. IIE Sharpness Enhancement Control (5Ah~5Ch)

Command Page			Page 2																																																																												
Address	Parameter	W/R	D7	D6	D5	D4	D3	D2	D1	D0	Default																																																																				
5Ah	1st	W/R	0	0	0	SHP_RATIO[4:0]				18h																																																																					
5Bh	1st	W/R	SHP_THR_H[7:0]								64h																																																																				
5Ch	1st	W/R	SHP_THR_L[7:0]								1Eh																																																																				
Description	<p>This register sets the enhancement level of the sharpness enhancement. This function is able to use when SHP_EN=1</p> <p>SHP_RATIO[4:0]: Adjust the ratio of sharpness enhancement.</p> $Y_{enh} = Y_{org} + (Y_{org} - blur(Y_{org})) \times SHP_RATIO$ <table border="1" style="margin: 10px auto;"> <thead> <tr> <th>SHP_RATIO[4:0]</th> <th>Ratio (Dec)</th> <th>SHP_RATIO[4:0]</th> <th>Ratio (Dec)</th> </tr> </thead> <tbody> <tr><td>00h</td><td>0.0</td><td>10h</td><td>2.0</td></tr> <tr><td>01h</td><td>0.125</td><td>11h</td><td>2.125</td></tr> <tr><td>02h</td><td>0.25</td><td>12h</td><td>2.25</td></tr> <tr><td>03h</td><td>0.375</td><td>13h</td><td>2.375</td></tr> <tr><td>04h</td><td>0.5</td><td>14h</td><td>2.5</td></tr> <tr><td>05h</td><td>0.625</td><td>15h</td><td>2.625</td></tr> <tr><td>06h</td><td>0.75</td><td>16h</td><td>2.75</td></tr> <tr><td>07h</td><td>0.875</td><td>17h</td><td>2.875</td></tr> <tr><td>08h</td><td>1.0</td><td>18h</td><td>3.0</td></tr> <tr><td>09h</td><td>1.125</td><td>19h</td><td>3.125</td></tr> <tr><td>0Ah</td><td>1.25</td><td>1Ah</td><td>3.25</td></tr> <tr><td>0Bh</td><td>1.375</td><td>1Bh</td><td>3.375</td></tr> <tr><td>0Ch</td><td>1.5</td><td>1Ch</td><td>3.5</td></tr> <tr><td>0Dh</td><td>1.625</td><td>1Dh</td><td>3.625</td></tr> <tr><td>0Eh</td><td>1.75</td><td>1Eh</td><td>3.75</td></tr> <tr><td>0Fh</td><td>1.875</td><td>1Fh</td><td>3.875</td></tr> </tbody> </table> <p>SHP_THR_H[7:0]: Define Sharpness enhancement upper bound threshold.</p> <p>SHP_THR_L[7:0]: Define Sharpness enhancement lower bound threshold.</p>											SHP_RATIO[4:0]	Ratio (Dec)	SHP_RATIO[4:0]	Ratio (Dec)	00h	0.0	10h	2.0	01h	0.125	11h	2.125	02h	0.25	12h	2.25	03h	0.375	13h	2.375	04h	0.5	14h	2.5	05h	0.625	15h	2.625	06h	0.75	16h	2.75	07h	0.875	17h	2.875	08h	1.0	18h	3.0	09h	1.125	19h	3.125	0Ah	1.25	1Ah	3.25	0Bh	1.375	1Bh	3.375	0Ch	1.5	1Ch	3.5	0Dh	1.625	1Dh	3.625	0Eh	1.75	1Eh	3.75	0Fh	1.875	1Fh	3.875
	SHP_RATIO[4:0]	Ratio (Dec)	SHP_RATIO[4:0]	Ratio (Dec)																																																																											
	00h	0.0	10h	2.0																																																																											
	01h	0.125	11h	2.125																																																																											
	02h	0.25	12h	2.25																																																																											
	03h	0.375	13h	2.375																																																																											
	04h	0.5	14h	2.5																																																																											
	05h	0.625	15h	2.625																																																																											
	06h	0.75	16h	2.75																																																																											
	07h	0.875	17h	2.875																																																																											
	08h	1.0	18h	3.0																																																																											
	09h	1.125	19h	3.125																																																																											
	0Ah	1.25	1Ah	3.25																																																																											
	0Bh	1.375	1Bh	3.375																																																																											
	0Ch	1.5	1Ch	3.5																																																																											
0Dh	1.625	1Dh	3.625																																																																												
0Eh	1.75	1Eh	3.75																																																																												
0Fh	1.875	1Fh	3.875																																																																												
Restriction	None																																																																														
Register Availability	<table border="1" style="margin: 10px auto;"> <thead> <tr> <th>Status</th> <th>Availability</th> </tr> </thead> <tbody> <tr> <td>Normal Mode On, Idle Mode Off, Sleep Out</td> <td>Yes</td> </tr> <tr> <td>Normal Mode On, Idle Mode On, Sleep Out</td> <td>Yes</td> </tr> <tr> <td>Sleep In</td> <td>Yes</td> </tr> </tbody> </table>											Status	Availability	Normal Mode On, Idle Mode Off, Sleep Out	Yes	Normal Mode On, Idle Mode On, Sleep Out	Yes	Sleep In	Yes																																																												
Status	Availability																																																																														
Normal Mode On, Idle Mode Off, Sleep Out	Yes																																																																														
Normal Mode On, Idle Mode On, Sleep Out	Yes																																																																														
Sleep In	Yes																																																																														
Default	<table border="1" style="margin: 10px auto;"> <thead> <tr> <th>Status</th> <th>Default Value</th> </tr> </thead> <tbody> <tr> <td>Power On Sequence</td> <td>18h_64h_1Eh</td> </tr> <tr> <td>S/W Reset</td> <td>18h_64h_1Eh</td> </tr> <tr> <td>H/W Reset</td> <td>18h_64h_1Eh</td> </tr> </tbody> </table>											Status	Default Value	Power On Sequence	18h_64h_1Eh	S/W Reset	18h_64h_1Eh	H/W Reset	18h_64h_1Eh																																																												
Status	Default Value																																																																														
Power On Sequence	18h_64h_1Eh																																																																														
S/W Reset	18h_64h_1Eh																																																																														
H/W Reset	18h_64h_1Eh																																																																														

5.5.7. IIE Contrast Enhancement Control (60h~66h)

Command Page			Page 2																
Address	Parameter	W/R	D7	D6	D5	D4	D3	D2	D1	D0	Default								
60h	1st	W/R	0	0	CN_00[5:0]						0Eh								
61h	1st	W/R	0	0	CN_01[5:0]						18h								
62h	1st	W/R	0	0	CN_02[5:0]						24h								
63h	1st	W/R	0	0	CN_03[5:0]						28h								
64h	1st	W/R	0	0	CN_04[5:0]						24h								
65h	1st	W/R	0	0	CN_05[5:0]						18h								
66h	1st	W/R	0	0	CN_06[5:0]						0Eh								
Description	<p>This register sets the weight value of the turning point of contrast gain cure. This function is able to use when CN_EN=1</p> <p>CN_00[5:0]: Adjust the weight of S curve ratio of turning point 1. CN_01[5:0]: Adjust the weight of S curve ratio of turning point 2. CN_02[5:0]: Adjust the weight of S curve ratio of turning point 3. CN_03[5:0]: Adjust the weight of S curve ratio of turning point 4. CN_04[5:0]: Adjust the weight of S curve ratio of turning point 5. CN_05[5:0]: Adjust the weight of S curve ratio of turning point 6. CN_06[5:0]: Adjust the weight of S curve ratio of turning point 7.</p> $Y_{enh} = Y_{org} + Y_{delta}$																		
	Restriction	None																	
Register Availability	<table border="1"> <thead> <tr> <th>Status</th> <th>Availability</th> </tr> </thead> <tbody> <tr> <td>Normal Mode On, Idle Mode Off, Sleep Out</td> <td>Yes</td> </tr> <tr> <td>Normal Mode On, Idle Mode On, Sleep Out</td> <td>Yes</td> </tr> <tr> <td>Sleep In</td> <td>Yes</td> </tr> </tbody> </table>											Status	Availability	Normal Mode On, Idle Mode Off, Sleep Out	Yes	Normal Mode On, Idle Mode On, Sleep Out	Yes	Sleep In	Yes
Status	Availability																		
Normal Mode On, Idle Mode Off, Sleep Out	Yes																		
Normal Mode On, Idle Mode On, Sleep Out	Yes																		
Sleep In	Yes																		
Default	<table border="1"> <thead> <tr> <th>Status</th> <th>Default Value</th> </tr> </thead> <tbody> <tr> <td>Power On Sequence</td> <td>0Eh_18h_24h_28h_24h_18h_0Eh</td> </tr> <tr> <td>S/W Reset</td> <td>0Eh_18h_24h_28h_24h_18h_0Eh</td> </tr> <tr> <td>H/W Reset</td> <td>0Eh_18h_24h_28h_24h_18h_0Eh</td> </tr> </tbody> </table>											Status	Default Value	Power On Sequence	0Eh_18h_24h_28h_24h_18h_0Eh	S/W Reset	0Eh_18h_24h_28h_24h_18h_0Eh	H/W Reset	0Eh_18h_24h_28h_24h_18h_0Eh
Status	Default Value																		
Power On Sequence	0Eh_18h_24h_28h_24h_18h_0Eh																		
S/W Reset	0Eh_18h_24h_28h_24h_18h_0Eh																		
H/W Reset	0Eh_18h_24h_28h_24h_18h_0Eh																		

5.5.8. EXTC Command Set Enable Register (FFh)

Command Page			Page 2																																		
Address	Parameter	W/R	D7	D6	D5	D4	D3	D2	D1	D0	Default																										
FFh	1st	W	1	0	0	1	1	0	0	0	98h																										
	2nd	W	1	0	0	0	0	0	0	1	81h																										
	3rd	W	PAGE[7:0]								02h																										
Description	<p>PAGE[7:0]: Set the command page.</p> <table border="1"> <thead> <tr> <th>PAGE[7:0]</th> <th>Command Page</th> </tr> </thead> <tbody> <tr><td>00h</td><td>Page 0</td></tr> <tr><td>01h</td><td>Page 1</td></tr> <tr><td>02h</td><td>Page 2</td></tr> <tr><td>03h</td><td>Page 3</td></tr> <tr><td>04h</td><td>Page 4</td></tr> <tr><td>05h</td><td>Page 5</td></tr> <tr><td>06h</td><td>Page 6</td></tr> <tr><td>07h</td><td>Page 7</td></tr> <tr><td>08h</td><td>Page 8</td></tr> <tr><td>09h</td><td>Page 9</td></tr> <tr><td>0Ah</td><td>Page 10</td></tr> <tr><td>Others</td><td>Reserved</td></tr> </tbody> </table> <p>Set the register, 1st Parameter = 98h, 2nd Parameter = 81h, 3rd Parameter = Page value to enable "Page command set" available</p> <p>See section "5.1 Command Flow".</p>											PAGE[7:0]	Command Page	00h	Page 0	01h	Page 1	02h	Page 2	03h	Page 3	04h	Page 4	05h	Page 5	06h	Page 6	07h	Page 7	08h	Page 8	09h	Page 9	0Ah	Page 10	Others	Reserved
	PAGE[7:0]	Command Page																																			
	00h	Page 0																																			
	01h	Page 1																																			
	02h	Page 2																																			
	03h	Page 3																																			
	04h	Page 4																																			
	05h	Page 5																																			
	06h	Page 6																																			
	07h	Page 7																																			
	08h	Page 8																																			
	09h	Page 9																																			
	0Ah	Page 10																																			
Others	Reserved																																				
Restriction	None																																				
Register Availability	<table border="1"> <thead> <tr> <th>Status</th> <th>Availability</th> </tr> </thead> <tbody> <tr> <td>Normal Mode On, Idle Mode Off, Sleep Out</td> <td>Yes</td> </tr> <tr> <td>Normal Mode On, Idle Mode On, Sleep Out</td> <td>Yes</td> </tr> <tr> <td>Sleep In</td> <td>Yes</td> </tr> </tbody> </table>											Status	Availability	Normal Mode On, Idle Mode Off, Sleep Out	Yes	Normal Mode On, Idle Mode On, Sleep Out	Yes	Sleep In	Yes																		
Status	Availability																																				
Normal Mode On, Idle Mode Off, Sleep Out	Yes																																				
Normal Mode On, Idle Mode On, Sleep Out	Yes																																				
Sleep In	Yes																																				
Default	<table border="1"> <thead> <tr> <th>Status</th> <th>Default Value</th> </tr> </thead> <tbody> <tr> <td>Power On Sequence</td> <td>02h</td> </tr> <tr> <td>S/W Reset</td> <td>02h</td> </tr> <tr> <td>H/W Reset</td> <td>02h</td> </tr> </tbody> </table>											Status	Default Value	Power On Sequence	02h	S/W Reset	02h	H/W Reset	02h																		
Status	Default Value																																				
Power On Sequence	02h																																				
S/W Reset	02h																																				
H/W Reset	02h																																				

5.6. Page 3 Command Description

5.6.1. EXTC Command Set Enable Register (FFh)

Command Page			Page 3																																		
Address	Parameter	W/R	D7	D6	D5	D4	D3	D2	D1	D0	Default																										
FFh	1st	W	1	0	0	1	1	0	0	0	98h																										
	2nd	W	1	0	0	0	0	0	0	1	81h																										
	3rd	W	PAGE[7:0]								03h																										
Description	<p>PAGE[7:0]: Set the command page.</p> <table border="1"> <thead> <tr> <th>PAGE[7:0]</th> <th>Command Page</th> </tr> </thead> <tbody> <tr><td>00h</td><td>Page 0</td></tr> <tr><td>01h</td><td>Page 1</td></tr> <tr><td>02h</td><td>Page 2</td></tr> <tr><td>03h</td><td>Page 3</td></tr> <tr><td>04h</td><td>Page 4</td></tr> <tr><td>05h</td><td>Page 5</td></tr> <tr><td>06h</td><td>Page 6</td></tr> <tr><td>07h</td><td>Page 7</td></tr> <tr><td>08h</td><td>Page 8</td></tr> <tr><td>09h</td><td>Page 9</td></tr> <tr><td>0Ah</td><td>Page 10</td></tr> <tr><td>Others</td><td>Reserved</td></tr> </tbody> </table> <p>Set the register, 1st Parameter = 98h, 2nd Parameter = 81h, 3rd Parameter = Page value to enable "Page command set" available</p> <p>See section "5.1 Command Flow".</p>											PAGE[7:0]	Command Page	00h	Page 0	01h	Page 1	02h	Page 2	03h	Page 3	04h	Page 4	05h	Page 5	06h	Page 6	07h	Page 7	08h	Page 8	09h	Page 9	0Ah	Page 10	Others	Reserved
	PAGE[7:0]	Command Page																																			
	00h	Page 0																																			
	01h	Page 1																																			
	02h	Page 2																																			
	03h	Page 3																																			
	04h	Page 4																																			
	05h	Page 5																																			
	06h	Page 6																																			
	07h	Page 7																																			
	08h	Page 8																																			
	09h	Page 9																																			
	0Ah	Page 10																																			
Others	Reserved																																				
Restriction	None																																				
Register Availability	<table border="1"> <thead> <tr> <th>Status</th> <th>Availability</th> </tr> </thead> <tbody> <tr> <td>Normal Mode On, Idle Mode Off, Sleep Out</td> <td>Yes</td> </tr> <tr> <td>Normal Mode On, Idle Mode On, Sleep Out</td> <td>Yes</td> </tr> <tr> <td>Sleep In</td> <td>Yes</td> </tr> </tbody> </table>											Status	Availability	Normal Mode On, Idle Mode Off, Sleep Out	Yes	Normal Mode On, Idle Mode On, Sleep Out	Yes	Sleep In	Yes																		
Status	Availability																																				
Normal Mode On, Idle Mode Off, Sleep Out	Yes																																				
Normal Mode On, Idle Mode On, Sleep Out	Yes																																				
Sleep In	Yes																																				
Default	<table border="1"> <thead> <tr> <th>Status</th> <th>Default Value</th> </tr> </thead> <tbody> <tr> <td>Power On Sequence</td> <td>03h</td> </tr> <tr> <td>S/W Reset</td> <td>03h</td> </tr> <tr> <td>H/W Reset</td> <td>03h</td> </tr> </tbody> </table>											Status	Default Value	Power On Sequence	03h	S/W Reset	03h	H/W Reset	03h																		
Status	Default Value																																				
Power On Sequence	03h																																				
S/W Reset	03h																																				
H/W Reset	03h																																				

5.7. Page 4 Command Description

5.7.1. DSI Lanes Control (00h)

Command Page			Page 4																
Address	Parameter	W/R	D7	D6	D5	D4	D3	D2	D1	D0	Default								
00h	1st	W/R	MIPI_LANE_SEL	0	0	0	0	0	0	0	80h								
Description		MIPI_LANE_SEL : MIPI DSI lane number selection <i>Note: When use this setting, please reference to chapter 4.1 "DSI System Interface".</i>																	
Restriction		None																	
Register Availability		<table border="1"> <thead> <tr> <th>Status</th> <th>Availability</th> </tr> </thead> <tbody> <tr> <td>Normal Mode On, Idle Mode Off, Sleep Out</td> <td>Yes</td> </tr> <tr> <td>Normal Mode On, Idle Mode On, Sleep Out</td> <td>Yes</td> </tr> <tr> <td>Sleep In</td> <td>Yes</td> </tr> </tbody> </table>										Status	Availability	Normal Mode On, Idle Mode Off, Sleep Out	Yes	Normal Mode On, Idle Mode On, Sleep Out	Yes	Sleep In	Yes
Status	Availability																		
Normal Mode On, Idle Mode Off, Sleep Out	Yes																		
Normal Mode On, Idle Mode On, Sleep Out	Yes																		
Sleep In	Yes																		
Default		<table border="1"> <thead> <tr> <th>Status</th> <th>Default Value</th> </tr> </thead> <tbody> <tr> <td>Power On Sequence</td> <td>80h</td> </tr> <tr> <td>S/W Reset</td> <td>80h</td> </tr> <tr> <td>H/W Reset</td> <td>80h</td> </tr> </tbody> </table>										Status	Default Value	Power On Sequence	80h	S/W Reset	80h	H/W Reset	80h
Status	Default Value																		
Power On Sequence	80h																		
S/W Reset	80h																		
H/W Reset	80h																		

5.7.2. SSC Function (0Bh,0Eh)

Command Page			Page 4																				
Address	Parameter	W/R	D7	D6	D5	D4	D3	D2	D1	D0	Default												
0Bh	1st	W/R	SSC_DIG_EN	SSC_DIG_STEP[2:0]			0	0	0	0	00h												
0Eh	1st	W/R	SSC_DIG_CNT[7:0]								00h												
Description	<p>SSC_DIG_EN : Enable/disable the SSC(Spread Spectrum Clock) function.</p> <p>SSC_DIG_STEP[2:0] : Set SSC parameter.</p> <p>SSC_DIG_CNT[7:0] : Set SSC parameter.</p> <table border="1" style="margin-left: auto; margin-right: auto;"> <thead> <tr> <th>SSC</th> <th>Address 0Bh</th> <th>Address 0Eh</th> </tr> </thead> <tbody> <tr> <td>±1%</td> <td>80h</td> <td>17h</td> </tr> <tr> <td>±2%</td> <td>90h</td> <td>0Bh</td> </tr> <tr> <td>Others</td> <td>Reserved</td> <td>Reserved</td> </tr> </tbody> </table>											SSC	Address 0Bh	Address 0Eh	±1%	80h	17h	±2%	90h	0Bh	Others	Reserved	Reserved
	SSC	Address 0Bh	Address 0Eh																				
±1%	80h	17h																					
±2%	90h	0Bh																					
Others	Reserved	Reserved																					
Restriction	None																						
Register Availability	<table border="1" style="margin-left: auto; margin-right: auto;"> <thead> <tr> <th>Status</th> <th>Availability</th> </tr> </thead> <tbody> <tr> <td>Normal Mode On, Idle Mode Off, Sleep Out</td> <td>Yes</td> </tr> <tr> <td>Normal Mode On, Idle Mode On, Sleep Out</td> <td>Yes</td> </tr> <tr> <td>Sleep In</td> <td>Yes</td> </tr> </tbody> </table>											Status	Availability	Normal Mode On, Idle Mode Off, Sleep Out	Yes	Normal Mode On, Idle Mode On, Sleep Out	Yes	Sleep In	Yes				
Status	Availability																						
Normal Mode On, Idle Mode Off, Sleep Out	Yes																						
Normal Mode On, Idle Mode On, Sleep Out	Yes																						
Sleep In	Yes																						
Default	<table border="1" style="margin-left: auto; margin-right: auto;"> <thead> <tr> <th>Status</th> <th>Default Value</th> </tr> </thead> <tbody> <tr> <td>Power On Sequence</td> <td>00h_00h</td> </tr> <tr> <td>S/W Reset</td> <td>00h_00h</td> </tr> <tr> <td>H/W Reset</td> <td>00h_00h</td> </tr> </tbody> </table>											Status	Default Value	Power On Sequence	00h_00h	S/W Reset	00h_00h	H/W Reset	00h_00h				
Status	Default Value																						
Power On Sequence	00h_00h																						
S/W Reset	00h_00h																						
H/W Reset	00h_00h																						

5.7.3. Charge-Pump Setting (21h)

Command Page			Page 4																
Address	Parameter	W/R	D7	D6	D5	D4	D3	D2	D1	D0	Default								
21h	1st	W/R	DMY_PU MP	0	1	1	0	0	0	0	B0h								
Description	DMY_PUMP : Control the driver behavior when host stop transferring video data.																		
	<table border="1"> <thead> <tr> <th>DMY_PUMP</th> <th>Description</th> </tr> </thead> <tbody> <tr> <td>0</td> <td>Charge-Pump VGH/VGL keep pumping and display shows smallest gamma voltage</td> </tr> <tr> <td>1</td> <td>Charge-Pump VGH/VGL keep pumping</td> </tr> </tbody> </table>											DMY_PUMP	Description	0	Charge-Pump VGH/VGL keep pumping and display shows smallest gamma voltage	1	Charge-Pump VGH/VGL keep pumping		
DMY_PUMP	Description																		
0	Charge-Pump VGH/VGL keep pumping and display shows smallest gamma voltage																		
1	Charge-Pump VGH/VGL keep pumping																		
Restriction	None																		
Register Availability	<table border="1"> <thead> <tr> <th>Status</th> <th>Availability</th> </tr> </thead> <tbody> <tr> <td>Normal Mode On, Idle Mode Off, Sleep Out</td> <td>Yes</td> </tr> <tr> <td>Normal Mode On, Idle Mode On, Sleep Out</td> <td>Yes</td> </tr> <tr> <td>Sleep In</td> <td>Yes</td> </tr> </tbody> </table>											Status	Availability	Normal Mode On, Idle Mode Off, Sleep Out	Yes	Normal Mode On, Idle Mode On, Sleep Out	Yes	Sleep In	Yes
	Status	Availability																	
Normal Mode On, Idle Mode Off, Sleep Out	Yes																		
Normal Mode On, Idle Mode On, Sleep Out	Yes																		
Sleep In	Yes																		
Default	<table border="1"> <thead> <tr> <th>Status</th> <th>Default Value</th> </tr> </thead> <tbody> <tr> <td>Power On Sequence</td> <td>B0h</td> </tr> <tr> <td>S/W Reset</td> <td>B0h</td> </tr> <tr> <td>H/W Reset</td> <td>B0h</td> </tr> </tbody> </table>											Status	Default Value	Power On Sequence	B0h	S/W Reset	B0h	H/W Reset	B0h
	Status	Default Value																	
Power On Sequence	B0h																		
S/W Reset	B0h																		
H/W Reset	B0h																		

5.7.4. Idle Mode Frame Rate (23h)

Command Page			Page 4																
Address	Parameter	W/R	D7	D6	D5	D4	D3	D2	D1	D0	Default								
23h	1st	W/R	RTNB[7:0]								2Dh								
Description	<p>RTNB[7:0]: Used for adjusting frame rate of idle mode by the following rule:</p> <p>One idle frame time = (VACT + VFP + VBP) * (62.5ns * RTNB)</p> <p>VACT (the line number of the LCD) is defined at "5.4.5 Gate Number (2Eh)".</p> <p>VFP and VBP are defined at "5.4.3 Blanking Porch Control (25h~26h)".</p>																		
Restriction	None																		
Register Availability	<table border="1"> <thead> <tr> <th>Status</th> <th>Availability</th> </tr> </thead> <tbody> <tr> <td>Normal Mode On, Idle Mode Off, Sleep Out</td> <td>Yes</td> </tr> <tr> <td>Normal Mode On, Idle Mode On, Sleep Out</td> <td>Yes</td> </tr> <tr> <td>Sleep In</td> <td>Yes</td> </tr> </tbody> </table>											Status	Availability	Normal Mode On, Idle Mode Off, Sleep Out	Yes	Normal Mode On, Idle Mode On, Sleep Out	Yes	Sleep In	Yes
Status	Availability																		
Normal Mode On, Idle Mode Off, Sleep Out	Yes																		
Normal Mode On, Idle Mode On, Sleep Out	Yes																		
Sleep In	Yes																		
Default	<table border="1"> <thead> <tr> <th>Status</th> <th>Default Value</th> </tr> </thead> <tbody> <tr> <td>Power On Sequence</td> <td>2Dh</td> </tr> <tr> <td>S/W Reset</td> <td>2Dh</td> </tr> <tr> <td>H/W Reset</td> <td>2Dh</td> </tr> </tbody> </table>											Status	Default Value	Power On Sequence	2Dh	S/W Reset	2Dh	H/W Reset	2Dh
Status	Default Value																		
Power On Sequence	2Dh																		
S/W Reset	2Dh																		
H/W Reset	2Dh																		

5.7.5. Internal SD Timing Control (26h)

Command Page			Page 4								
Address	Parameter	W/R	D7	D6	D5	D4	D3	D2	D1	D0	Default
26h	1st	W/R	DET_TOLERANCE_OP[3:0]				0	1	1	0	76h
Description	DET_TOLERANCE_OP[3:0]: Control internal SD timing between latch1 load into latch2.										
	DET_TOLERANCE_OP[3:0]				Description						
	0000				62.5ns x 1						
	0001				62.5ns x 2						
						
1111				62.5ns x 16							
Restriction	None										
Register Availability	Status				Availability						
	Normal Mode On, Idle Mode Off, Sleep Out				Yes						
	Normal Mode On, Idle Mode On, Sleep Out				Yes						
	Sleep In				Yes						
Default	Status				Default Value						
	Power On Sequence				76h						
	S/W Reset				76h						
	H/W Reset				76h						

5.7.6. Touch Synchronization Timing Adjust (27h~2Ah)

Command Page			Page 4																								
Address	Parameter	W/R	D7	D6	D5	D4	D3	D2	D1	D0	Default																
27h	1st	W/R	TOUCH_OPT[1:0]		VSOD[1:0]		HSOM[1:0]		HFP_HB_P_OPT	VS_PW_OPT	00h																
28h	1st	W/R	HSOD[7:0]									05h															
29h	1st	W/R	HSOHW[7:0]									19h															
2Ah	1st	W/R	VS_OUT_EN	HS_OUT_EN	VS_OUT_POL	HS_OUT_POL	0	0	STB_EN	0	F0h																
Description			This command controls the synchronization output. This function is able to use when Page1_R29h=01h.																								
			TOUCH_OPT[1:0]: Select the Output Mode of synchronization (time scale: internal T _{OP_CLK})			<table border="1"> <thead> <tr> <th>TOUCH_OPT[1:0]</th> <th>Description</th> </tr> </thead> <tbody> <tr> <td>0h</td> <td>Off</td> </tr> <tr> <td>1h</td> <td>VFP+VBP</td> </tr> <tr> <td>2h</td> <td>Adjustable for VSOUT / HSOUT^(Note 2)</td> </tr> <tr> <td>3h</td> <td>VFP+VBP / HFP+HBP</td> </tr> </tbody> </table>									TOUCH_OPT[1:0]	Description	0h	Off	1h	VFP+VBP	2h	Adjustable for VSOUT / HSOUT ^(Note 2)	3h	VFP+VBP / HFP+HBP			
			TOUCH_OPT[1:0]	Description																							
			0h	Off																							
			1h	VFP+VBP																							
			2h	Adjustable for VSOUT / HSOUT ^(Note 2)																							
			3h	VFP+VBP / HFP+HBP																							
			VSOD[1:0]: Set the VSOUT delay timing (time scale: internal T _{OP_CLK})			<table border="1"> <thead> <tr> <th>VSOD[1:0]</th> <th>Description</th> </tr> </thead> <tbody> <tr> <td>0h</td> <td>0 line (First line of back porch)</td> </tr> <tr> <td>1h</td> <td>1 line</td> </tr> <tr> <td>2h</td> <td>2 line</td> </tr> <tr> <td>3h</td> <td>3 line</td> </tr> </tbody> </table>									VSOD[1:0]	Description	0h	0 line (First line of back porch)	1h	1 line	2h	2 line	3h	3 line			
			VSOD[1:0]	Description																							
			0h	0 line (First line of back porch)																							
1h	1 line																										
2h	2 line																										
3h	3 line																										
HSOM[1:0]: Set the HSOUT active period (time scale: internal T _{OP_CLK})			<table border="1"> <thead> <tr> <th>HSOM[1:0]</th> <th>Description</th> </tr> </thead> <tbody> <tr> <td>0h</td> <td>VACT Period + VFP + VBP</td> </tr> <tr> <td>1h</td> <td>VACT Period</td> </tr> <tr> <td>2h</td> <td>VFP+VBP</td> </tr> <tr> <td>3h</td> <td>Reserved</td> </tr> </tbody> </table>									HSOM[1:0]	Description	0h	VACT Period + VFP + VBP	1h	VACT Period	2h	VFP+VBP	3h	Reserved						
HSOM[1:0]	Description																										
0h	VACT Period + VFP + VBP																										
1h	VACT Period																										
2h	VFP+VBP																										
3h	Reserved																										
HFP_HBP_OPT: Select the output source for HSOUT			<table border="1"> <thead> <tr> <th>HFP_HBP_OPT</th> <th>Description</th> </tr> </thead> <tbody> <tr> <td>0</td> <td>Prebuf-Source</td> </tr> <tr> <td>1</td> <td>HSOUT^(Note 2)</td> </tr> </tbody> </table>									HFP_HBP_OPT	Description	0	Prebuf-Source	1	HSOUT ^(Note 2)										
HFP_HBP_OPT	Description																										
0	Prebuf-Source																										
1	HSOUT ^(Note 2)																										
VS_PW_OPT: Set the pulse width of VSOUT			<table border="1"> <thead> <tr> <th>VS_PW_OPT</th> <th>Description</th> </tr> </thead> <tbody> <tr> <td>0</td> <td>pulse width = 1H</td> </tr> <tr> <td>1</td> <td>During transition from display off to display on : pulse width = 3H During transition from display on to display off : pulse width = 2H Otherwise : pulse width = 1H</td> </tr> </tbody> </table>									VS_PW_OPT	Description	0	pulse width = 1H	1	During transition from display off to display on : pulse width = 3H During transition from display on to display off : pulse width = 2H Otherwise : pulse width = 1H										
VS_PW_OPT	Description																										
0	pulse width = 1H																										
1	During transition from display off to display on : pulse width = 3H During transition from display on to display off : pulse width = 2H Otherwise : pulse width = 1H																										
HSOD[7:0]: Set HSOUT delay timing (time scale: internal T _{OP_CLK})			<table border="1"> <thead> <tr> <th>HSOD[1:0]</th> <th>Description</th> </tr> </thead> <tbody> <tr> <td>0h</td> <td>0clk</td> </tr> <tr> <td>1h</td> <td>1clk</td> </tr> <tr> <td>2h</td> <td>2clk</td> </tr> <tr> <td>:</td> <td>:</td> </tr> <tr> <td>FDh</td> <td>253clk</td> </tr> <tr> <td>FEh</td> <td>254clk</td> </tr> <tr> <td>FFh</td> <td>255clk</td> </tr> </tbody> </table>									HSOD[1:0]	Description	0h	0clk	1h	1clk	2h	2clk	:	:	FDh	253clk	FEh	254clk	FFh	255clk
HSOD[1:0]	Description																										
0h	0clk																										
1h	1clk																										
2h	2clk																										
:	:																										
FDh	253clk																										
FEh	254clk																										
FFh	255clk																										

	<p>HSOHW[7:0]: Set the high width of HSOUT (time scale: internal T_{OP_CLK})</p> <table border="1" data-bbox="611 248 1286 533"> <thead> <tr> <th>HSOHW[1:0]</th> <th>Description</th> </tr> </thead> <tbody> <tr> <td>0h</td> <td>Reserved</td> </tr> <tr> <td>1h</td> <td>1clk</td> </tr> <tr> <td>2h</td> <td>2clk</td> </tr> <tr> <td>:</td> <td>:</td> </tr> <tr> <td>FDh</td> <td>253clk</td> </tr> <tr> <td>FEh</td> <td>254clk</td> </tr> <tr> <td>FFh</td> <td>255clk</td> </tr> </tbody> </table> <p>VS_OUT_EN: VS signal output enable (1: enable, 0: disable)</p> <p>HS_OUT_EN: HS signal output enable (1: enable, 0: disable)</p> <p>VS_OUT_POL: VS signal polarity (1: non-inversion, 0: inversion)</p> <p>HS_OUT_POL: HS signal polarity (1: non-inversion, 0: inversion)</p> <p>STB_EN: touch option</p> <p><i>Note 1: T_{OP_CLK}: 32ns</i></p> <p><i>Note 2: When use this setting, please reference to chapter 17 "Touch Synchronization Signal".</i></p>	HSOHW[1:0]	Description	0h	Reserved	1h	1clk	2h	2clk	:	:	FDh	253clk	FEh	254clk	FFh	255clk
HSOHW[1:0]	Description																
0h	Reserved																
1h	1clk																
2h	2clk																
:	:																
FDh	253clk																
FEh	254clk																
FFh	255clk																
Restriction	None																
Register Availability	<table border="1" data-bbox="608 958 1289 1093"> <thead> <tr> <th>Status</th> <th>Availability</th> </tr> </thead> <tbody> <tr> <td>Normal Mode On, Idle Mode Off, Sleep Out</td> <td>Yes</td> </tr> <tr> <td>Normal Mode On, Idle Mode On, Sleep Out</td> <td>Yes</td> </tr> <tr> <td>Sleep In</td> <td>Yes</td> </tr> </tbody> </table>	Status	Availability	Normal Mode On, Idle Mode Off, Sleep Out	Yes	Normal Mode On, Idle Mode On, Sleep Out	Yes	Sleep In	Yes								
Status	Availability																
Normal Mode On, Idle Mode Off, Sleep Out	Yes																
Normal Mode On, Idle Mode On, Sleep Out	Yes																
Sleep In	Yes																
Default	<table border="1" data-bbox="687 1160 1209 1294"> <thead> <tr> <th>Status</th> <th>Default Value</th> </tr> </thead> <tbody> <tr> <td>Power On Sequence</td> <td>00h_05h_19h_F0h</td> </tr> <tr> <td>S/W Reset</td> <td>00h_05h_19h_F0h</td> </tr> <tr> <td>H/W Reset</td> <td>00h_05h_19h_F0h</td> </tr> </tbody> </table>	Status	Default Value	Power On Sequence	00h_05h_19h_F0h	S/W Reset	00h_05h_19h_F0h	H/W Reset	00h_05h_19h_F0h								
Status	Default Value																
Power On Sequence	00h_05h_19h_F0h																
S/W Reset	00h_05h_19h_F0h																
H/W Reset	00h_05h_19h_F0h																

5.7.7. BIST Mode Function (2Dh,2Fh)

Command Page			Page 4																																										
Address	Parameter	W/R	D7	D6	D5	D4	D3	D2	D1	D0	Default																																		
2Dh	1st	W/R	FRM_PT[7:0]								FFh																																		
2Fh	1st	W/R	0	0	FRM_CYC[1:0]		0	0	0	FRM_EN	00h																																		
Description	<p>FRM_PT[7:0]: Enable/disable the pattern</p> <table border="1"> <thead> <tr> <th>FRM_PT[7:0]</th> <th>Pattern</th> </tr> </thead> <tbody> <tr><td>FRM_PT[0]</td><td>White</td></tr> <tr><td>FRM_PT[1]</td><td>Black</td></tr> <tr><td>FRM_PT[2]</td><td>Red</td></tr> <tr><td>FRM_PT[3]</td><td>Green</td></tr> <tr><td>FRM_PT[4]</td><td>Blue</td></tr> <tr><td>FRM_PT[5]</td><td>Gray128</td></tr> <tr><td>FRM_PT[6]</td><td>Gray127</td></tr> <tr><td>FRM_PT[7]</td><td>V-Color bar</td></tr> </tbody> </table> <p>See also sections: "8 BIST Mode Function "</p> <p>FRM_CYC[1:0]: Set scan cycle of each pattern</p> <table border="1"> <thead> <tr> <th>FRM_CYC[1:0]</th> <th>Description</th> </tr> </thead> <tbody> <tr><td>0h</td><td>64 frames</td></tr> <tr><td>1h</td><td>128 frames</td></tr> <tr><td>2h</td><td>256 frames</td></tr> <tr><td>3h</td><td>512 frames</td></tr> </tbody> </table> <p>FRM_EN: Enable/disable BIST mode function</p> <table border="1"> <thead> <tr> <th>FRM_EN</th> <th>Description</th> </tr> </thead> <tbody> <tr><td>0</td><td>Normal display</td></tr> <tr><td>1</td><td>Enable BIST mode</td></tr> </tbody> </table>											FRM_PT[7:0]	Pattern	FRM_PT[0]	White	FRM_PT[1]	Black	FRM_PT[2]	Red	FRM_PT[3]	Green	FRM_PT[4]	Blue	FRM_PT[5]	Gray128	FRM_PT[6]	Gray127	FRM_PT[7]	V-Color bar	FRM_CYC[1:0]	Description	0h	64 frames	1h	128 frames	2h	256 frames	3h	512 frames	FRM_EN	Description	0	Normal display	1	Enable BIST mode
	FRM_PT[7:0]	Pattern																																											
	FRM_PT[0]	White																																											
	FRM_PT[1]	Black																																											
FRM_PT[2]	Red																																												
FRM_PT[3]	Green																																												
FRM_PT[4]	Blue																																												
FRM_PT[5]	Gray128																																												
FRM_PT[6]	Gray127																																												
FRM_PT[7]	V-Color bar																																												
FRM_CYC[1:0]	Description																																												
0h	64 frames																																												
1h	128 frames																																												
2h	256 frames																																												
3h	512 frames																																												
FRM_EN	Description																																												
0	Normal display																																												
1	Enable BIST mode																																												
Restriction	None																																												
Register Availability	<table border="1"> <thead> <tr> <th>Status</th> <th>Availability</th> </tr> </thead> <tbody> <tr><td>Normal Mode On, Idle Mode Off, Sleep Out</td><td>Yes</td></tr> <tr><td>Normal Mode On, Idle Mode On, Sleep Out</td><td>Yes</td></tr> <tr><td>Sleep In</td><td>Yes</td></tr> </tbody> </table>											Status	Availability	Normal Mode On, Idle Mode Off, Sleep Out	Yes	Normal Mode On, Idle Mode On, Sleep Out	Yes	Sleep In	Yes																										
Status	Availability																																												
Normal Mode On, Idle Mode Off, Sleep Out	Yes																																												
Normal Mode On, Idle Mode On, Sleep Out	Yes																																												
Sleep In	Yes																																												
Default	<table border="1"> <thead> <tr> <th>Status</th> <th>Default Value</th> </tr> </thead> <tbody> <tr><td>Power On Sequence</td><td>FFh_00h</td></tr> <tr><td>S/W Reset</td><td>FFh_00h</td></tr> <tr><td>H/W Reset</td><td>FFh_00h</td></tr> </tbody> </table>											Status	Default Value	Power On Sequence	FFh_00h	S/W Reset	FFh_00h	H/W Reset	FFh_00h																										
Status	Default Value																																												
Power On Sequence	FFh_00h																																												
S/W Reset	FFh_00h																																												
H/W Reset	FFh_00h																																												

5.7.8. Source Timing Setting (35h)

Command Page			Page 4																
Address	Parameter	W/R	D7	D6	D5	D4	D3	D2	D1	D0	Default								
35h	1st	W/R	0	0	0	1	HZ_OPT	1	1	1	17h								
Description	<p>HZ_OPT: Maximum source OP drive time.</p> <table border="1"> <thead> <tr> <th>HZ_OPT</th> <th>Description</th> </tr> </thead> <tbody> <tr> <td>0</td> <td>Disable</td> </tr> <tr> <td>1</td> <td>Enable (Before enable this function , set Page4_R3Ah_D[7]=0)</td> </tr> </tbody> </table>											HZ_OPT	Description	0	Disable	1	Enable (Before enable this function , set Page4_R3Ah_D[7]=0)		
HZ_OPT	Description																		
0	Disable																		
1	Enable (Before enable this function , set Page4_R3Ah_D[7]=0)																		
Restriction	None																		
Register Availability	<table border="1"> <thead> <tr> <th>Status</th> <th>Availability</th> </tr> </thead> <tbody> <tr> <td>Normal Mode On, Idle Mode Off, Sleep Out</td> <td>Yes</td> </tr> <tr> <td>Normal Mode On, Idle Mode On, Sleep Out</td> <td>Yes</td> </tr> <tr> <td>Sleep In</td> <td>Yes</td> </tr> </tbody> </table>											Status	Availability	Normal Mode On, Idle Mode Off, Sleep Out	Yes	Normal Mode On, Idle Mode On, Sleep Out	Yes	Sleep In	Yes
Status	Availability																		
Normal Mode On, Idle Mode Off, Sleep Out	Yes																		
Normal Mode On, Idle Mode On, Sleep Out	Yes																		
Sleep In	Yes																		
Default	<table border="1"> <thead> <tr> <th>Status</th> <th>Default Value</th> </tr> </thead> <tbody> <tr> <td>Power On Sequence</td> <td>17h</td> </tr> <tr> <td>S/W Reset</td> <td>17h</td> </tr> <tr> <td>H/W Reset</td> <td>17h</td> </tr> </tbody> </table>											Status	Default Value	Power On Sequence	17h	S/W Reset	17h	H/W Reset	17h
Status	Default Value																		
Power On Sequence	17h																		
S/W Reset	17h																		
H/W Reset	17h																		

5.7.9. Power Saving Control (3Ah)

Command Page		Page 4																													
Address	Parameter	W/R	D7	D6	D5	D4	D3	D2	D1	D0	Default																				
3Ah	1st	W/R	PS_EN	PCST[6:0]							A4h																				
Description	<p>PS_EN: Source power saving enable</p> <table border="1"> <thead> <tr> <th>PS_EN</th> <th>Description</th> </tr> </thead> <tbody> <tr> <td>0</td> <td>Disable</td> </tr> <tr> <td>1</td> <td>Enable</td> </tr> </tbody> </table> <p>PCST[6:0]: Control power saving period</p> <table border="1"> <thead> <tr> <th>PCST[6:0]</th> <th>Description</th> </tr> </thead> <tbody> <tr> <td>0000000</td> <td>62.5ns x 1</td> </tr> <tr> <td>0000001</td> <td>62.5ns x 2</td> </tr> <tr> <td>0000010</td> <td>62.5ns x 3</td> </tr> <tr> <td>...</td> <td>...</td> </tr> <tr> <td>0100100</td> <td>62.5ns x 37</td> </tr> <tr> <td>Others</td> <td>Inhibited</td> </tr> </tbody> </table>											PS_EN	Description	0	Disable	1	Enable	PCST[6:0]	Description	0000000	62.5ns x 1	0000001	62.5ns x 2	0000010	62.5ns x 3	0100100	62.5ns x 37	Others	Inhibited
	PS_EN	Description																													
0	Disable																														
1	Enable																														
PCST[6:0]	Description																														
0000000	62.5ns x 1																														
0000001	62.5ns x 2																														
0000010	62.5ns x 3																														
...	...																														
0100100	62.5ns x 37																														
Others	Inhibited																														
Restriction	None																														
Register Availability	<table border="1"> <thead> <tr> <th>Status</th> <th>Availability</th> </tr> </thead> <tbody> <tr> <td>Normal Mode On, Idle Mode Off, Sleep Out</td> <td>Yes</td> </tr> <tr> <td>Normal Mode On, Idle Mode On, Sleep Out</td> <td>Yes</td> </tr> <tr> <td>Sleep In</td> <td>Yes</td> </tr> </tbody> </table>											Status	Availability	Normal Mode On, Idle Mode Off, Sleep Out	Yes	Normal Mode On, Idle Mode On, Sleep Out	Yes	Sleep In	Yes												
Status	Availability																														
Normal Mode On, Idle Mode Off, Sleep Out	Yes																														
Normal Mode On, Idle Mode On, Sleep Out	Yes																														
Sleep In	Yes																														
Default	<table border="1"> <thead> <tr> <th>Status</th> <th>Default Value</th> </tr> </thead> <tbody> <tr> <td>Power On Sequence</td> <td>A4h</td> </tr> <tr> <td>S/W Reset</td> <td>A4h</td> </tr> <tr> <td>H/W Reset</td> <td>A4h</td> </tr> </tbody> </table>											Status	Default Value	Power On Sequence	A4h	S/W Reset	A4h	H/W Reset	A4h												
Status	Default Value																														
Power On Sequence	A4h																														
S/W Reset	A4h																														
H/W Reset	A4h																														

5.7.10. Power Control 1 (69h)

Command Page			Page 4																
Address	Parameter	W/R	D7	D6	D5	D4	D3	D2	D1	D0	Default								
69h	1st	W/R	1	CP_VCL_CLP_OPTION_PRE[2:0]			0	1	1	1	D7h								
Description	CP_VCL_CLP_OPTION_PRE[2:0]: Set VCL clamp level.																		
	CP_VCL_CLP_OPTION_PRE[2:0]						VCL clamp level (V)												
	0h						-3.0V												
	1h						-2.9V												
	2h						-2.8V												
	3h						-2.7V												
	4h						-2.6V												
	5h						-2.5V												
	6h						-2.4V												
	7h						-2.3V												
Restriction	None																		
Register Availability	<table border="1"> <thead> <tr> <th>Status</th> <th>Availability</th> </tr> </thead> <tbody> <tr> <td>Normal Mode On, Idle Mode Off, Sleep Out</td> <td>Yes</td> </tr> <tr> <td>Normal Mode On, Idle Mode On, Sleep Out</td> <td>Yes</td> </tr> <tr> <td>Sleep In</td> <td>Yes</td> </tr> </tbody> </table>											Status	Availability	Normal Mode On, Idle Mode Off, Sleep Out	Yes	Normal Mode On, Idle Mode On, Sleep Out	Yes	Sleep In	Yes
Status	Availability																		
Normal Mode On, Idle Mode Off, Sleep Out	Yes																		
Normal Mode On, Idle Mode On, Sleep Out	Yes																		
Sleep In	Yes																		
Default	<table border="1"> <thead> <tr> <th>Status</th> <th>Default Value</th> </tr> </thead> <tbody> <tr> <td>Power On Sequence</td> <td>D7h</td> </tr> <tr> <td>S/W Reset</td> <td>D7h</td> </tr> <tr> <td>H/W Reset</td> <td>D7h</td> </tr> </tbody> </table>											Status	Default Value	Power On Sequence	D7h	S/W Reset	D7h	H/W Reset	D7h
Status	Default Value																		
Power On Sequence	D7h																		
S/W Reset	D7h																		
H/W Reset	D7h																		

5.7.11. Power Control 2 (6Eh)

Command Page		Page 4																																																																		
Address	Parameter	W/R	D7	D6	D5	D4	D3	D2	D1	D0	Default																																																									
6Eh	1st	W/R	0	DI_PWR_REG	REG1_VRH_CP[5:0]						6Ah																																																									
Description	<p>DI_PWR_REG: Select the input power mode.</p> <table border="1"> <thead> <tr> <th>DI_PWR_REG</th> <th>BOOSTM2</th> <th>BOOSTM1</th> <th>BOOSTM0</th> <th>Note</th> </tr> </thead> <tbody> <tr> <td>0</td> <td>0</td> <td>0</td> <td>1</td> <td>Power Mode 2A External VDDI, VSP and VSN (VCI=VSP) ^{Note 1}</td> </tr> <tr> <td>1</td> <td>0</td> <td>0</td> <td>1</td> <td>Power Mode 4 External VDDI, VCI, VSP and VSN</td> </tr> <tr> <td>X</td> <td>0</td> <td>1</td> <td>0</td> <td>Power Mode 3 External VDDI and VCI (ILI4003)</td> </tr> <tr> <td colspan="4">prohibited</td> <td>-</td> </tr> </tbody> </table> <p><i>Note 1: VCI and VSP pads must be connected by external metal path.</i></p> <p>REG1_VRH_CP[5:0]: Set VGH clamp level. (0.18V/step)</p> <table border="1"> <thead> <tr> <th>REG1_VRH_CP[5:0]</th> <th>VGH clamp level (V)</th> </tr> </thead> <tbody> <tr><td>03h</td><td>7.98</td></tr> <tr><td>04h</td><td>8.16</td></tr> <tr><td>05h</td><td>8.34</td></tr> <tr><td>06h</td><td>8.52</td></tr> <tr><td>07h</td><td>8.7</td></tr> <tr><td>08h</td><td>8.88</td></tr> <tr><td>:</td><td>:</td></tr> <tr><td>29h</td><td>14.82</td></tr> <tr><td>2Ah</td><td>15</td></tr> <tr><td>2Bh</td><td>15.18</td></tr> <tr><td>:</td><td>:</td></tr> <tr><td>39h</td><td>17.7</td></tr> <tr><td>3Ah</td><td>17.88</td></tr> <tr><td>3Bh</td><td>18.06</td></tr> <tr><td>Other</td><td>Reserved</td></tr> </tbody> </table>											DI_PWR_REG	BOOSTM2	BOOSTM1	BOOSTM0	Note	0	0	0	1	Power Mode 2A External VDDI, VSP and VSN (VCI=VSP) ^{Note 1}	1	0	0	1	Power Mode 4 External VDDI, VCI, VSP and VSN	X	0	1	0	Power Mode 3 External VDDI and VCI (ILI4003)	prohibited				-	REG1_VRH_CP[5:0]	VGH clamp level (V)	03h	7.98	04h	8.16	05h	8.34	06h	8.52	07h	8.7	08h	8.88	:	:	29h	14.82	2Ah	15	2Bh	15.18	:	:	39h	17.7	3Ah	17.88	3Bh	18.06	Other	Reserved
	DI_PWR_REG	BOOSTM2	BOOSTM1	BOOSTM0	Note																																																															
	0	0	0	1	Power Mode 2A External VDDI, VSP and VSN (VCI=VSP) ^{Note 1}																																																															
	1	0	0	1	Power Mode 4 External VDDI, VCI, VSP and VSN																																																															
	X	0	1	0	Power Mode 3 External VDDI and VCI (ILI4003)																																																															
	prohibited				-																																																															
	REG1_VRH_CP[5:0]	VGH clamp level (V)																																																																		
	03h	7.98																																																																		
	04h	8.16																																																																		
	05h	8.34																																																																		
06h	8.52																																																																			
07h	8.7																																																																			
08h	8.88																																																																			
:	:																																																																			
29h	14.82																																																																			
2Ah	15																																																																			
2Bh	15.18																																																																			
:	:																																																																			
39h	17.7																																																																			
3Ah	17.88																																																																			
3Bh	18.06																																																																			
Other	Reserved																																																																			
Restriction	None																																																																			
Register Availability	<table border="1"> <thead> <tr> <th>Status</th> <th>Availability</th> </tr> </thead> <tbody> <tr> <td>Normal Mode On, Idle Mode Off, Sleep Out</td> <td>Yes</td> </tr> <tr> <td>Normal Mode On, Idle Mode On, Sleep Out</td> <td>Yes</td> </tr> <tr> <td>Sleep In</td> <td>Yes</td> </tr> </tbody> </table>											Status	Availability	Normal Mode On, Idle Mode Off, Sleep Out	Yes	Normal Mode On, Idle Mode On, Sleep Out	Yes	Sleep In	Yes																																																	
Status	Availability																																																																			
Normal Mode On, Idle Mode Off, Sleep Out	Yes																																																																			
Normal Mode On, Idle Mode On, Sleep Out	Yes																																																																			
Sleep In	Yes																																																																			
Default	<table border="1"> <thead> <tr> <th>Status</th> <th>Default Value</th> </tr> </thead> <tbody> <tr> <td>Power On Sequence</td> <td>6Ah</td> </tr> <tr> <td>S/W Reset</td> <td>6Ah</td> </tr> <tr> <td>H/W Reset</td> <td>6Ah</td> </tr> </tbody> </table>											Status	Default Value	Power On Sequence	6Ah	S/W Reset	6Ah	H/W Reset	6Ah																																																	
Status	Default Value																																																																			
Power On Sequence	6Ah																																																																			
S/W Reset	6Ah																																																																			
H/W Reset	6Ah																																																																			

5.7.12. Power Control 3 (6Fh)

Command Page			Page 4																																																																																												
Address	Parameter	W/R	D7	D6	D5	D4	D3	D2	D1	D0	Default																																																																																				
6Fh	1st	W/R	VGLREG_EN_GO	DI_CP_VGH_BH[2:0]			DI_CP_VGL_BL[2:0]			DI_CP_VCL_REG_SEL	34h																																																																																				
Description	<p>VGLREG_EN_GO: Enable/Disable VGL regulator circuit (VGLO1).</p> <table border="1"> <thead> <tr> <th>VGLREG_EN_GO</th> <th>VGL regulator</th> </tr> </thead> <tbody> <tr> <td>0</td> <td>Disable</td> </tr> <tr> <td>1</td> <td>Enable</td> </tr> </tbody> </table> <p>DI_CP_VGH_BH[2:0]: Set the factor used in the step-up circuits for VGH.</p> <p>Select the optimal step-up factor for the operating voltage. To reduce power consumption, set a smaller factor.</p> <table border="1"> <thead> <tr> <th>DI_CP_VGH_BH[2:0]</th> <th>VGH Output (power mode 3, 4)</th> <th>VGH Output (power mode 2A)</th> <th>Flying Capacitor</th> </tr> </thead> <tbody> <tr> <td>0h</td> <td>Reserved</td> <td>Reserved</td> <td>-</td> </tr> <tr> <td>1h</td> <td>2*VSP</td> <td>2*VSP</td> <td>C21P/N + C22P/N (option)</td> </tr> <tr> <td>2h</td> <td>2.5*VSP</td> <td>3*VSP</td> <td>C21P/N + C22P/N (option)</td> </tr> <tr> <td>3h</td> <td>3*VSP</td> <td>3*VSP</td> <td>C21P/N + C22P/N (option)</td> </tr> <tr> <td>4h</td> <td>3.5*VSP</td> <td>4*VSP</td> <td>C21P/N + C22P/N</td> </tr> <tr> <td>5h</td> <td>4*VSP</td> <td>4*VSP</td> <td>C21P/N + C22P/N</td> </tr> <tr> <td>6h</td> <td>4.5*VSP</td> <td>5*VSP</td> <td>C21P/N + C22P/N</td> </tr> <tr> <td>7h</td> <td>5*VSP</td> <td>5*VSP</td> <td>C21P/N + C22P/N</td> </tr> </tbody> </table> <p>DI_CP_VGL_BL[2:0]: Set the factor used in the step-up circuits for VGL. Select the optimal step-up factor for the operating voltage. To reduce power consumption, set a smaller factor.</p> <table border="1"> <thead> <tr> <th>DI_CP_VGL_BL[2:0]</th> <th>VGL Output (power mode 3, 4)</th> <th>VGL Output (power mode 2A)</th> <th>Flying Capacitor</th> </tr> </thead> <tbody> <tr> <td>0h</td> <td>-1.5*VSP</td> <td>-2*VSP</td> <td>C23P/N + C24P/N (option)</td> </tr> <tr> <td>1h</td> <td>-2*VSP</td> <td>-2*VSP</td> <td>C23P/N + C24P/N (option)</td> </tr> <tr> <td>2h</td> <td>-2.5*VSP</td> <td>-3*VSP</td> <td>C23P/N + C24P/N (option)</td> </tr> <tr> <td>3h</td> <td>-3*VSP</td> <td>-3*VSP</td> <td>C23P/N + C24P/N (option)</td> </tr> <tr> <td>4h</td> <td>-3.5*VSP</td> <td>-4*VSP</td> <td>C23P/N + C24P/N</td> </tr> <tr> <td>5h</td> <td>-4*VSP</td> <td>-4*VSP</td> <td>C23P/N + C24P/N</td> </tr> <tr> <td>6h</td> <td>-4.5*VSP</td> <td>-5*VSP</td> <td>C23P/N + C24P/N</td> </tr> <tr> <td>7h</td> <td>-5*VSP</td> <td>-5*VSP</td> <td>C23P/N + C24P/N</td> </tr> </tbody> </table> <p>DI_CP_VCL_REG_SEL: Set VCL power source.</p> <table border="1"> <thead> <tr> <th>DI_CP_VCL_REG_SEL</th> <th>VCL power source</th> </tr> </thead> <tbody> <tr> <td>0</td> <td>Charge-pumping circuit (Connect the C41P/C41N and C42P/C42N capacitor)</td> </tr> <tr> <td>1</td> <td>Regulator circuit (Disconnect the C41P/C41N and C42P/C42N capacitor)</td> </tr> </tbody> </table>											VGLREG_EN_GO	VGL regulator	0	Disable	1	Enable	DI_CP_VGH_BH[2:0]	VGH Output (power mode 3, 4)	VGH Output (power mode 2A)	Flying Capacitor	0h	Reserved	Reserved	-	1h	2*VSP	2*VSP	C21P/N + C22P/N (option)	2h	2.5*VSP	3*VSP	C21P/N + C22P/N (option)	3h	3*VSP	3*VSP	C21P/N + C22P/N (option)	4h	3.5*VSP	4*VSP	C21P/N + C22P/N	5h	4*VSP	4*VSP	C21P/N + C22P/N	6h	4.5*VSP	5*VSP	C21P/N + C22P/N	7h	5*VSP	5*VSP	C21P/N + C22P/N	DI_CP_VGL_BL[2:0]	VGL Output (power mode 3, 4)	VGL Output (power mode 2A)	Flying Capacitor	0h	-1.5*VSP	-2*VSP	C23P/N + C24P/N (option)	1h	-2*VSP	-2*VSP	C23P/N + C24P/N (option)	2h	-2.5*VSP	-3*VSP	C23P/N + C24P/N (option)	3h	-3*VSP	-3*VSP	C23P/N + C24P/N (option)	4h	-3.5*VSP	-4*VSP	C23P/N + C24P/N	5h	-4*VSP	-4*VSP	C23P/N + C24P/N	6h	-4.5*VSP	-5*VSP	C23P/N + C24P/N	7h	-5*VSP	-5*VSP	C23P/N + C24P/N	DI_CP_VCL_REG_SEL	VCL power source	0	Charge-pumping circuit (Connect the C41P/C41N and C42P/C42N capacitor)	1	Regulator circuit (Disconnect the C41P/C41N and C42P/C42N capacitor)
	VGLREG_EN_GO	VGL regulator																																																																																													
	0	Disable																																																																																													
	1	Enable																																																																																													
	DI_CP_VGH_BH[2:0]	VGH Output (power mode 3, 4)	VGH Output (power mode 2A)	Flying Capacitor																																																																																											
	0h	Reserved	Reserved	-																																																																																											
	1h	2*VSP	2*VSP	C21P/N + C22P/N (option)																																																																																											
	2h	2.5*VSP	3*VSP	C21P/N + C22P/N (option)																																																																																											
	3h	3*VSP	3*VSP	C21P/N + C22P/N (option)																																																																																											
	4h	3.5*VSP	4*VSP	C21P/N + C22P/N																																																																																											
5h	4*VSP	4*VSP	C21P/N + C22P/N																																																																																												
6h	4.5*VSP	5*VSP	C21P/N + C22P/N																																																																																												
7h	5*VSP	5*VSP	C21P/N + C22P/N																																																																																												
DI_CP_VGL_BL[2:0]	VGL Output (power mode 3, 4)	VGL Output (power mode 2A)	Flying Capacitor																																																																																												
0h	-1.5*VSP	-2*VSP	C23P/N + C24P/N (option)																																																																																												
1h	-2*VSP	-2*VSP	C23P/N + C24P/N (option)																																																																																												
2h	-2.5*VSP	-3*VSP	C23P/N + C24P/N (option)																																																																																												
3h	-3*VSP	-3*VSP	C23P/N + C24P/N (option)																																																																																												
4h	-3.5*VSP	-4*VSP	C23P/N + C24P/N																																																																																												
5h	-4*VSP	-4*VSP	C23P/N + C24P/N																																																																																												
6h	-4.5*VSP	-5*VSP	C23P/N + C24P/N																																																																																												
7h	-5*VSP	-5*VSP	C23P/N + C24P/N																																																																																												
DI_CP_VCL_REG_SEL	VCL power source																																																																																														
0	Charge-pumping circuit (Connect the C41P/C41N and C42P/C42N capacitor)																																																																																														
1	Regulator circuit (Disconnect the C41P/C41N and C42P/C42N capacitor)																																																																																														
Restriction	None																																																																																														
Register Availability	<table border="1"> <thead> <tr> <th>Status</th> <th>Availability</th> </tr> </thead> <tbody> <tr> <td>Normal Mode On, Idle Mode Off, Sleep Out</td> <td>Yes</td> </tr> <tr> <td>Normal Mode On, Idle Mode On, Sleep Out</td> <td>Yes</td> </tr> <tr> <td>Sleep In</td> <td>Yes</td> </tr> </tbody> </table>											Status	Availability	Normal Mode On, Idle Mode Off, Sleep Out	Yes	Normal Mode On, Idle Mode On, Sleep Out	Yes	Sleep In	Yes																																																																												
Status	Availability																																																																																														
Normal Mode On, Idle Mode Off, Sleep Out	Yes																																																																																														
Normal Mode On, Idle Mode On, Sleep Out	Yes																																																																																														
Sleep In	Yes																																																																																														

Default	<table border="1"><thead><tr><th>Status</th><th>Default Value</th></tr></thead><tbody><tr><td>Power On Sequence</td><td>34h</td></tr><tr><td>S/W Reset</td><td>34h</td></tr><tr><td>H/W Reset</td><td>34h</td></tr></tbody></table>	Status	Default Value	Power On Sequence	34h	S/W Reset	34h	H/W Reset	34h
	Status	Default Value							
	Power On Sequence	34h							
	S/W Reset	34h							
H/W Reset	34h								

5.7.13. VREG1/2 Setting (7Ah)

Command Page			Page 4								
Address	Parameter	W/R	D7	D6	D5	D4	D3	D2	D1	D0	Default
7Ah	1st	W/R	0	0	0	DI_REG_ REG1_EN_ N_CAP	0	0	0	0	00h
Description	DI_REG_REG1_EN_CAP: Using VREG1/2 external caps(1uF) enable										
	DI_REG_REG1_EN_CAP						Description				
	1						IC uses VREG1/2 caps(1uF) at FPC				
0						IC doesn't use VREG1/2 caps(1uF) at FPC					
Restriction	None										
Register Availability	Status						Availability				
	Normal Mode On, Idle Mode Off, Sleep Out						Yes				
	Normal Mode On, Idle Mode On, Sleep Out						Yes				
	Sleep In						Yes				
Default	Status						Default Value				
	Power On Sequence						00h				
	S/W Reset						00h				
	H/W Reset						00h				

5.7.14. LVD Function 1 (87h)

Command Page			Page 4																				
Address	Parameter	W/R	D7	D6	D5	D4	D3	D2	D1	D0	Default												
87h	1st	W/R	DI_LVD_CTL[3:0]				1	0	1	0	BAh												
Description	<p>DI_LVD_CTL[3:0]: The sensitivity adjustment of detecting when battery is removed and power voltage is low.</p> <table border="1"> <thead> <tr> <th>DI_LVD_CTL[3:0]</th> <th>Description</th> </tr> </thead> <tbody> <tr> <td>1111</td> <td>sensitivity high</td> </tr> <tr> <td>1011</td> <td>sensitivity medium</td> </tr> <tr> <td>0010</td> <td>sensitivity low</td> </tr> <tr> <td>0000</td> <td>disable detecting</td> </tr> <tr> <td>Others</td> <td>Inhibited</td> </tr> </tbody> </table>											DI_LVD_CTL[3:0]	Description	1111	sensitivity high	1011	sensitivity medium	0010	sensitivity low	0000	disable detecting	Others	Inhibited
	DI_LVD_CTL[3:0]	Description																					
1111	sensitivity high																						
1011	sensitivity medium																						
0010	sensitivity low																						
0000	disable detecting																						
Others	Inhibited																						
Restriction	None																						
Register Availability	<table border="1"> <thead> <tr> <th>Status</th> <th>Availability</th> </tr> </thead> <tbody> <tr> <td>Normal Mode On, Idle Mode Off, Sleep Out</td> <td>Yes</td> </tr> <tr> <td>Normal Mode On, Idle Mode On, Sleep Out</td> <td>Yes</td> </tr> <tr> <td>Sleep In</td> <td>Yes</td> </tr> </tbody> </table>											Status	Availability	Normal Mode On, Idle Mode Off, Sleep Out	Yes	Normal Mode On, Idle Mode On, Sleep Out	Yes	Sleep In	Yes				
	Status	Availability																					
Normal Mode On, Idle Mode Off, Sleep Out	Yes																						
Normal Mode On, Idle Mode On, Sleep Out	Yes																						
Sleep In	Yes																						
Default	<table border="1"> <thead> <tr> <th>Status</th> <th>Default Value</th> </tr> </thead> <tbody> <tr> <td>Power On Sequence</td> <td>BAh</td> </tr> <tr> <td>S/W Reset</td> <td>BAh</td> </tr> <tr> <td>H/W Reset</td> <td>BAh</td> </tr> </tbody> </table>											Status	Default Value	Power On Sequence	BAh	S/W Reset	BAh	H/W Reset	BAh				
	Status	Default Value																					
Power On Sequence	BAh																						
S/W Reset	BAh																						
H/W Reset	BAh																						

5.7.15. LVD Function 2 (88h)

Command Page			Page 4																
Address	Parameter	W/R	D7	D6	D5	D4	D3	D2	D1	D0	Default								
88h	1st	W/R	DIS_LVD_CHK	0	0	0	1	0	1	1	8Bh								
Description	<p>DIS_LVD_CHK: LVD check function control.</p> <table border="1"> <thead> <tr> <th>DIS_LVD_CHK</th> <th>Description</th> </tr> </thead> <tbody> <tr> <td>0</td> <td>When LVD is detected, IC will directly turn off pump power and go into sleep in sequence</td> </tr> <tr> <td>1</td> <td>When LVD is detected, IC will go into normal power-off/sleep in sequence</td> </tr> </tbody> </table>											DIS_LVD_CHK	Description	0	When LVD is detected, IC will directly turn off pump power and go into sleep in sequence	1	When LVD is detected, IC will go into normal power-off/sleep in sequence		
	DIS_LVD_CHK	Description																	
	0	When LVD is detected, IC will directly turn off pump power and go into sleep in sequence																	
1	When LVD is detected, IC will go into normal power-off/sleep in sequence																		
Restriction	None																		
Register Availability	<table border="1"> <thead> <tr> <th>Status</th> <th>Availability</th> </tr> </thead> <tbody> <tr> <td>Normal Mode On, Idle Mode Off, Sleep Out</td> <td>Yes</td> </tr> <tr> <td>Normal Mode On, Idle Mode On, Sleep Out</td> <td>Yes</td> </tr> <tr> <td>Sleep In</td> <td>Yes</td> </tr> </tbody> </table>											Status	Availability	Normal Mode On, Idle Mode Off, Sleep Out	Yes	Normal Mode On, Idle Mode On, Sleep Out	Yes	Sleep In	Yes
	Status	Availability																	
Normal Mode On, Idle Mode Off, Sleep Out	Yes																		
Normal Mode On, Idle Mode On, Sleep Out	Yes																		
Sleep In	Yes																		
Default	<table border="1"> <thead> <tr> <th>Status</th> <th>Default Value</th> </tr> </thead> <tbody> <tr> <td>Power On Sequence</td> <td>8Bh</td> </tr> <tr> <td>S/W Reset</td> <td>8Bh</td> </tr> <tr> <td>H/W Reset</td> <td>8Bh</td> </tr> </tbody> </table>											Status	Default Value	Power On Sequence	8Bh	S/W Reset	8Bh	H/W Reset	8Bh
Status	Default Value																		
Power On Sequence	8Bh																		
S/W Reset	8Bh																		
H/W Reset	8Bh																		

5.7.16. VCOM Control (8Bh)

Command Page			Page 4																							
Address	Parameter	W/R	D7	D6	D5	D4	D3	D2	D1	D0	Default															
8Bh	1st	W/R	1	1	1	0	DI_VCM _SELO_E N	0	1	1	E3h															
Description		<p>DI_VCM_SELO_EN: Set the VCOM output mode.</p> <table border="1"> <thead> <tr> <th>DI_VCM_SELO_EN</th> <th>GS_PANEL ^{Note}</th> <th>VCOM output mode</th> </tr> </thead> <tbody> <tr> <td>0</td> <td>0</td> <td>Set VCOM level by VCM1[8:0]</td> </tr> <tr> <td>0</td> <td>1</td> <td>Set VCOM level by VCM2[8:0]</td> </tr> <tr> <td>1</td> <td>0</td> <td>VCOM = 0V</td> </tr> <tr> <td>1</td> <td>1</td> <td>VCOM = 0V</td> </tr> </tbody> </table> <p><i>Note: Please reference "5.4.2 Set Panel Operation Mode and Data Complement Setting (22h)"</i></p>										DI_VCM_SELO_EN	GS_PANEL ^{Note}	VCOM output mode	0	0	Set VCOM level by VCM1[8:0]	0	1	Set VCOM level by VCM2[8:0]	1	0	VCOM = 0V	1	1	VCOM = 0V
DI_VCM_SELO_EN	GS_PANEL ^{Note}	VCOM output mode																								
0	0	Set VCOM level by VCM1[8:0]																								
0	1	Set VCOM level by VCM2[8:0]																								
1	0	VCOM = 0V																								
1	1	VCOM = 0V																								
Restriction		None																								
Register Availability		<table border="1"> <thead> <tr> <th>Status</th> <th>Availability</th> </tr> </thead> <tbody> <tr> <td>Normal Mode On, Idle Mode Off, Sleep Out</td> <td>Yes</td> </tr> <tr> <td>Normal Mode On, Idle Mode On, Sleep Out</td> <td>Yes</td> </tr> <tr> <td>Sleep In</td> <td>Yes</td> </tr> </tbody> </table>										Status	Availability	Normal Mode On, Idle Mode Off, Sleep Out	Yes	Normal Mode On, Idle Mode On, Sleep Out	Yes	Sleep In	Yes							
Status	Availability																									
Normal Mode On, Idle Mode Off, Sleep Out	Yes																									
Normal Mode On, Idle Mode On, Sleep Out	Yes																									
Sleep In	Yes																									
Default		<table border="1"> <thead> <tr> <th>Status</th> <th>Default Value</th> </tr> </thead> <tbody> <tr> <td>Power On Sequence</td> <td>E3h</td> </tr> <tr> <td>S/W Reset</td> <td>E3h</td> </tr> <tr> <td>H/W Reset</td> <td>E3h</td> </tr> </tbody> </table>										Status	Default Value	Power On Sequence	E3h	S/W Reset	E3h	H/W Reset	E3h							
Status	Default Value																									
Power On Sequence	E3h																									
S/W Reset	E3h																									
H/W Reset	E3h																									

5.7.17. Power Control 4 (8Ch~8Dh)

Command Page		Page 4									
Address	Parameter	W/R	D7	D6	D5	D4	D3	D2	D1	D0	Default
8Ch	1st	W/R	0	DI_VCOM_REG_VGLREG[6:0]							03h
8Dh	1st	W/R	0	DI_VCOM_CP_VGLCLP[6:0]							14h
Description	DI_VCOM_REG_VGLREG[6:0]: Set VGLO1 voltage adjustment. (0.18V/step)										
			DI_VCOM_REG_VGLREG[6:0]		VGLO1 voltage (V)						
			03h		-6.99						
			04h		-7.17						
			05h		-7.35						
			06h		-7.53						
			07h		-7.71						
			08h		-7.89						
			09h		-8.07						
			0Ah		-8.25						
			0Bh		-8.43						
			0Ch		-8.61						
			0Dh		-8.79						
			0Eh		-8.97						
			0Fh		-9.15						
			10h		-9.33						
			11h		-9.51						
			12h		-9.69						
			13h		-9.87						
			14h		-10.05						
			15h		-10.23						
			:		:						
			3Fh		-17.79						
			40h		-17.97						
			41h		-18.15						
			Others		Reserved						
	DI_VCOM_CP_VGLCLP[6:0]: Set VGL clamp level. (0.18V/step)										
			DI_VCOM_CP_VGLCLP[6:0]		VGL clamp level (V)						
		03h		-6.99							
		04h		-7.17							
		05h		-7.35							
		06h		-7.53							
		07h		-7.71							
		08h		-7.89							
		09h		-8.07							
		0Ah		-8.25							
		0Bh		-8.43							
		0Ch		-8.61							
		0Dh		-8.79							
		0Eh		-8.97							
		0Fh		-9.15							
		10h		-9.33							
		11h		-9.51							
		12h		-9.69							
		13h		-9.87							
		14h		-10.05							

		<table border="1"> <tr><td>15h</td><td>-10.23</td></tr> <tr><td>:</td><td>:</td></tr> <tr><td>3Fh</td><td>-17.79</td></tr> <tr><td>40h</td><td>-17.97</td></tr> <tr><td>41h</td><td>-18.15</td></tr> <tr><td>Others</td><td>Reserved</td></tr> </table>	15h	-10.23	:	:	3Fh	-17.79	40h	-17.97	41h	-18.15	Others	Reserved
15h	-10.23													
:	:													
3Fh	-17.79													
40h	-17.97													
41h	-18.15													
Others	Reserved													
Restriction	None													
Register Availability	<table border="1"> <thead> <tr> <th>Status</th> <th>Availability</th> </tr> </thead> <tbody> <tr> <td>Normal Mode On, Idle Mode Off, Sleep Out</td> <td>Yes</td> </tr> <tr> <td>Normal Mode On, Idle Mode On, Sleep Out</td> <td>Yes</td> </tr> <tr> <td>Sleep In</td> <td>Yes</td> </tr> </tbody> </table>		Status	Availability	Normal Mode On, Idle Mode Off, Sleep Out	Yes	Normal Mode On, Idle Mode On, Sleep Out	Yes	Sleep In	Yes				
Status	Availability													
Normal Mode On, Idle Mode Off, Sleep Out	Yes													
Normal Mode On, Idle Mode On, Sleep Out	Yes													
Sleep In	Yes													
Default	<table border="1"> <thead> <tr> <th>Status</th> <th>Default Value</th> </tr> </thead> <tbody> <tr> <td>Power On Sequence</td> <td>03h_14h</td> </tr> <tr> <td>S/W Reset</td> <td>03h_14h</td> </tr> <tr> <td>H/W Reset</td> <td>03h_14h</td> </tr> </tbody> </table>		Status	Default Value	Power On Sequence	03h_14h	S/W Reset	03h_14h	H/W Reset	03h_14h				
Status	Default Value													
Power On Sequence	03h_14h													
S/W Reset	03h_14h													
H/W Reset	03h_14h													

5.7.18. Reload Gamma Setting (B2h)

Command Page			Page 4																				
Address	Parameter	W/R	D7	D6	D5	D4	D3	D2	D1	D0	Default												
B2h	1st	W/R	RELOAD _GMA_E N	RELOAD _GMA_LI NE8_EN	0	1	0	0	0	1	D1h												
Description	<p>RELOAD_GMA_EN: Gamma setting reload enable when IC operates at sleep-out state.</p> <table border="1"> <thead> <tr> <th>RELOAD_GMA_EN</th> <th>Description</th> </tr> </thead> <tbody> <tr> <td>0</td> <td>Disable</td> </tr> <tr> <td>1</td> <td>Enable</td> </tr> </tbody> </table> <p>RELOAD_GMA_LINE8_EN: Gamma setting reload at the period of 8 line when IC operates at sleep-out state.</p> <table border="1"> <thead> <tr> <th>RELOAD_GMA_LINE8_EN</th> <th>Description</th> </tr> </thead> <tbody> <tr> <td>0</td> <td>Disable</td> </tr> <tr> <td>1</td> <td>Enable</td> </tr> </tbody> </table>											RELOAD_GMA_EN	Description	0	Disable	1	Enable	RELOAD_GMA_LINE8_EN	Description	0	Disable	1	Enable
	RELOAD_GMA_EN	Description																					
0	Disable																						
1	Enable																						
RELOAD_GMA_LINE8_EN	Description																						
0	Disable																						
1	Enable																						
Restriction	None																						
Register Availability	<table border="1"> <thead> <tr> <th>Status</th> <th>Availability</th> </tr> </thead> <tbody> <tr> <td>Normal Mode On, Idle Mode Off, Sleep Out</td> <td>Yes</td> </tr> <tr> <td>Normal Mode On, Idle Mode On, Sleep Out</td> <td>Yes</td> </tr> <tr> <td>Sleep In</td> <td>Yes</td> </tr> </tbody> </table>											Status	Availability	Normal Mode On, Idle Mode Off, Sleep Out	Yes	Normal Mode On, Idle Mode On, Sleep Out	Yes	Sleep In	Yes				
Status	Availability																						
Normal Mode On, Idle Mode Off, Sleep Out	Yes																						
Normal Mode On, Idle Mode On, Sleep Out	Yes																						
Sleep In	Yes																						
Default	<table border="1"> <thead> <tr> <th>Status</th> <th>Default Value</th> </tr> </thead> <tbody> <tr> <td>Power On Sequence</td> <td>D1h</td> </tr> <tr> <td>S/W Reset</td> <td>D1h</td> </tr> <tr> <td>H/W Reset</td> <td>D1h</td> </tr> </tbody> </table>											Status	Default Value	Power On Sequence	D1h	S/W Reset	D1h	H/W Reset	D1h				
Status	Default Value																						
Power On Sequence	D1h																						
S/W Reset	D1h																						
H/W Reset	D1h																						

5.7.19. Gamma Bias Level (B5h)

Command Page			Page 4																		
Address	Parameter	W/R	D7	D6	D5	D4	D3	D2	D1	D0	Default										
B5h	1st	W/R	0	0	0	0	0	DI_GMA_GAP[2:0]			02h										
Description	<p>DI_GMA_GAP[2:0]: Control the gamma bias level.</p> <table border="1"> <thead> <tr> <th>DI_GMA_GAP[2:0]</th> <th>Description</th> </tr> </thead> <tbody> <tr> <td>111</td> <td>High</td> </tr> <tr> <td>110</td> <td>Medium High</td> </tr> <tr> <td>010</td> <td>Default value</td> </tr> <tr> <td>Others</td> <td>inhibited</td> </tr> </tbody> </table>											DI_GMA_GAP[2:0]	Description	111	High	110	Medium High	010	Default value	Others	inhibited
	DI_GMA_GAP[2:0]	Description																			
111	High																				
110	Medium High																				
010	Default value																				
Others	inhibited																				
Restriction	None																				
Register Availability	<table border="1"> <thead> <tr> <th>Status</th> <th>Availability</th> </tr> </thead> <tbody> <tr> <td>Normal Mode On, Idle Mode Off, Sleep Out</td> <td>Yes</td> </tr> <tr> <td>Normal Mode On, Idle Mode On, Sleep Out</td> <td>Yes</td> </tr> <tr> <td>Sleep In</td> <td>Yes</td> </tr> </tbody> </table>											Status	Availability	Normal Mode On, Idle Mode Off, Sleep Out	Yes	Normal Mode On, Idle Mode On, Sleep Out	Yes	Sleep In	Yes		
	Status	Availability																			
Normal Mode On, Idle Mode Off, Sleep Out	Yes																				
Normal Mode On, Idle Mode On, Sleep Out	Yes																				
Sleep In	Yes																				
Default	<table border="1"> <thead> <tr> <th>Status</th> <th>Default Value</th> </tr> </thead> <tbody> <tr> <td>Power On Sequence</td> <td>02h</td> </tr> <tr> <td>S/W Reset</td> <td>02h</td> </tr> <tr> <td>H/W Reset</td> <td>02h</td> </tr> </tbody> </table>											Status	Default Value	Power On Sequence	02h	S/W Reset	02h	H/W Reset	02h		
	Status	Default Value																			
Power On Sequence	02h																				
S/W Reset	02h																				
H/W Reset	02h																				

5.7.20. Temperature Detecting Setting 1 (BBh~C2h)

Command Page			Page 4																																																												
Address	Parameter	W/R	D7	D6	D5	D4	D3	D2	D1	D0	Default																																																				
BBh	1st	W/R	EN_TEM P_PROC ESS	0	CP_VGH_TAP_C[5:0]					1Eh																																																					
BCh	1st	W/R	0	0	CP_VGH_TAP_L[5:0]					1Eh																																																					
BDh	1st	W/R	0	0	CP_VGH_TAP_M[5:0]					1Eh																																																					
BEh	1st	W/R	0	0	CP_VGH_TAP_H[5:0]					1Eh																																																					
BFh	1st	W/R	VCOM_C[7:0]					4Ch																																																							
C0h	1st	W/R	VCOM_L[7:0]					4Ch																																																							
C1h	1st	W/R	VCOM_M[7:0]					4Ch																																																							
C2h	1st	W/R	VCOM_H[7:0]					4Ch																																																							
Description	<p>EN_TEMP_PROCESS / EN_TS: Enable/Disable Temperature Detecting function.</p> <table border="1"> <thead> <tr> <th>EN_TEMP_PROCESS</th> <th>EN_TS</th> <th>Function</th> </tr> </thead> <tbody> <tr> <td>0</td> <td>0</td> <td>Disable</td> </tr> <tr> <td>1</td> <td>1</td> <td>Enable</td> </tr> <tr> <td colspan="2">Other</td> <td>Reserved</td> </tr> </tbody> </table> <p>CP_VGH_TAP_C[5:0]: Set VGH clamp level for Temp_Cold. (0.18V/step) CP_VGH_TAP_L[5:0]: Set VGH clamp level for Temp_Low. (0.18V/step) CP_VGH_TAP_M[5:0]: Set VGH clamp level for Temp_Middle. (0.18V/step) CP_VGH_TAP_H[5:0]: Set VGH clamp level for Temp_High. (0.18V/step)</p> <table border="1"> <thead> <tr> <th>CP_VGH_TAP_C[5:0] CP_VGH_TAP_L[5:0] CP_VGH_TAP_M[5:0] CP_VGH_TAP_H[5:0]</th> <th>VGH clamp level (V)</th> </tr> </thead> <tbody> <tr><td>03h</td><td>7.98</td></tr> <tr><td>04h</td><td>8.16</td></tr> <tr><td>05h</td><td>8.34</td></tr> <tr><td>06h</td><td>8.52</td></tr> <tr><td>07h</td><td>8.7</td></tr> <tr><td>08h</td><td>8.88</td></tr> <tr><td>:</td><td>:</td></tr> <tr><td>28h</td><td>14.64</td></tr> <tr><td>29h</td><td>14.82</td></tr> <tr><td>2Ah</td><td>15</td></tr> <tr><td>2Bh</td><td>15.18</td></tr> <tr><td>2Ch</td><td>15.36</td></tr> <tr><td>:</td><td>:</td></tr> <tr><td>37h</td><td>17.34</td></tr> <tr><td>38h</td><td>17.52</td></tr> <tr><td>39h</td><td>17.7</td></tr> <tr><td>3Ah</td><td>17.88</td></tr> <tr><td>3Bh</td><td>18.06</td></tr> <tr><td>Other</td><td>Reserved</td></tr> </tbody> </table> <p>VCOM_C[8:0]: Set the VCOM level for Temp_Cold. VCOM_L[8:0]: Set the VCOM level for Temp_Low.</p>											EN_TEMP_PROCESS	EN_TS	Function	0	0	Disable	1	1	Enable	Other		Reserved	CP_VGH_TAP_C[5:0] CP_VGH_TAP_L[5:0] CP_VGH_TAP_M[5:0] CP_VGH_TAP_H[5:0]	VGH clamp level (V)	03h	7.98	04h	8.16	05h	8.34	06h	8.52	07h	8.7	08h	8.88	:	:	28h	14.64	29h	14.82	2Ah	15	2Bh	15.18	2Ch	15.36	:	:	37h	17.34	38h	17.52	39h	17.7	3Ah	17.88	3Bh	18.06	Other	Reserved
	EN_TEMP_PROCESS	EN_TS	Function																																																												
	0	0	Disable																																																												
	1	1	Enable																																																												
	Other		Reserved																																																												
	CP_VGH_TAP_C[5:0] CP_VGH_TAP_L[5:0] CP_VGH_TAP_M[5:0] CP_VGH_TAP_H[5:0]	VGH clamp level (V)																																																													
	03h	7.98																																																													
	04h	8.16																																																													
	05h	8.34																																																													
	06h	8.52																																																													
	07h	8.7																																																													
	08h	8.88																																																													
	:	:																																																													
	28h	14.64																																																													
	29h	14.82																																																													
2Ah	15																																																														
2Bh	15.18																																																														
2Ch	15.36																																																														
:	:																																																														
37h	17.34																																																														
38h	17.52																																																														
39h	17.7																																																														
3Ah	17.88																																																														
3Bh	18.06																																																														
Other	Reserved																																																														

	<p>VCOM_M[8:0]: Set the VCOM level for Temp_Middle.</p> <p>VCOM_H[8:0]: Set the VCOM level for Temp_High.</p> <table border="1" data-bbox="679 297 1224 1021"> <thead> <tr> <th>VCOM_C[8:0] VCOM_L[8:0] VCOM_M[8:0] VCOM_H[8:0]</th> <th>VCOM voltage (V)</th> </tr> </thead> <tbody> <tr><td>010h</td><td>-0.204</td></tr> <tr><td>011h</td><td>-0.216</td></tr> <tr><td>012h</td><td>-0.228</td></tr> <tr><td>013h</td><td>-0.24</td></tr> <tr><td>014h</td><td>-0.252</td></tr> <tr><td>015h</td><td>-0.264</td></tr> <tr><td>:</td><td>:</td></tr> <tr><td>07Ah</td><td>-1.476</td></tr> <tr><td>07Bh</td><td>-1.488</td></tr> <tr><td>07Ch</td><td>-1.5</td></tr> <tr><td>:</td><td>:</td></tr> <tr><td>149h</td><td>-3.96</td></tr> <tr><td>14Ah</td><td>-3.972</td></tr> <tr><td>14Bh</td><td>-3.984</td></tr> <tr><td>14Ch</td><td>-3.996</td></tr> <tr><td>14Dh</td><td>-4.008</td></tr> <tr><td>Others</td><td>Reserved</td></tr> </tbody> </table>	VCOM_C[8:0] VCOM_L[8:0] VCOM_M[8:0] VCOM_H[8:0]	VCOM voltage (V)	010h	-0.204	011h	-0.216	012h	-0.228	013h	-0.24	014h	-0.252	015h	-0.264	:	:	07Ah	-1.476	07Bh	-1.488	07Ch	-1.5	:	:	149h	-3.96	14Ah	-3.972	14Bh	-3.984	14Ch	-3.996	14Dh	-4.008	Others	Reserved
VCOM_C[8:0] VCOM_L[8:0] VCOM_M[8:0] VCOM_H[8:0]	VCOM voltage (V)																																				
010h	-0.204																																				
011h	-0.216																																				
012h	-0.228																																				
013h	-0.24																																				
014h	-0.252																																				
015h	-0.264																																				
:	:																																				
07Ah	-1.476																																				
07Bh	-1.488																																				
07Ch	-1.5																																				
:	:																																				
149h	-3.96																																				
14Ah	-3.972																																				
14Bh	-3.984																																				
14Ch	-3.996																																				
14Dh	-4.008																																				
Others	Reserved																																				
Restriction	None																																				
Register Availability	<table border="1" data-bbox="609 1151 1291 1288"> <thead> <tr> <th>Status</th> <th>Availability</th> </tr> </thead> <tbody> <tr> <td>Normal Mode On, Idle Mode Off, Sleep Out</td> <td>Yes</td> </tr> <tr> <td>Normal Mode On, Idle Mode On, Sleep Out</td> <td>Yes</td> </tr> <tr> <td>Sleep In</td> <td>Yes</td> </tr> </tbody> </table>	Status	Availability	Normal Mode On, Idle Mode Off, Sleep Out	Yes	Normal Mode On, Idle Mode On, Sleep Out	Yes	Sleep In	Yes																												
Status	Availability																																				
Normal Mode On, Idle Mode Off, Sleep Out	Yes																																				
Normal Mode On, Idle Mode On, Sleep Out	Yes																																				
Sleep In	Yes																																				
Default	<table border="1" data-bbox="541 1364 1362 1500"> <thead> <tr> <th>Status</th> <th>Default Value</th> </tr> </thead> <tbody> <tr> <td>Power On Sequence</td> <td>1Eh_1Eh_1Eh_1Eh_4Ch_4Ch_4Ch_4Ch</td> </tr> <tr> <td>S/W Reset</td> <td>1Eh_1Eh_1Eh_1Eh_4Ch_4Ch_4Ch_4Ch</td> </tr> <tr> <td>H/W Reset</td> <td>1Eh_1Eh_1Eh_1Eh_4Ch_4Ch_4Ch_4Ch</td> </tr> </tbody> </table>	Status	Default Value	Power On Sequence	1Eh_1Eh_1Eh_1Eh_4Ch_4Ch_4Ch_4Ch	S/W Reset	1Eh_1Eh_1Eh_1Eh_4Ch_4Ch_4Ch_4Ch	H/W Reset	1Eh_1Eh_1Eh_1Eh_4Ch_4Ch_4Ch_4Ch																												
Status	Default Value																																				
Power On Sequence	1Eh_1Eh_1Eh_1Eh_4Ch_4Ch_4Ch_4Ch																																				
S/W Reset	1Eh_1Eh_1Eh_1Eh_4Ch_4Ch_4Ch_4Ch																																				
H/W Reset	1Eh_1Eh_1Eh_1Eh_4Ch_4Ch_4Ch_4Ch																																				

5.7.21. Read VCOM OTP Data (C4h~C7h)

Command Page			Page 4																																												
Address	Parameter	W/R	D7	D6	D5	D4	D3	D2	D1	D0	Default																																				
C4h	1st	R	0	0	0	0	0	0	0	OTP_VCM1[8]	00h																																				
C5h	1st	R	OTP_VCM1[7:0]								7Bh																																				
C6h	1st	R	0	0	0	0	0	0	0	OTP_VCM2[8]	00h																																				
C7h	1st	R	OTP_VCM2[7:0]								7Bh																																				
Description	<p>OTP_VCM1[8:0]: Read the VCOM1 OTP data used for vertical forward scan (GS_PANEL= 1'b0), when NV memory is programmed. (12mV/step)</p> <p>OTP_VCM2[8:0]: Read the VCOM2 OTP data used for vertical backward scan (GS_PANEL= 1'b1), when NV memory is programmed. (12mV/step)</p> <table border="1" style="margin-left: auto; margin-right: auto;"> <thead> <tr> <th>OTP_VCM1[8:0] OTP_VCM2[8:0]</th> <th>VCOM voltage (V)</th> </tr> </thead> <tbody> <tr><td>010h</td><td>-0.204</td></tr> <tr><td>011h</td><td>-0.216</td></tr> <tr><td>012h</td><td>-0.228</td></tr> <tr><td>013h</td><td>-0.24</td></tr> <tr><td>014h</td><td>-0.252</td></tr> <tr><td>015h</td><td>-0.264</td></tr> <tr><td>:</td><td>:</td></tr> <tr><td>07Ah</td><td>-1.476</td></tr> <tr><td>07Bh</td><td>-1.488</td></tr> <tr><td>07Ch</td><td>-1.5</td></tr> <tr><td>:</td><td>:</td></tr> <tr><td>149h</td><td>-3.96</td></tr> <tr><td>14Ah</td><td>-3.972</td></tr> <tr><td>14Bh</td><td>-3.984</td></tr> <tr><td>14Ch</td><td>-3.996</td></tr> <tr><td>14Dh</td><td>-4.008</td></tr> <tr><td>Others</td><td>Reserved</td></tr> </tbody> </table> <p style="text-align: center;"><i>Note: VCOM ≥ VSN + 0.5V</i></p>											OTP_VCM1[8:0] OTP_VCM2[8:0]	VCOM voltage (V)	010h	-0.204	011h	-0.216	012h	-0.228	013h	-0.24	014h	-0.252	015h	-0.264	:	:	07Ah	-1.476	07Bh	-1.488	07Ch	-1.5	:	:	149h	-3.96	14Ah	-3.972	14Bh	-3.984	14Ch	-3.996	14Dh	-4.008	Others	Reserved
	OTP_VCM1[8:0] OTP_VCM2[8:0]	VCOM voltage (V)																																													
	010h	-0.204																																													
	011h	-0.216																																													
	012h	-0.228																																													
	013h	-0.24																																													
	014h	-0.252																																													
	015h	-0.264																																													
	:	:																																													
	07Ah	-1.476																																													
	07Bh	-1.488																																													
	07Ch	-1.5																																													
	:	:																																													
	149h	-3.96																																													
	14Ah	-3.972																																													
14Bh	-3.984																																														
14Ch	-3.996																																														
14Dh	-4.008																																														
Others	Reserved																																														
Restriction	None																																														
Register Availability	<table border="1" style="margin-left: auto; margin-right: auto;"> <thead> <tr> <th>Status</th> <th>Availability</th> </tr> </thead> <tbody> <tr> <td>Normal Mode On, Idle Mode Off, Sleep Out</td> <td>Yes</td> </tr> <tr> <td>Normal Mode On, Idle Mode On, Sleep Out</td> <td>Yes</td> </tr> <tr> <td>Sleep In</td> <td>Yes</td> </tr> </tbody> </table>											Status	Availability	Normal Mode On, Idle Mode Off, Sleep Out	Yes	Normal Mode On, Idle Mode On, Sleep Out	Yes	Sleep In	Yes																												
Status	Availability																																														
Normal Mode On, Idle Mode Off, Sleep Out	Yes																																														
Normal Mode On, Idle Mode On, Sleep Out	Yes																																														
Sleep In	Yes																																														
Default	<table border="1" style="margin-left: auto; margin-right: auto;"> <thead> <tr> <th>Status</th> <th>Default Value</th> </tr> </thead> <tbody> <tr> <td>Power On Sequence</td> <td>00h_7Bh_00h_7Bh</td> </tr> <tr> <td>S/W Res t</td> <td>00h_7Bh_00h_7Bh</td> </tr> <tr> <td>H/W Reset</td> <td>00h_7Bh_00h_7Bh</td> </tr> </tbody> </table>											Status	Default Value	Power On Sequence	00h_7Bh_00h_7Bh	S/W Res t	00h_7Bh_00h_7Bh	H/W Reset	00h_7Bh_00h_7Bh																												
Status	Default Value																																														
Power On Sequence	00h_7Bh_00h_7Bh																																														
S/W Res t	00h_7Bh_00h_7Bh																																														
H/W Reset	00h_7Bh_00h_7Bh																																														

5.7.22. Temperature Detecting Setting 2 (C8h~CEh)

Command Page			Page 4																
Address	Parameter	W/R	D7	D6	D5	D4	D3	D2	D1	D0	Default								
C8h	1st	W/R	TS_TH0[7:0]									00h							
C9h	1st	W/R	TS_TH1[7:0]									00h							
CAh	1st	W/R	TS_TH2[7:0]									00h							
CBh	1st	W/R	TS_TH3[7:0]									00h							
CCh	1st	W/R	TS_TH0[9:8]		TS_TH1[9:8]		TS_TH2[9:8]		TS_TH3[9:8]		00h								
CDh	1st	W/R	TS_DEBT_OPT[3:0]				TS_HYST_OPT[3:0]				02h								
CEh	1st	W/R	EN_TS	VCOM_C[8]	VCOM_L[8]	VCOM_M[8]	VCOM_H[8]	1	0	0	04h								
Description	<p>TS_TH0[9:0]: Set the temperature detecting range threshold for Temp_Cold.</p> <p>TS_TH1[9:0]: Set the temperature detecting range threshold for Temp_Low.</p> <p>TS_TH2[9:0]: Set the temperature detecting range threshold for Temp_Middle.</p> <p>TS_TH3[9:0]: Set the temperature detecting range threshold for Temp_High.</p> <p>TS_DEBT_OPT[3:0]: Set the de-bounce of temperature detecting range.</p> <p>TS_HYST_OPT[3:0]: Set the hysteresis of temperature detecting range.</p>																		
Restriction	None																		
Register Availability	<table border="1"> <thead> <tr> <th>Status</th> <th>Availability</th> </tr> </thead> <tbody> <tr> <td>Normal Mode On, Idle Mode Off, Sleep Out</td> <td>Yes</td> </tr> <tr> <td>Normal Mode On, Idle Mode On, Sleep Out</td> <td>Yes</td> </tr> <tr> <td>Sleep In</td> <td>Yes</td> </tr> </tbody> </table>											Status	Availability	Normal Mode On, Idle Mode Off, Sleep Out	Yes	Normal Mode On, Idle Mode On, Sleep Out	Yes	Sleep In	Yes
Status	Availability																		
Normal Mode On, Idle Mode Off, Sleep Out	Yes																		
Normal Mode On, Idle Mode On, Sleep Out	Yes																		
Sleep In	Yes																		
Default	<table border="1"> <thead> <tr> <th>Status</th> <th>Default Value</th> </tr> </thead> <tbody> <tr> <td>Power On Sequence</td> <td>00h_00h_00h_00h_00h_02h_04h</td> </tr> <tr> <td>S/W Reset</td> <td>00h_00h_00h_00h_00h_02h_04h</td> </tr> <tr> <td>H/W Reset</td> <td>00h_00h_00h_00h_00h_02h_04h</td> </tr> </tbody> </table>											Status	Default Value	Power On Sequence	00h_00h_00h_00h_00h_02h_04h	S/W Reset	00h_00h_00h_00h_00h_02h_04h	H/W Reset	00h_00h_00h_00h_00h_02h_04h
Status	Default Value																		
Power On Sequence	00h_00h_00h_00h_00h_02h_04h																		
S/W Reset	00h_00h_00h_00h_00h_02h_04h																		
H/W Reset	00h_00h_00h_00h_00h_02h_04h																		

5.7.23. OTP Control (D7h)

Command Page		Page 4																		
Address	Parameter	W/R	D7	D6	D5	D4	D3	D2	D1	D0	Default									
D7h	1st	W/R	0	0	0	OTP_PA TH	PROG_SEL[1:0]		0	0	1Ch									
Description	OTP_PATH: <table border="1" style="margin-left: 40px;"> <thead> <tr> <th>OTP_PATH</th> <th>Description</th> </tr> </thead> <tbody> <tr> <td>0</td> <td>Internal VGH Programming</td> </tr> <tr> <td>1</td> <td>External MTP_PWR Programming</td> </tr> </tbody> </table>											OTP_PATH	Description	0	Internal VGH Programming	1	External MTP_PWR Programming			
	OTP_PATH	Description																		
0	Internal VGH Programming																			
1	External MTP_PWR Programming																			
PROG_SEL[1:0]: <table border="1" style="margin-left: 40px;"> <thead> <tr> <th>PROG_SEL[1:0]</th> <th>Description</th> </tr> </thead> <tbody> <tr> <td>0h</td> <td>Inhibited</td> </tr> <tr> <td>1h</td> <td>Internal Programming Setting (Best Setting)</td> </tr> <tr> <td>2h</td> <td>Inhibited</td> </tr> <tr> <td>3h</td> <td>Internal Programming Setting (Default)</td> </tr> </tbody> </table>											PROG_SEL[1:0]	Description	0h	Inhibited	1h	Internal Programming Setting (Best Setting)	2h	Inhibited	3h	Internal Programming Setting (Default)
PROG_SEL[1:0]	Description																			
0h	Inhibited																			
1h	Internal Programming Setting (Best Setting)																			
2h	Inhibited																			
3h	Internal Programming Setting (Default)																			
Restriction	None																			
Register Availability	<table border="1" style="margin-left: 40px;"> <thead> <tr> <th>Status</th> <th>Availability</th> </tr> </thead> <tbody> <tr> <td>Normal Mode On, Idle Mode Off, Sleep Out</td> <td>Yes</td> </tr> <tr> <td>Normal Mode On, Idle Mode On, Sleep Out</td> <td>Yes</td> </tr> <tr> <td>Sleep In</td> <td>Yes</td> </tr> </tbody> </table>											Status	Availability	Normal Mode On, Idle Mode Off, Sleep Out	Yes	Normal Mode On, Idle Mode On, Sleep Out	Yes	Sleep In	Yes	
Status	Availability																			
Normal Mode On, Idle Mode Off, Sleep Out	Yes																			
Normal Mode On, Idle Mode On, Sleep Out	Yes																			
Sleep In	Yes																			
Default	<table border="1" style="margin-left: 40px;"> <thead> <tr> <th>Status</th> <th>Default Value</th> </tr> </thead> <tbody> <tr> <td>Power On Sequence</td> <td>1Ch</td> </tr> <tr> <td>S/W Reset</td> <td>1Ch</td> </tr> <tr> <td>H/W Reset</td> <td>1Ch</td> </tr> </tbody> </table>											Status	Default Value	Power On Sequence	1Ch	S/W Reset	1Ch	H/W Reset	1Ch	
Status	Default Value																			
Power On Sequence	1Ch																			
S/W Reset	1Ch																			
H/W Reset	1Ch																			

5.7.24. EXTC Command Set Enable Register (FFh)

Command Page			Page 4																																		
Address	Parameter	W/R	D7	D6	D5	D4	D3	D2	D1	D0	Default																										
FFh	1st	W	1	0	0	1	1	0	0	0	98h																										
	2nd	W	1	0	0	0	0	0	0	1	81h																										
	3rd	W	PAGE[7:0]								04h																										
Description	<p>PAGE[7:0]: Set the command page.</p> <table border="1"> <thead> <tr> <th>PAGE[7:0]</th> <th>Command Page</th> </tr> </thead> <tbody> <tr><td>00h</td><td>Page 0</td></tr> <tr><td>01h</td><td>Page 1</td></tr> <tr><td>02h</td><td>Page 2</td></tr> <tr><td>03h</td><td>Page 3</td></tr> <tr><td>04h</td><td>Page 4</td></tr> <tr><td>05h</td><td>Page 5</td></tr> <tr><td>06h</td><td>Page 6</td></tr> <tr><td>07h</td><td>Page 7</td></tr> <tr><td>08h</td><td>Page 8</td></tr> <tr><td>09h</td><td>Page 9</td></tr> <tr><td>0Ah</td><td>Page 10</td></tr> <tr><td>Others</td><td>Reserved</td></tr> </tbody> </table> <p>Set the register, 1st Parameter = 98h, 2nd Parameter = 81h, 3rd Parameter = Page value to enable "Page command set" available</p> <p>See section "5.1 Command Flow".</p>											PAGE[7:0]	Command Page	00h	Page 0	01h	Page 1	02h	Page 2	03h	Page 3	04h	Page 4	05h	Page 5	06h	Page 6	07h	Page 7	08h	Page 8	09h	Page 9	0Ah	Page 10	Others	Reserved
	PAGE[7:0]	Command Page																																			
	00h	Page 0																																			
	01h	Page 1																																			
	02h	Page 2																																			
	03h	Page 3																																			
	04h	Page 4																																			
	05h	Page 5																																			
	06h	Page 6																																			
	07h	Page 7																																			
	08h	Page 8																																			
	09h	Page 9																																			
	0Ah	Page 10																																			
Others	Reserved																																				
Restriction	None																																				
Register Availability	<table border="1"> <thead> <tr> <th>Status</th> <th>Availability</th> </tr> </thead> <tbody> <tr> <td>Normal Mode On, Idle Mode Off, Sleep Out</td> <td>Yes</td> </tr> <tr> <td>Normal Mode On, Idle Mode On, Sleep Out</td> <td>Yes</td> </tr> <tr> <td>Sleep In</td> <td>Yes</td> </tr> </tbody> </table>											Status	Availability	Normal Mode On, Idle Mode Off, Sleep Out	Yes	Normal Mode On, Idle Mode On, Sleep Out	Yes	Sleep In	Yes																		
Status	Availability																																				
Normal Mode On, Idle Mode Off, Sleep Out	Yes																																				
Normal Mode On, Idle Mode On, Sleep Out	Yes																																				
Sleep In	Yes																																				
Default	<table border="1"> <thead> <tr> <th>Status</th> <th>Default Value</th> </tr> </thead> <tbody> <tr> <td>Power On Sequence</td> <td>04h</td> </tr> <tr> <td>S/W Reset</td> <td>04h</td> </tr> <tr> <td>H/W Reset</td> <td>04h</td> </tr> </tbody> </table>											Status	Default Value	Power On Sequence	04h	S/W Reset	04h	H/W Reset	04h																		
Status	Default Value																																				
Power On Sequence	04h																																				
S/W Reset	04h																																				
H/W Reset	04h																																				

5.8. Page 5 Command Description

5.8.1. Fine Digital Gamma Control 1 (00h~7Fh)

Command Page			Page 5								
Address	Parameter	W/R	D7	D6	D5	D4	D3	D2	D1	D0	Default
00h	1st	W									00h
01h	1st	W									00h
02h	1st	W									00h
03h	1st	W									00h
04h	1st	W									00h
05h	1st	W									00h
:	1st	W									00h
7Ah	1st	W									00h
7Bh	1st	W									00h
7Ch	1st	W									00h
7Dh	1st	W									00h
7Eh	1st	W									00h
7Fh	1st	W									00h

Description	<p>RDINx[7:0]: Digital Gamma Macro-adjustment registers for red gamma curve.</p> <p>Setting Digital Gamma Control 1</p> <table border="1"> <thead> <tr> <th>Register Address</th> <th>1st parameter Device code 1</th> <th>2nd parameter Device code 2</th> <th>3rd parameter Page_select</th> </tr> </thead> <tbody> <tr> <td>FFh</td> <td>98h</td> <td>81h</td> <td>05h</td> </tr> </tbody> </table> <p>Set register 00h=XXh XXh = Digital Gamma adjustment</p> <p>Case 1 (The first time to set Digital Gamma Control)</p> <p>Command Sequence (by order) Set register 01h = XXh Set register 02h = XXh . Set register 7Dh = XXh Set register 7Eh = XXh XXh = Digital Gamma adjustment</p> <table border="1"> <thead> <tr> <th>Register Address</th> <th>1st parameter Device code 1</th> <th>2nd parameter Device code 2</th> <th>3rd parameter Page_select</th> </tr> </thead> <tbody> <tr> <td>FFh</td> <td>98h</td> <td>81h</td> <td>ZZh</td> </tr> </tbody> </table> <p>ZZ=Other Page Number</p> <p>Case 2 Modify any one command (01h~7Eh) example: modify register 35h = yyh yyh = Digital Gamma adjustment (Other registers still keep original value)</p> <p>Set register 7Fh=XXh XXh = Digital Gamma adjustment</p> <p>Digital Gamma Control 1 Setting finished</p> <p>(Return to Case 2 Set Digital Gamma Control Flow)</p>	Register Address	1st parameter Device code 1	2nd parameter Device code 2	3rd parameter Page_select	FFh	98h	81h	05h	Register Address	1st parameter Device code 1	2nd parameter Device code 2	3rd parameter Page_select	FFh	98h	81h	ZZh
	Register Address	1st parameter Device code 1	2nd parameter Device code 2	3rd parameter Page_select													
FFh	98h	81h	05h														
Register Address	1st parameter Device code 1	2nd parameter Device code 2	3rd parameter Page_select														
FFh	98h	81h	ZZh														
Restriction	None																

<p>Register Availability</p>	<table border="1"> <thead> <tr> <th>Status</th> <th>Availability</th> </tr> </thead> <tbody> <tr> <td>Normal Mode On, Idle Mode Off, Sleep Out</td> <td>Yes</td> </tr> <tr> <td>Normal Mode On, Idle Mode On, Sleep Out</td> <td>Yes</td> </tr> <tr> <td>Sleep In</td> <td>Yes</td> </tr> </tbody> </table>	Status	Availability	Normal Mode On, Idle Mode Off, Sleep Out	Yes	Normal Mode On, Idle Mode On, Sleep Out	Yes	Sleep In	Yes
Status	Availability								
Normal Mode On, Idle Mode Off, Sleep Out	Yes								
Normal Mode On, Idle Mode On, Sleep Out	Yes								
Sleep In	Yes								
<p>Default</p>	<table border="1"> <thead> <tr> <th>Status</th> <th>Default Value</th> </tr> </thead> <tbody> <tr> <td>Power On Sequence</td> <td>00h_00h...00h_00h</td> </tr> <tr> <td>S/W Reset</td> <td>00h_00h...00h_00h</td> </tr> <tr> <td>H/W Reset</td> <td>00h_00h...00h_00h</td> </tr> </tbody> </table>	Status	Default Value	Power On Sequence	00h_00h...00h_00h	S/W Reset	00h_00h...00h_00h	H/W Reset	00h_00h...00h_00h
Status	Default Value								
Power On Sequence	00h_00h...00h_00h								
S/W Reset	00h_00h...00h_00h								
H/W Reset	00h_00h...00h_00h								

5.8.2. Digital 3 Gamma Enable (80h)

Command Page			Page 5																
Address	Parameter	W/R	D7	D6	D5	D4	D3	D2	D1	D0	Default								
80h	1st	W/R	0	0	0	0	0	0	0	EN_3G	00h								
Description	En_3G: 0 : digital 3 gamma disable 1 : digital 3 gamma enable																		
Restriction	None																		
Register Availability	<table border="1"> <thead> <tr> <th>Status</th> <th>Availability</th> </tr> </thead> <tbody> <tr> <td>Normal Mode On, Idle Mode Off, Sleep Out</td> <td>Yes</td> </tr> <tr> <td>Normal Mode On, Idle Mode On, Sleep Out</td> <td>Yes</td> </tr> <tr> <td>Sleep In</td> <td>Yes</td> </tr> </tbody> </table>											Status	Availability	Normal Mode On, Idle Mode Off, Sleep Out	Yes	Normal Mode On, Idle Mode On, Sleep Out	Yes	Sleep In	Yes
Status	Availability																		
Normal Mode On, Idle Mode Off, Sleep Out	Yes																		
Normal Mode On, Idle Mode On, Sleep Out	Yes																		
Sleep In	Yes																		
Default	<table border="1"> <thead> <tr> <th>Status</th> <th>Default Value (Before OTP program)</th> </tr> </thead> <tbody> <tr> <td>Power On Sequence</td> <td>00h</td> </tr> <tr> <td>S/W Reset</td> <td>00h</td> </tr> <tr> <td>H/W Reset</td> <td>00h</td> </tr> </tbody> </table>											Status	Default Value (Before OTP program)	Power On Sequence	00h	S/W Reset	00h	H/W Reset	00h
Status	Default Value (Before OTP program)																		
Power On Sequence	00h																		
S/W Reset	00h																		
H/W Reset	00h																		

5.8.3. EXTC Command Set Enable Register (FFh)

Command Page			Page 5																																		
Address	Parameter	W/R	D7	D6	D5	D4	D3	D2	D1	D0	Default																										
FFh	1st	W	1	0	0	1	1	0	0	0	98h																										
	2nd	W	1	0	0	0	0	0	0	1	81h																										
	3rd	W	PAGE[7:0]								05h																										
Description	<p>PAGE[7:0]: Set the command page.</p> <table border="1"> <thead> <tr> <th>PAGE[7:0]</th> <th>Command Page</th> </tr> </thead> <tbody> <tr><td>00h</td><td>Page 0</td></tr> <tr><td>01h</td><td>Page 1</td></tr> <tr><td>02h</td><td>Page 2</td></tr> <tr><td>03h</td><td>Page 3</td></tr> <tr><td>04h</td><td>Page 4</td></tr> <tr><td>05h</td><td>Page 5</td></tr> <tr><td>06h</td><td>Page 6</td></tr> <tr><td>07h</td><td>Page 7</td></tr> <tr><td>08h</td><td>Page 8</td></tr> <tr><td>09h</td><td>Page 9</td></tr> <tr><td>0Ah</td><td>Page 10</td></tr> <tr><td>Others</td><td>Reserved</td></tr> </tbody> </table> <p>Set the register, 1st Parameter = 98h, 2nd Parameter = 81h, 3rd Parameter = Page value to enable "Page command set" available</p> <p>See section "5.1 Command Flow".</p>											PAGE[7:0]	Command Page	00h	Page 0	01h	Page 1	02h	Page 2	03h	Page 3	04h	Page 4	05h	Page 5	06h	Page 6	07h	Page 7	08h	Page 8	09h	Page 9	0Ah	Page 10	Others	Reserved
	PAGE[7:0]	Command Page																																			
	00h	Page 0																																			
	01h	Page 1																																			
	02h	Page 2																																			
	03h	Page 3																																			
	04h	Page 4																																			
	05h	Page 5																																			
	06h	Page 6																																			
	07h	Page 7																																			
	08h	Page 8																																			
	09h	Page 9																																			
	0Ah	Page 10																																			
Others	Reserved																																				
Restriction	None																																				
Register Availability	<table border="1"> <thead> <tr> <th>Status</th> <th>Availability</th> </tr> </thead> <tbody> <tr> <td>Normal Mode On, Idle Mode Off, Sleep Out</td> <td>Yes</td> </tr> <tr> <td>Normal Mode On, Idle Mode On, Sleep Out</td> <td>Yes</td> </tr> <tr> <td>Sleep In</td> <td>Yes</td> </tr> </tbody> </table>											Status	Availability	Normal Mode On, Idle Mode Off, Sleep Out	Yes	Normal Mode On, Idle Mode On, Sleep Out	Yes	Sleep In	Yes																		
Status	Availability																																				
Normal Mode On, Idle Mode Off, Sleep Out	Yes																																				
Normal Mode On, Idle Mode On, Sleep Out	Yes																																				
Sleep In	Yes																																				
Default	<table border="1"> <thead> <tr> <th>Status</th> <th>Default Value</th> </tr> </thead> <tbody> <tr> <td>Power On Sequence</td> <td>05h</td> </tr> <tr> <td>S/W Reset</td> <td>05h</td> </tr> <tr> <td>H/W Reset</td> <td>05h</td> </tr> </tbody> </table>											Status	Default Value	Power On Sequence	05h	S/W Reset	05h	H/W Reset	05h																		
Status	Default Value																																				
Power On Sequence	05h																																				
S/W Reset	05h																																				
H/W Reset	05h																																				

5.9. Page 6 Command Description

5.9.1. Fine Digital Gamma Control 2 (00h~7Fh)

Command Page			Page 6								
Address	Parameter	W/R	D7	D6	D5	D4	D3	D2	D1	D0	Default
00h	1st	W	RDIN128[7:0]								00h
01h	1st	W	RDIN129[7:0]								00h
02h	1st	W	RDIN130[7:0]								00h
03h	1st	W	RDIN131[7:0]								00h
04h	1st	W	RDIN132[7:0]								00h
05h	1st	W	RDIN133[7:0]								00h
:	1st	W	:								00h
7Ah	1st	W	RDIN250[7:0]								00h
7Bh	1st	W	RDIN251[7:0]								00h
7Ch	1st	W	RDIN252[7:0]								00h
7Dh	1st	W	RDIN253[7:0]								00h
7Eh	1st	W	RDIN254[7:0]								00h
7Fh	1st	W	RDIN255[7:0]								00h

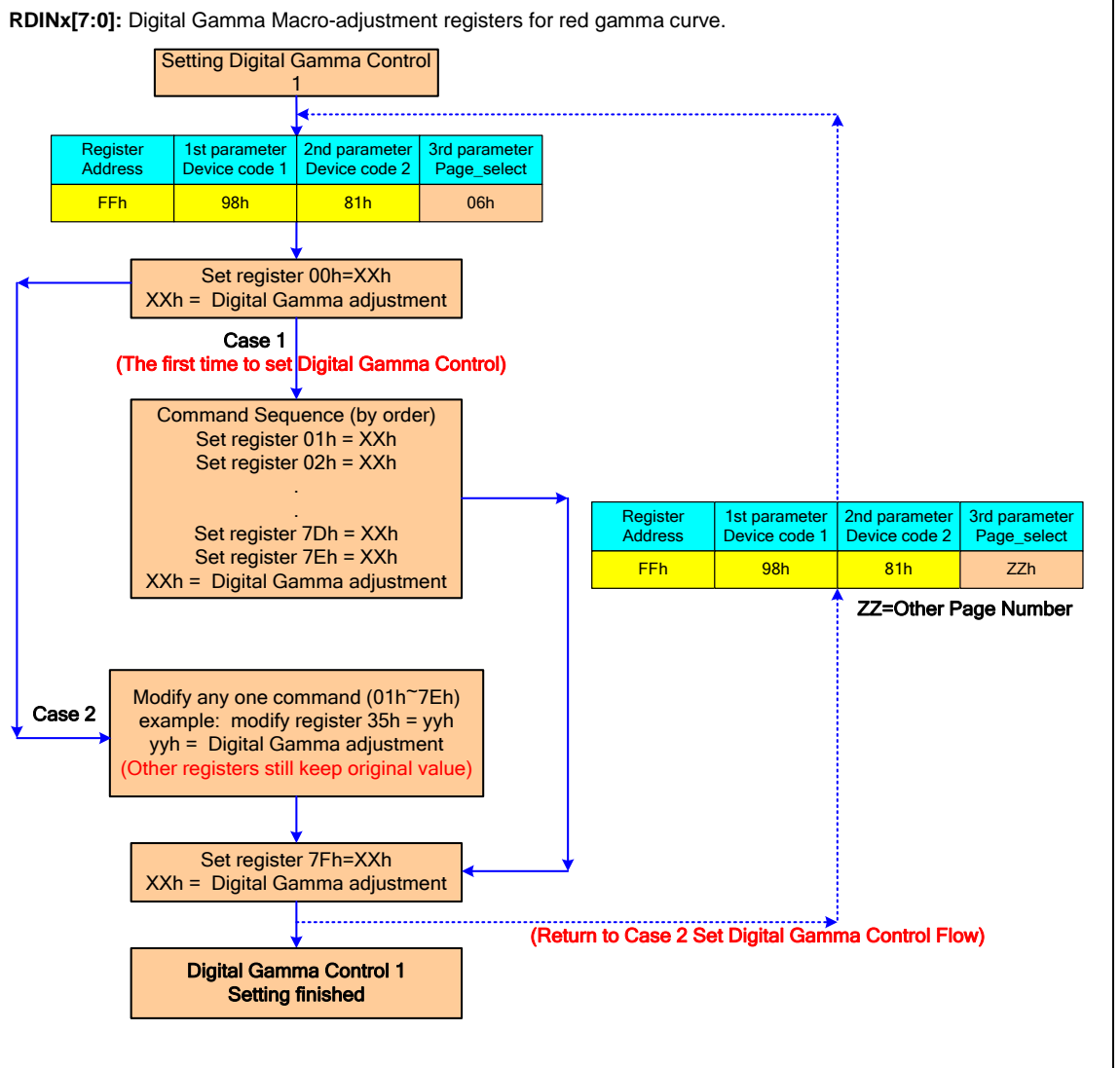

Restriction	None
-------------	------

<p>Register Availability</p>	<table border="1"> <thead> <tr> <th>Status</th> <th>Availability</th> </tr> </thead> <tbody> <tr> <td>Normal Mode On, Idle Mode Off, Sleep Out</td> <td>Yes</td> </tr> <tr> <td>Normal Mode On, Idle Mode On, Sleep Out</td> <td>Yes</td> </tr> <tr> <td>Sleep In</td> <td>Yes</td> </tr> </tbody> </table>	Status	Availability	Normal Mode On, Idle Mode Off, Sleep Out	Yes	Normal Mode On, Idle Mode On, Sleep Out	Yes	Sleep In	Yes
Status	Availability								
Normal Mode On, Idle Mode Off, Sleep Out	Yes								
Normal Mode On, Idle Mode On, Sleep Out	Yes								
Sleep In	Yes								
<p>Default</p>	<table border="1"> <thead> <tr> <th>Status</th> <th>Default Value</th> </tr> </thead> <tbody> <tr> <td>Power On Sequence</td> <td>00h_00h...00h_00h</td> </tr> <tr> <td>S/W Reset</td> <td>00h_00h...00h_00h</td> </tr> <tr> <td>H/W Reset</td> <td>00h_00h...00h_00h</td> </tr> </tbody> </table>	Status	Default Value	Power On Sequence	00h_00h...00h_00h	S/W Reset	00h_00h...00h_00h	H/W Reset	00h_00h...00h_00h
Status	Default Value								
Power On Sequence	00h_00h...00h_00h								
S/W Reset	00h_00h...00h_00h								
H/W Reset	00h_00h...00h_00h								

5.9.2. EXTC Command Set Enable Register (FFh)

Command Page			Page 6																																		
Address	Parameter	W/R	D7	D6	D5	D4	D3	D2	D1	D0	Default																										
FFh	1st	W	1	0	0	1	1	0	0	0	98h																										
	2nd	W	1	0	0	0	0	0	0	1	81h																										
	3rd	W	PAGE[7:0]								06h																										
Description	<p>PAGE[7:0]: Set the command page.</p> <table border="1"> <thead> <tr> <th>PAGE[7:0]</th> <th>Command Page</th> </tr> </thead> <tbody> <tr><td>00h</td><td>Page 0</td></tr> <tr><td>01h</td><td>Page 1</td></tr> <tr><td>02h</td><td>Page 2</td></tr> <tr><td>03h</td><td>Page 3</td></tr> <tr><td>04h</td><td>Page 4</td></tr> <tr><td>05h</td><td>Page 5</td></tr> <tr><td>06h</td><td>Page 6</td></tr> <tr><td>07h</td><td>Page 7</td></tr> <tr><td>08h</td><td>Page 8</td></tr> <tr><td>09h</td><td>Page 9</td></tr> <tr><td>0Ah</td><td>Page 10</td></tr> <tr><td>Others</td><td>Reserved</td></tr> </tbody> </table> <p>Set the register, 1st Parameter = 98h, 2nd Parameter = 81h, 3rd Parameter = Page value to enable "Page command set" available</p> <p>See section "5.1 Command Flow".</p>											PAGE[7:0]	Command Page	00h	Page 0	01h	Page 1	02h	Page 2	03h	Page 3	04h	Page 4	05h	Page 5	06h	Page 6	07h	Page 7	08h	Page 8	09h	Page 9	0Ah	Page 10	Others	Reserved
	PAGE[7:0]	Command Page																																			
	00h	Page 0																																			
	01h	Page 1																																			
	02h	Page 2																																			
	03h	Page 3																																			
	04h	Page 4																																			
	05h	Page 5																																			
	06h	Page 6																																			
	07h	Page 7																																			
	08h	Page 8																																			
	09h	Page 9																																			
	0Ah	Page 10																																			
Others	Reserved																																				
Restriction	None																																				
Register Availability	<table border="1"> <thead> <tr> <th>Status</th> <th>Availability</th> </tr> </thead> <tbody> <tr> <td>Normal Mode On, Idle Mode Off, Sleep Out</td> <td>Yes</td> </tr> <tr> <td>Normal Mode On, Idle Mode On, Sleep Out</td> <td>Yes</td> </tr> <tr> <td>Sleep In</td> <td>Yes</td> </tr> </tbody> </table>											Status	Availability	Normal Mode On, Idle Mode Off, Sleep Out	Yes	Normal Mode On, Idle Mode On, Sleep Out	Yes	Sleep In	Yes																		
Status	Availability																																				
Normal Mode On, Idle Mode Off, Sleep Out	Yes																																				
Normal Mode On, Idle Mode On, Sleep Out	Yes																																				
Sleep In	Yes																																				
Default	<table border="1"> <thead> <tr> <th>Status</th> <th>Default Value</th> </tr> </thead> <tbody> <tr> <td>Power On Sequence</td> <td>06h</td> </tr> <tr> <td>S/W Reset</td> <td>06h</td> </tr> <tr> <td>H/W Reset</td> <td>06h</td> </tr> </tbody> </table>											Status	Default Value	Power On Sequence	06h	S/W Reset	06h	H/W Reset	06h																		
Status	Default Value																																				
Power On Sequence	06h																																				
S/W Reset	06h																																				
H/W Reset	06h																																				

5.10. Page 7 Command Description

5.10.1. Fine Digital Gamma Control 3 (00h~7Fh)

Command Page			Page 7								
Address	Parameter	W/R	D7	D6	D5	D4	D3	D2	D1	D0	Default
00h	1st	W	GDIN0[7:0]							00h	
01h	1st	W	GDIN1[7:0]							00h	
02h	1st	W	GDIN2[7:0]							00h	
03h	1st	W	GDIN3[7:0]							00h	
04h	1st	W	GDIN4[7:0]							00h	
05h	1st	W	GDIN5[7:0]							00h	
:	1st	W	:							00h	
7Ah	1st	W	GDIN122[7:0]							00h	
7Bh	1st	W	GDIN123[7:0]							00h	
7Ch	1st	W	GDIN124[7:0]							00h	
7Dh	1st	W	GDIN125[7:0]							00h	
7Eh	1st	W	GDIN126[7:0]							00h	
7Fh	1st	W	GDIN127[7:0]							00h	

GDINx[7:0]: Digital Gamma Macro-adjustment registers for green gamma curve.

Setting Digital Gamma Control 1

Register Address	1st parameter Device code 1	2nd parameter Device code 2	3rd parameter Page_select
FFh	98h	81h	07h

Set register 00h=XXh
XXh = Digital Gamma adjustment

Case 1
(The first time to set Digital Gamma Control)

Command Sequence (by order)
Set register 01h = XXh
Set register 02h = XXh
.
Set register 7Dh = XXh
Set register 7Eh = XXh
XXh = Digital Gamma adjustment

Register Address	1st parameter Device code 1	2nd parameter Device code 2	3rd parameter Page_select
FFh	98h	81h	ZZh

ZZ=Other Page Number

Case 2
Modify any one command (01h~7Eh)
example: modify register 35h = yyh
yyh = Digital Gamma adjustment
(Other registers still keep original value)

Set register 7Fh=XXh
XXh = Digital Gamma adjustment

Digital Gamma Control 1 Setting finished

(Return to Case 2 Set Digital Gamma Control Flow)

Description

Restriction: None

<p>Register Availability</p>	<table border="1"> <thead> <tr> <th>Status</th> <th>Availability</th> </tr> </thead> <tbody> <tr> <td>Normal Mode On, Idle Mode Off, Sleep Out</td> <td>Yes</td> </tr> <tr> <td>Normal Mode On, Idle Mode On, Sleep Out</td> <td>Yes</td> </tr> <tr> <td>Sleep In</td> <td>Yes</td> </tr> </tbody> </table>	Status	Availability	Normal Mode On, Idle Mode Off, Sleep Out	Yes	Normal Mode On, Idle Mode On, Sleep Out	Yes	Sleep In	Yes
Status	Availability								
Normal Mode On, Idle Mode Off, Sleep Out	Yes								
Normal Mode On, Idle Mode On, Sleep Out	Yes								
Sleep In	Yes								
<p>Default</p>	<table border="1"> <thead> <tr> <th>Status</th> <th>Default Value</th> </tr> </thead> <tbody> <tr> <td>Power On Sequence</td> <td>00h_00h...00h_00h</td> </tr> <tr> <td>S/W Reset</td> <td>00h_00h...00h_00h</td> </tr> <tr> <td>H/W Reset</td> <td>00h_00h...00h_00h</td> </tr> </tbody> </table>	Status	Default Value	Power On Sequence	00h_00h...00h_00h	S/W Reset	00h_00h...00h_00h	H/W Reset	00h_00h...00h_00h
Status	Default Value								
Power On Sequence	00h_00h...00h_00h								
S/W Reset	00h_00h...00h_00h								
H/W Reset	00h_00h...00h_00h								

5.10.2. EXTC Command Set Enable Register (FFh)

Command Page			Page 7																																		
Address	Parameter	W/R	D7	D6	D5	D4	D3	D2	D1	D0	Default																										
FFh	1st	W	1	0	0	1	1	0	0	0	98h																										
	2nd	W	1	0	0	0	0	0	0	1	81h																										
	3rd	W	PAGE[7:0]								07h																										
Description	<p>PAGE[7:0]: Set the command page.</p> <table border="1"> <thead> <tr> <th>PAGE[7:0]</th> <th>Command Page</th> </tr> </thead> <tbody> <tr><td>00h</td><td>Page 0</td></tr> <tr><td>01h</td><td>Page 1</td></tr> <tr><td>02h</td><td>Page 2</td></tr> <tr><td>03h</td><td>Page 3</td></tr> <tr><td>04h</td><td>Page 4</td></tr> <tr><td>05h</td><td>Page 5</td></tr> <tr><td>06h</td><td>Page 6</td></tr> <tr><td>07h</td><td>Page 7</td></tr> <tr><td>08h</td><td>Page 8</td></tr> <tr><td>09h</td><td>Page 9</td></tr> <tr><td>0Ah</td><td>Page 10</td></tr> <tr><td>Others</td><td>Reserved</td></tr> </tbody> </table> <p>Set the register, 1st Parameter = 98h, 2nd Parameter = 81h, 3rd Parameter = Page value to enable "Page command set" available</p> <p>See section "5.1 Command Flow".</p>											PAGE[7:0]	Command Page	00h	Page 0	01h	Page 1	02h	Page 2	03h	Page 3	04h	Page 4	05h	Page 5	06h	Page 6	07h	Page 7	08h	Page 8	09h	Page 9	0Ah	Page 10	Others	Reserved
	PAGE[7:0]	Command Page																																			
	00h	Page 0																																			
	01h	Page 1																																			
	02h	Page 2																																			
	03h	Page 3																																			
	04h	Page 4																																			
	05h	Page 5																																			
	06h	Page 6																																			
	07h	Page 7																																			
	08h	Page 8																																			
	09h	Page 9																																			
	0Ah	Page 10																																			
Others	Reserved																																				
Restriction	None																																				
Register Availability	<table border="1"> <thead> <tr> <th>Status</th> <th>Availability</th> </tr> </thead> <tbody> <tr> <td>Normal Mode On, Idle Mode Off, Sleep Out</td> <td>Yes</td> </tr> <tr> <td>Normal Mode On, Idle Mode On, Sleep Out</td> <td>Yes</td> </tr> <tr> <td>Sleep In</td> <td>Yes</td> </tr> </tbody> </table>											Status	Availability	Normal Mode On, Idle Mode Off, Sleep Out	Yes	Normal Mode On, Idle Mode On, Sleep Out	Yes	Sleep In	Yes																		
Status	Availability																																				
Normal Mode On, Idle Mode Off, Sleep Out	Yes																																				
Normal Mode On, Idle Mode On, Sleep Out	Yes																																				
Sleep In	Yes																																				
Default	<table border="1"> <thead> <tr> <th>Status</th> <th>Default Value</th> </tr> </thead> <tbody> <tr> <td>Power On Sequence</td> <td>07h</td> </tr> <tr> <td>S/W Reset</td> <td>07h</td> </tr> <tr> <td>H/W Reset</td> <td>07h</td> </tr> </tbody> </table>											Status	Default Value	Power On Sequence	07h	S/W Reset	07h	H/W Reset	07h																		
Status	Default Value																																				
Power On Sequence	07h																																				
S/W Reset	07h																																				
H/W Reset	07h																																				

5.11. Page 8 Command Description

5.11.1. Fine Digital Gamma Control 4 (00h~7Fh)

Command Page			Page 8								
Address	Parameter	W/R	D7	D6	D5	D4	D3	D2	D1	D0	Default
00h	1st	W									00h
01h	1st	W									00h
02h	1st	W									00h
03h	1st	W									00h
04h	1st	W									00h
05h	1st	W									00h
:	1st	W									00h
7Ah	1st	W									00h
7Bh	1st	W									00h
7Ch	1st	W									00h
7Dh	1st	W									00h
7Eh	1st	W									00h
7Fh	1st	W									00h

Description	<p>GDINx[7:0]: Digital Gamma Macro-adjustment registers for green gamma curve.</p> <p>Setting Digital Gamma Control 1</p> <table border="1"> <thead> <tr> <th>Register Address</th> <th>1st parameter Device code 1</th> <th>2nd parameter Device code 2</th> <th>3rd parameter Page_select</th> </tr> </thead> <tbody> <tr> <td>FFh</td> <td>98h</td> <td>81h</td> <td>08h</td> </tr> </tbody> </table> <p>Set register 00h=XXh XXh = Digital Gamma adjustment</p> <p>Case 1 (The first time to set Digital Gamma Control)</p> <p>Command Sequence (by order) Set register 01h = XXh Set register 02h = XXh . Set register 7Dh = XXh Set register 7Eh = XXh XXh = Digital Gamma adjustment</p> <table border="1"> <thead> <tr> <th>Register Address</th> <th>1st parameter Device code 1</th> <th>2nd parameter Device code 2</th> <th>3rd parameter Page_select</th> </tr> </thead> <tbody> <tr> <td>FFh</td> <td>98h</td> <td>81h</td> <td>ZZh</td> </tr> </tbody> </table> <p>ZZ=Other Page Number</p> <p>Case 2 Modify any one command (01h~7Eh) example: modify register 35h = yyh yyh = Digital Gamma adjustment (Other registers still keep original value)</p> <p>Set register 7Fh=XXh XXh = Digital Gamma adjustment</p> <p>Digital Gamma Control 1 Setting finished</p> <p>(Return to Case 2 Set Digital Gamma Control Flow)</p>	Register Address	1st parameter Device code 1	2nd parameter Device code 2	3rd parameter Page_select	FFh	98h	81h	08h	Register Address	1st parameter Device code 1	2nd parameter Device code 2	3rd parameter Page_select	FFh	98h	81h	ZZh
	Register Address	1st parameter Device code 1	2nd parameter Device code 2	3rd parameter Page_select													
FFh	98h	81h	08h														
Register Address	1st parameter Device code 1	2nd parameter Device code 2	3rd parameter Page_select														
FFh	98h	81h	ZZh														
Restriction	None																

<p>Register Availability</p>	<table border="1"> <thead> <tr> <th data-bbox="604 230 1045 264">Status</th> <th data-bbox="1045 230 1286 264">Availability</th> </tr> </thead> <tbody> <tr> <td data-bbox="604 264 1045 297">Normal Mode On, Idle Mode Off, Sleep Out</td> <td data-bbox="1045 264 1286 297">Yes</td> </tr> <tr> <td data-bbox="604 297 1045 331">Normal Mode On, Idle Mode On, Sleep Out</td> <td data-bbox="1045 297 1286 331">Yes</td> </tr> <tr> <td data-bbox="604 331 1045 365">Sleep In</td> <td data-bbox="1045 331 1286 365">Yes</td> </tr> </tbody> </table>	Status	Availability	Normal Mode On, Idle Mode Off, Sleep Out	Yes	Normal Mode On, Idle Mode On, Sleep Out	Yes	Sleep In	Yes
Status	Availability								
Normal Mode On, Idle Mode Off, Sleep Out	Yes								
Normal Mode On, Idle Mode On, Sleep Out	Yes								
Sleep In	Yes								
<p>Default</p>	<table border="1"> <thead> <tr> <th data-bbox="681 427 933 461">Status</th> <th data-bbox="933 427 1208 461">Default Value</th> </tr> </thead> <tbody> <tr> <td data-bbox="681 461 933 495">Power On Sequence</td> <td data-bbox="933 461 1208 495">00h_00h...00h_00h</td> </tr> <tr> <td data-bbox="681 495 933 528">S/W Reset</td> <td data-bbox="933 495 1208 528">00h_00h...00h_00h</td> </tr> <tr> <td data-bbox="681 528 933 562">H/W Reset</td> <td data-bbox="933 528 1208 562">00h_00h...00h_00h</td> </tr> </tbody> </table>	Status	Default Value	Power On Sequence	00h_00h...00h_00h	S/W Reset	00h_00h...00h_00h	H/W Reset	00h_00h...00h_00h
Status	Default Value								
Power On Sequence	00h_00h...00h_00h								
S/W Reset	00h_00h...00h_00h								
H/W Reset	00h_00h...00h_00h								

5.11.2. EXTC Command Set Enable Register (FFh)

Command Page			Page 8																																		
Address	Parameter	W/R	D7	D6	D5	D4	D3	D2	D1	D0	Default																										
FFh	1st	W	1	0	0	1	1	0	0	0	98h																										
	2nd	W	1	0	0	0	0	0	0	1	81h																										
	3rd	W	PAGE[7:0]								08h																										
Description	<p>PAGE[7:0]: Set the command page.</p> <table border="1"> <thead> <tr> <th>PAGE[7:0]</th> <th>Command Page</th> </tr> </thead> <tbody> <tr><td>00h</td><td>Page 0</td></tr> <tr><td>01h</td><td>Page 1</td></tr> <tr><td>02h</td><td>Page 2</td></tr> <tr><td>03h</td><td>Page 3</td></tr> <tr><td>04h</td><td>Page 4</td></tr> <tr><td>05h</td><td>Page 5</td></tr> <tr><td>06h</td><td>Page 6</td></tr> <tr><td>07h</td><td>Page 7</td></tr> <tr><td>08h</td><td>Page 8</td></tr> <tr><td>09h</td><td>Page 9</td></tr> <tr><td>0Ah</td><td>Page 10</td></tr> <tr><td>Others</td><td>Reserved</td></tr> </tbody> </table> <p>Set the register, 1st Parameter = 98h, 2nd Parameter = 81h, 3rd Parameter = Page value to enable "Page command set" available</p> <p>See section "5.1 Command Flow".</p>											PAGE[7:0]	Command Page	00h	Page 0	01h	Page 1	02h	Page 2	03h	Page 3	04h	Page 4	05h	Page 5	06h	Page 6	07h	Page 7	08h	Page 8	09h	Page 9	0Ah	Page 10	Others	Reserved
	PAGE[7:0]	Command Page																																			
	00h	Page 0																																			
	01h	Page 1																																			
	02h	Page 2																																			
	03h	Page 3																																			
	04h	Page 4																																			
	05h	Page 5																																			
	06h	Page 6																																			
	07h	Page 7																																			
	08h	Page 8																																			
	09h	Page 9																																			
	0Ah	Page 10																																			
Others	Reserved																																				
Restriction	None																																				
Register Availability	<table border="1"> <thead> <tr> <th>Status</th> <th>Availability</th> </tr> </thead> <tbody> <tr> <td>Normal Mode On, Idle Mode Off, Sleep Out</td> <td>Yes</td> </tr> <tr> <td>Normal Mode On, Idle Mode On, Sleep Out</td> <td>Yes</td> </tr> <tr> <td>Sleep In</td> <td>Yes</td> </tr> </tbody> </table>											Status	Availability	Normal Mode On, Idle Mode Off, Sleep Out	Yes	Normal Mode On, Idle Mode On, Sleep Out	Yes	Sleep In	Yes																		
Status	Availability																																				
Normal Mode On, Idle Mode Off, Sleep Out	Yes																																				
Normal Mode On, Idle Mode On, Sleep Out	Yes																																				
Sleep In	Yes																																				
Default	<table border="1"> <thead> <tr> <th>Status</th> <th>Default Value</th> </tr> </thead> <tbody> <tr> <td>Power On Sequence</td> <td>08h</td> </tr> <tr> <td>S/W Reset</td> <td>08h</td> </tr> <tr> <td>H/W Reset</td> <td>08h</td> </tr> </tbody> </table>											Status	Default Value	Power On Sequence	08h	S/W Reset	08h	H/W Reset	08h																		
Status	Default Value																																				
Power On Sequence	08h																																				
S/W Reset	08h																																				
H/W Reset	08h																																				

5.12. Page 9 Command Description

5.12.1. Fine Digital Gamma Control 5 (00h~7Fh)

Command Page			Page 9								
Address	Parameter	W/R	D7	D6	D5	D4	D3	D2	D1	D0	Default
00h	1st	W	BDIN0[7:0]								00h
01h	1st	W	BDIN1[7:0]								00h
02h	1st	W	BDIN2[7:0]								00h
03h	1st	W	BDIN3[7:0]								00h
04h	1st	W	BDIN4[7:0]								00h
05h	1st	W	BDIN5[7:0]								00h
:	1st	W	:								00h
7Ah	1st	W	BDIN122[7:0]								00h
7Bh	1st	W	BDIN123[7:0]								00h
7Ch	1st	W	BDIN124[7:0]								00h
7Dh	1st	W	BDIN125[7:0]								00h
7Eh	1st	W	BDIN126[7:0]								00h
7Fh	1st	W	BDIN127[7:0]								00h

BDINx[7:0]: Digital Gamma Macro-adjustment registers for blue gamma curve.

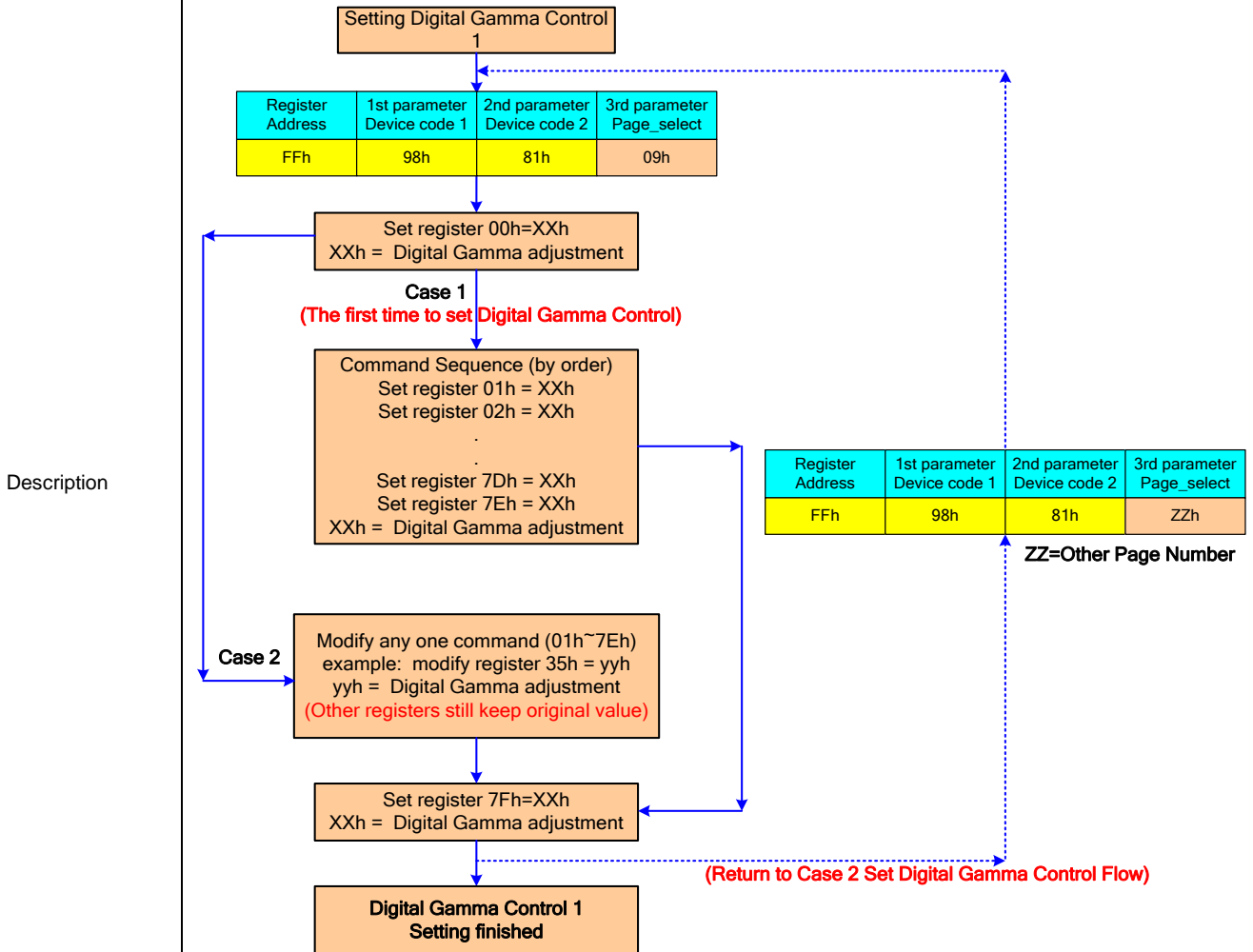

Restriction None

<p>Register Availability</p>	<table border="1"> <thead> <tr> <th data-bbox="604 241 1045 277">Status</th> <th data-bbox="1045 241 1286 277">Availability</th> </tr> </thead> <tbody> <tr> <td data-bbox="604 277 1045 309">Normal Mode On, Idle Mode Off, Sleep Out</td> <td data-bbox="1045 277 1286 309">Yes</td> </tr> <tr> <td data-bbox="604 309 1045 340">Normal Mode On, Idle Mode On, Sleep Out</td> <td data-bbox="1045 309 1286 340">Yes</td> </tr> <tr> <td data-bbox="604 340 1045 371">Sleep In</td> <td data-bbox="1045 340 1286 371">Yes</td> </tr> </tbody> </table>	Status	Availability	Normal Mode On, Idle Mode Off, Sleep Out	Yes	Normal Mode On, Idle Mode On, Sleep Out	Yes	Sleep In	Yes
Status	Availability								
Normal Mode On, Idle Mode Off, Sleep Out	Yes								
Normal Mode On, Idle Mode On, Sleep Out	Yes								
Sleep In	Yes								
<p>Default</p>	<table border="1"> <thead> <tr> <th data-bbox="681 445 933 481">Status</th> <th data-bbox="933 445 1208 481">Default Value</th> </tr> </thead> <tbody> <tr> <td data-bbox="681 481 933 512">Power On Sequence</td> <td data-bbox="933 481 1208 512">00h_00h...00h_00h</td> </tr> <tr> <td data-bbox="681 512 933 544">S/W Reset</td> <td data-bbox="933 512 1208 544">00h_00h...00h_00h</td> </tr> <tr> <td data-bbox="681 544 933 575">H/W Reset</td> <td data-bbox="933 544 1208 575">00h_00h...00h_00h</td> </tr> </tbody> </table>	Status	Default Value	Power On Sequence	00h_00h...00h_00h	S/W Reset	00h_00h...00h_00h	H/W Reset	00h_00h...00h_00h
Status	Default Value								
Power On Sequence	00h_00h...00h_00h								
S/W Reset	00h_00h...00h_00h								
H/W Reset	00h_00h...00h_00h								

5.12.2. EXTC Command Set Enable Register (FFh)

Command Page			Page 9																																		
Address	Parameter	W/R	D7	D6	D5	D4	D3	D2	D1	D0	Default																										
FFh	1st	W	1	0	0	1	1	0	0	0	98h																										
	2nd	W	1	0	0	0	0	0	0	1	81h																										
	3rd	W	PAGE[7:0]								09h																										
Description	<p>PAGE[7:0]: Set the command page.</p> <table border="1"> <thead> <tr> <th>PAGE[7:0]</th> <th>Command Page</th> </tr> </thead> <tbody> <tr><td>00h</td><td>Page 0</td></tr> <tr><td>01h</td><td>Page 1</td></tr> <tr><td>02h</td><td>Page 2</td></tr> <tr><td>03h</td><td>Page 3</td></tr> <tr><td>04h</td><td>Page 4</td></tr> <tr><td>05h</td><td>Page 5</td></tr> <tr><td>06h</td><td>Page 6</td></tr> <tr><td>07h</td><td>Page 7</td></tr> <tr><td>08h</td><td>Page 8</td></tr> <tr><td>09h</td><td>Page 9</td></tr> <tr><td>0Ah</td><td>Page 10</td></tr> <tr><td>Others</td><td>Reserved</td></tr> </tbody> </table> <p>Set the register, 1st Parameter = 98h, 2nd Parameter = 81h, 3rd Parameter = Page value to enable "Page command set" available</p> <p>See section "5.1 Command Flow".</p>											PAGE[7:0]	Command Page	00h	Page 0	01h	Page 1	02h	Page 2	03h	Page 3	04h	Page 4	05h	Page 5	06h	Page 6	07h	Page 7	08h	Page 8	09h	Page 9	0Ah	Page 10	Others	Reserved
	PAGE[7:0]	Command Page																																			
	00h	Page 0																																			
	01h	Page 1																																			
	02h	Page 2																																			
	03h	Page 3																																			
	04h	Page 4																																			
	05h	Page 5																																			
	06h	Page 6																																			
	07h	Page 7																																			
	08h	Page 8																																			
	09h	Page 9																																			
	0Ah	Page 10																																			
Others	Reserved																																				
Restriction	None																																				
Register Availability	<table border="1"> <thead> <tr> <th>Status</th> <th>Availability</th> </tr> </thead> <tbody> <tr> <td>Normal Mode On, Idle Mode Off, Sleep Out</td> <td>Yes</td> </tr> <tr> <td>Normal Mode On, Idle Mode On, Sleep Out</td> <td>Yes</td> </tr> <tr> <td>Sleep In</td> <td>Yes</td> </tr> </tbody> </table>											Status	Availability	Normal Mode On, Idle Mode Off, Sleep Out	Yes	Normal Mode On, Idle Mode On, Sleep Out	Yes	Sleep In	Yes																		
Status	Availability																																				
Normal Mode On, Idle Mode Off, Sleep Out	Yes																																				
Normal Mode On, Idle Mode On, Sleep Out	Yes																																				
Sleep In	Yes																																				
Default	<table border="1"> <thead> <tr> <th>Status</th> <th>Default Value</th> </tr> </thead> <tbody> <tr> <td>Power On Sequence</td> <td>09h</td> </tr> <tr> <td>S/W Reset</td> <td>09h</td> </tr> <tr> <td>H/W Reset</td> <td>09h</td> </tr> </tbody> </table>											Status	Default Value	Power On Sequence	09h	S/W Reset	09h	H/W Reset	09h																		
Status	Default Value																																				
Power On Sequence	09h																																				
S/W Reset	09h																																				
H/W Reset	09h																																				

5.13. Page 10 Command Description

5.13.1. Fine Digital Gamma Control 6 (00h~7Fh)

Command Page			Page 10								
Address	Parameter	W/R	D7	D6	D5	D4	D3	D2	D1	D0	Default
00h	1st	W	BDIN128[7:0]								00h
01h	1st	W	BDIN129[7:0]								00h
02h	1st	W	BDIN130[7:0]								00h
03h	1st	W	BDIN131[7:0]								00h
04h	1st	W	BDIN132[7:0]								00h
05h	1st	W	BDIN133[7:0]								00h
:	1st	W	:								00h
7Ah	1st	W	BDIN250[7:0]								00h
7Bh	1st	W	BDIN251[7:0]								00h
7Ch	1st	W	BDIN252[7:0]								00h
7Dh	1st	W	BDIN253[7:0]								00h
7Eh	1st	W	BDIN254[7:0]								00h
7Fh	1st	W	BDIN255[7:0]								00h

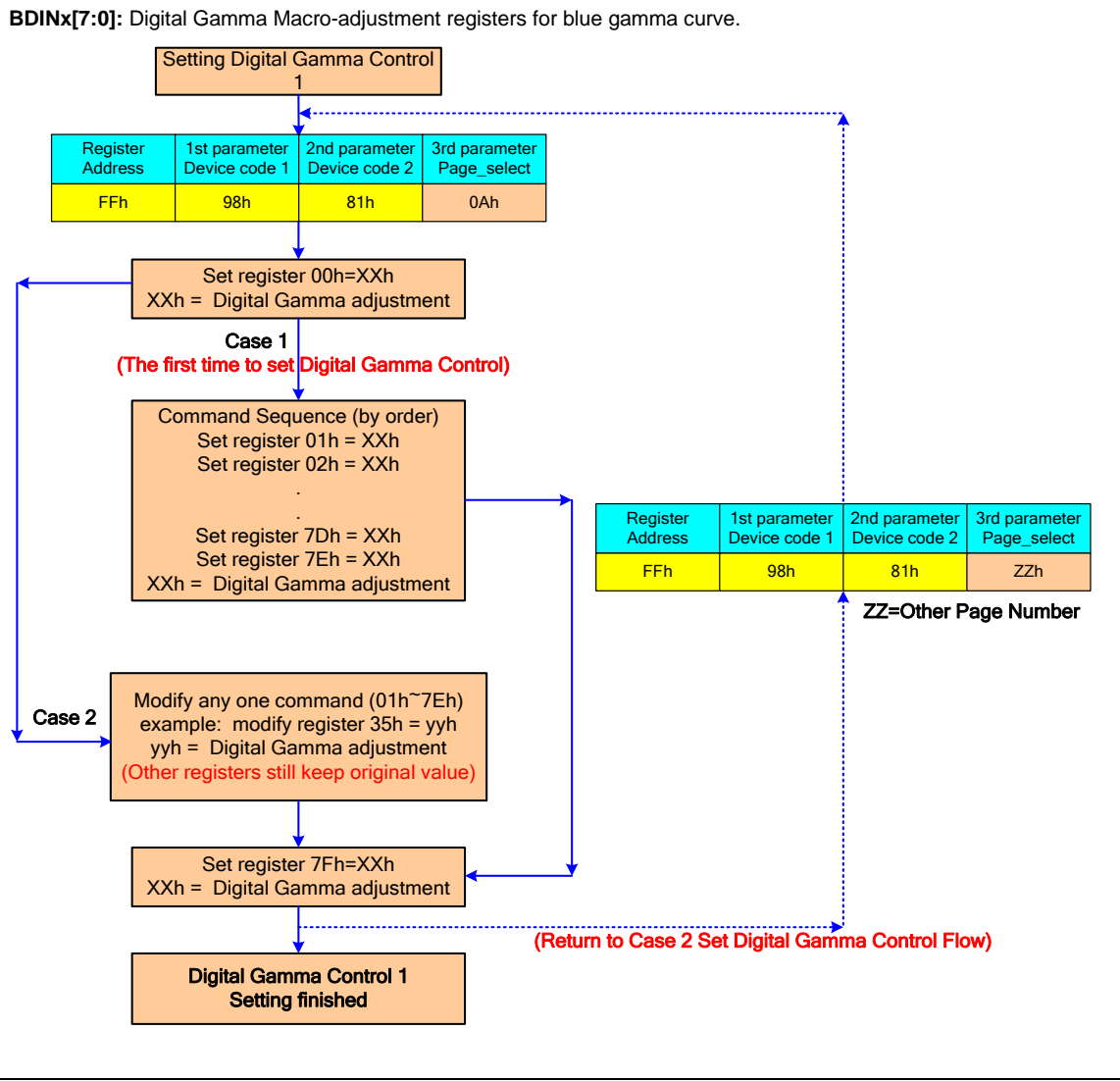

Restriction	None
-------------	------

<p>Register Availability</p>	<table border="1"> <thead> <tr> <th data-bbox="606 232 1046 264">Status</th> <th data-bbox="1046 232 1286 264">Availability</th> </tr> </thead> <tbody> <tr> <td data-bbox="606 264 1046 297">Normal Mode On, Idle Mode Off, Sleep Out</td> <td data-bbox="1046 264 1286 297">Yes</td> </tr> <tr> <td data-bbox="606 297 1046 331">Normal Mode On, Idle Mode On, Sleep Out</td> <td data-bbox="1046 297 1286 331">Yes</td> </tr> <tr> <td data-bbox="606 331 1046 365">Sleep In</td> <td data-bbox="1046 331 1286 365">Yes</td> </tr> </tbody> </table>	Status	Availability	Normal Mode On, Idle Mode Off, Sleep Out	Yes	Normal Mode On, Idle Mode On, Sleep Out	Yes	Sleep In	Yes
Status	Availability								
Normal Mode On, Idle Mode Off, Sleep Out	Yes								
Normal Mode On, Idle Mode On, Sleep Out	Yes								
Sleep In	Yes								
<p>Default</p>	<table border="1"> <thead> <tr> <th data-bbox="683 427 935 459">Status</th> <th data-bbox="935 427 1209 459">Default Value</th> </tr> </thead> <tbody> <tr> <td data-bbox="683 459 935 492">Power On Sequence</td> <td data-bbox="935 459 1209 492">00h_00h...00h_00h</td> </tr> <tr> <td data-bbox="683 492 935 526">S/W Reset</td> <td data-bbox="935 492 1209 526">00h_00h...00h_00h</td> </tr> <tr> <td data-bbox="683 526 935 560">H/W Reset</td> <td data-bbox="935 526 1209 560">00h_00h...00h_00h</td> </tr> </tbody> </table>	Status	Default Value	Power On Sequence	00h_00h...00h_00h	S/W Reset	00h_00h...00h_00h	H/W Reset	00h_00h...00h_00h
Status	Default Value								
Power On Sequence	00h_00h...00h_00h								
S/W Reset	00h_00h...00h_00h								
H/W Reset	00h_00h...00h_00h								

5.13.2. EXTC Command Set Enable Register (FFh)

Command Page			Page 10																																		
Address	Parameter	W/R	D7	D6	D5	D4	D3	D2	D1	D0	Default																										
FFh	1st	W	1	0	0	1	1	0	0	0	98h																										
	2nd	W	1	0	0	0	0	0	0	1	81h																										
	3rd	W	PAGE[7:0]								0Ah																										
Description	<p>PAGE[7:0]: Set the command page.</p> <table border="1"> <thead> <tr> <th>PAGE[7:0]</th> <th>Command Page</th> </tr> </thead> <tbody> <tr><td>00h</td><td>Page 0</td></tr> <tr><td>01h</td><td>Page 1</td></tr> <tr><td>02h</td><td>Page 2</td></tr> <tr><td>03h</td><td>Page 3</td></tr> <tr><td>04h</td><td>Page 4</td></tr> <tr><td>05h</td><td>Page 5</td></tr> <tr><td>06h</td><td>Page 6</td></tr> <tr><td>07h</td><td>Page 7</td></tr> <tr><td>08h</td><td>Page 8</td></tr> <tr><td>09h</td><td>Page 9</td></tr> <tr><td>0Ah</td><td>Page 10</td></tr> <tr><td>Others</td><td>Reserved</td></tr> </tbody> </table> <p>Set the register, 1st Parameter = 98h, 2nd Parameter = 81h, 3rd Parameter = Page value to enable "Page command set" available</p> <p>See section "5.1 Command Flow".</p>											PAGE[7:0]	Command Page	00h	Page 0	01h	Page 1	02h	Page 2	03h	Page 3	04h	Page 4	05h	Page 5	06h	Page 6	07h	Page 7	08h	Page 8	09h	Page 9	0Ah	Page 10	Others	Reserved
	PAGE[7:0]	Command Page																																			
	00h	Page 0																																			
	01h	Page 1																																			
	02h	Page 2																																			
	03h	Page 3																																			
	04h	Page 4																																			
	05h	Page 5																																			
	06h	Page 6																																			
	07h	Page 7																																			
	08h	Page 8																																			
	09h	Page 9																																			
	0Ah	Page 10																																			
Others	Reserved																																				
Restriction	None																																				
Register Availability	<table border="1"> <thead> <tr> <th>Status</th> <th>Availability</th> </tr> </thead> <tbody> <tr> <td>Normal Mode On, Idle Mode Off, Sleep Out</td> <td>Yes</td> </tr> <tr> <td>Normal Mode On, Idle Mode On, Sleep Out</td> <td>Yes</td> </tr> <tr> <td>Sleep In</td> <td>Yes</td> </tr> </tbody> </table>											Status	Availability	Normal Mode On, Idle Mode Off, Sleep Out	Yes	Normal Mode On, Idle Mode On, Sleep Out	Yes	Sleep In	Yes																		
Status	Availability																																				
Normal Mode On, Idle Mode Off, Sleep Out	Yes																																				
Normal Mode On, Idle Mode On, Sleep Out	Yes																																				
Sleep In	Yes																																				
Default	<table border="1"> <thead> <tr> <th>Status</th> <th>Default Value</th> </tr> </thead> <tbody> <tr> <td>Power On Sequence</td> <td>0Ah</td> </tr> <tr> <td>S/W Reset</td> <td>0Ah</td> </tr> <tr> <td>H/W Reset</td> <td>0Ah</td> </tr> </tbody> </table>											Status	Default Value	Power On Sequence	0Ah	S/W Reset	0Ah	H/W Reset	0Ah																		
Status	Default Value																																				
Power On Sequence	0Ah																																				
S/W Reset	0Ah																																				
H/W Reset	0Ah																																				

6. Source Driver

The source driver uses 2402 channels (S1~S2400 and SDUM[2:1] channels) for the Zig-zag function used for driving the source line of the TFT LCD panel. The source driver converts the digital data into the analog voltage and generates corresponding gray scale voltage output, enabling up to 16.7M colors to be displayed simultaneously. The output circuit of this source driver incorporates an operational amplifier, so that a positive and a negative voltage can be alternately outputted from each channel.

6.1. Zig-zag Inversion

Zig-zag Inversion is used to reduce the power consumption. The Zig-zag inversion decreases the switching frequency of the source related to the magnitude of power consumption. This method will have an addendum data line, SDUM.

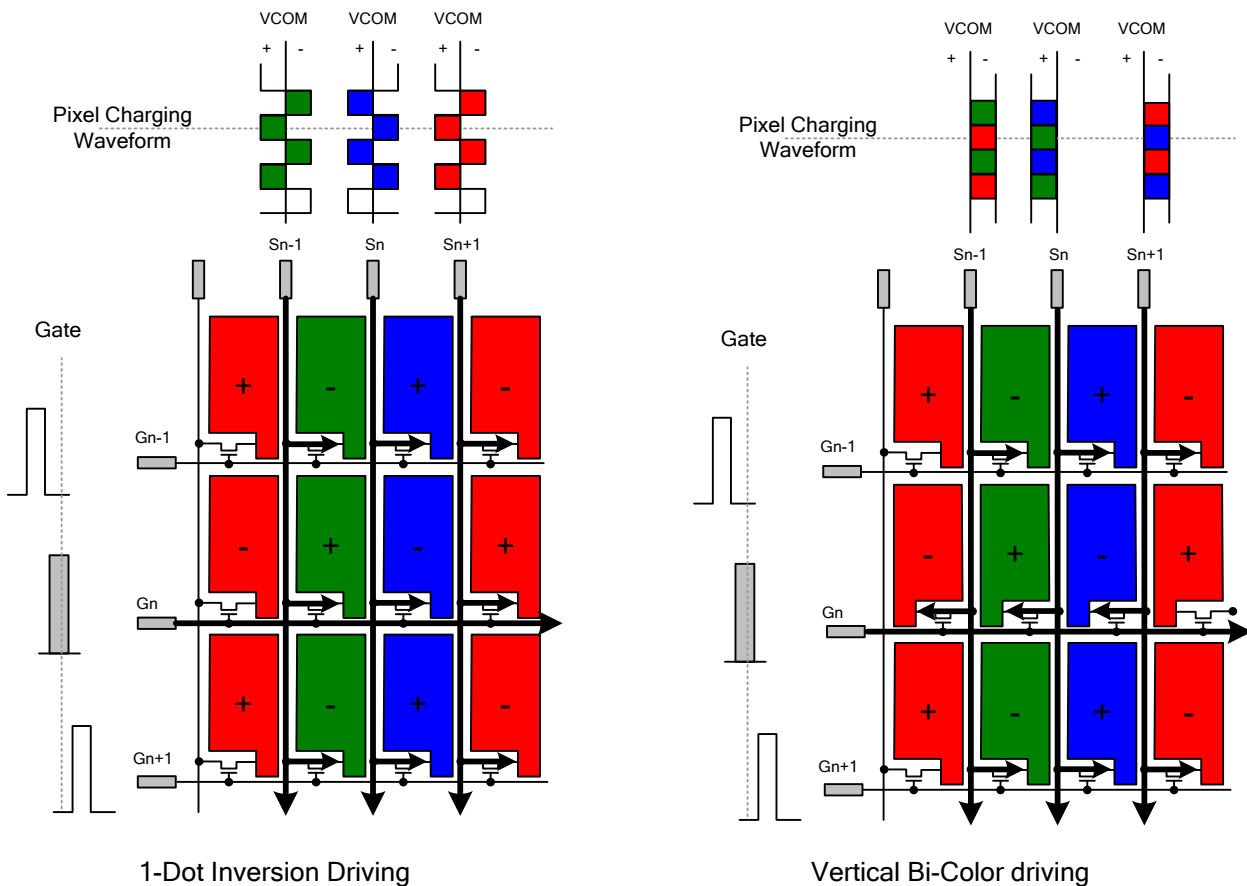

6.2. Zig-zag Inversion Concept

The Zig-zag method uses the same polarity of data line of the column inversion to show the 1-dot inversion.

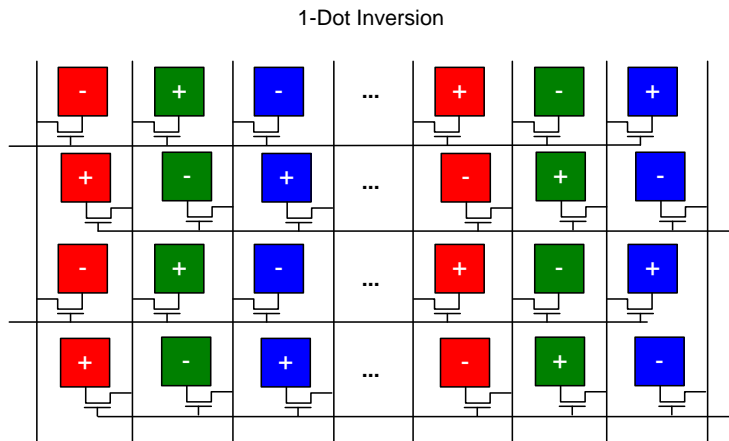
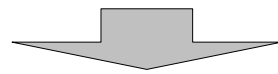
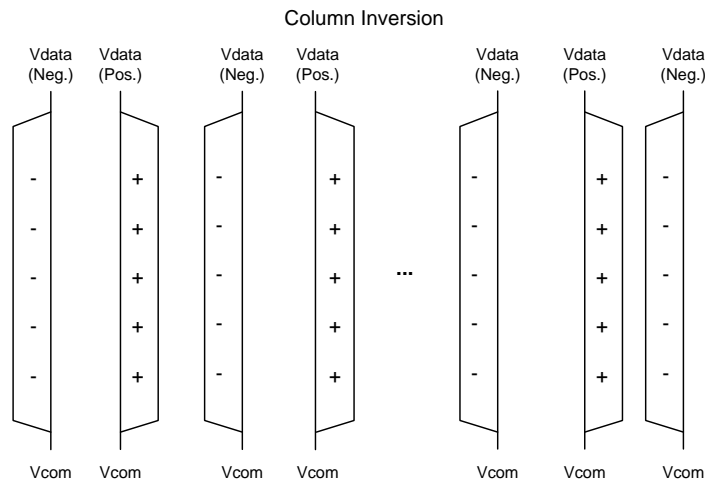
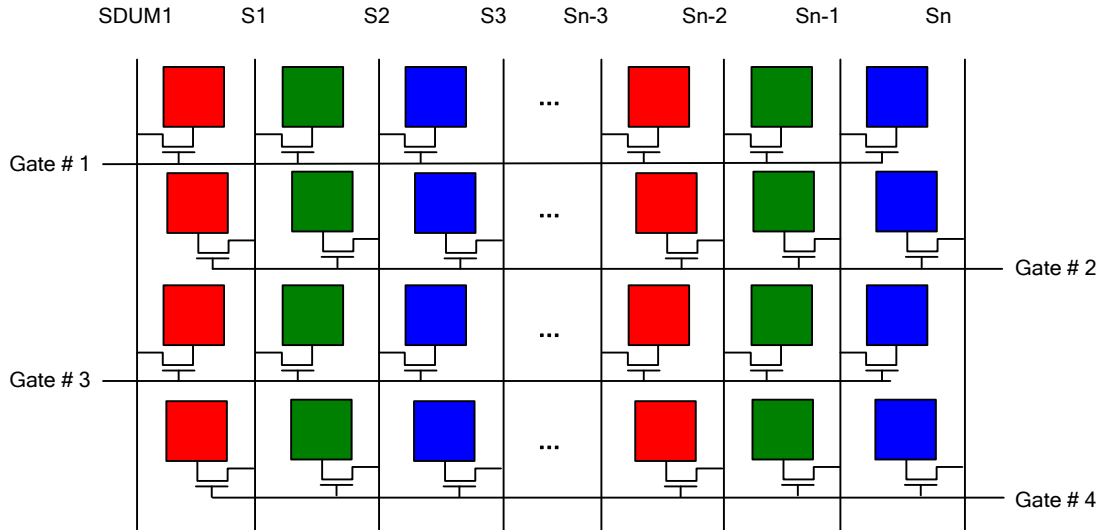

6.3. Zig-zag Inversion Source Output Method

The driving panel display method adds one sub-pixel at the Gate_Even to shift the data output.

(At the Gate_Even line, an additional data line is utilized.)

Red Pattern												
	SDUM1	S1	S2	S3	S4	S5	Sn-5	Sn-4	Sn-3	Sn-2	Sn-1	Sn
Gate_Odd	R1	G1	B1	R2	G2	B2	Gx-1	Bx-1	Rx	Gx	Bx	
Gate_Even		R1	G1	B1	R2	G2	Rx-1	Gx-1	Bx-1	Rx	Gx	Bx
Gate_Odd	R1	G1	B1	R2	G2	B2	Gx-1	Bx-1	Rx	Gx	Bx	
Gate_Even		R1	G1	B1	R2	G2	Rx-1	Gx-1	Bx-1	Rx	Gx	Bx
Gate_Odd	R1	G1	B1	R2	G2	B2	Gx-1	Bx-1	Rx	Gx	Bx	
Gate_Even		R1	G1	B1	R2	G2	Rx-1	Gx-1	Bx-1	Rx	Gx	Bx

Green Pattern												
	SDUM1	S1	S2	S3	S4	S5	Sn-5	Sn-4	Sn-3	Sn-2	Sn-1	Sn
Gate_Odd	R1	G1	B1	R2	G2	B2	Gx-1	Bx-1	Rx	Gx	Bx	
Gate_Even		R1	G1	B1	R2	G2	Rx-1	Gx-1	Bx-1	Rx	Gx	Bx
Gate_Odd	R1	G1	B1	R2	G2	B2	Gx-1	Bx-1	Rx	Gx	Bx	
Gate_Even		R1	G1	B1	R2	G2	Rx-1	Gx-1	Bx-1	Rx	Gx	Bx
Gate_Odd	R1	G1	B1	R2	G2	B2	Gx-1	Bx-1	Rx	Gx	Bx	
Gate_Even		R1	G1	B1	R2	G2	Rx-1	Gx-1	Bx-1	Rx	Gx	Bx

Blue Pattern												
	SDUM1	S1	S2	S3	S4	S5	Sn-5	Sn-4	Sn-3	Sn-2	Sn-1	Sn
Gate_Odd	R1	G1	B1	R2	G2	B2	Gx-1	Bx-1	Rx	Gx	Bx	
Gate_Even		R1	G1	B1	R2	G2	Rx-1	Gx-1	Bx-1	Rx	Gx	Bx
Gate_Odd	R1	G1	B1	R2	G2	B2	Gx-1	Bx-1	Rx	Gx	Bx	
Gate_Even		R1	G1	B1	R2	G2	Rx-1	Gx-1	Bx-1	Rx	Gx	Bx
Gate_Odd	R1	G1	B1	R2	G2	B2	Gx-1	Bx-1	Rx	Gx	Bx	
Gate_Even		R1	G1	B1	R2	G2	Rx-1	Gx-1	Bx-1	Rx	Gx	Bx

6.4. Zig-zag Inversion RED Data Display

The figure below illustrates the Zig-zag inversion panel driving method for Red data input.

When driving a Red pattern, the Red and Blue sub-pixels will light up line by line according to the data signal input.

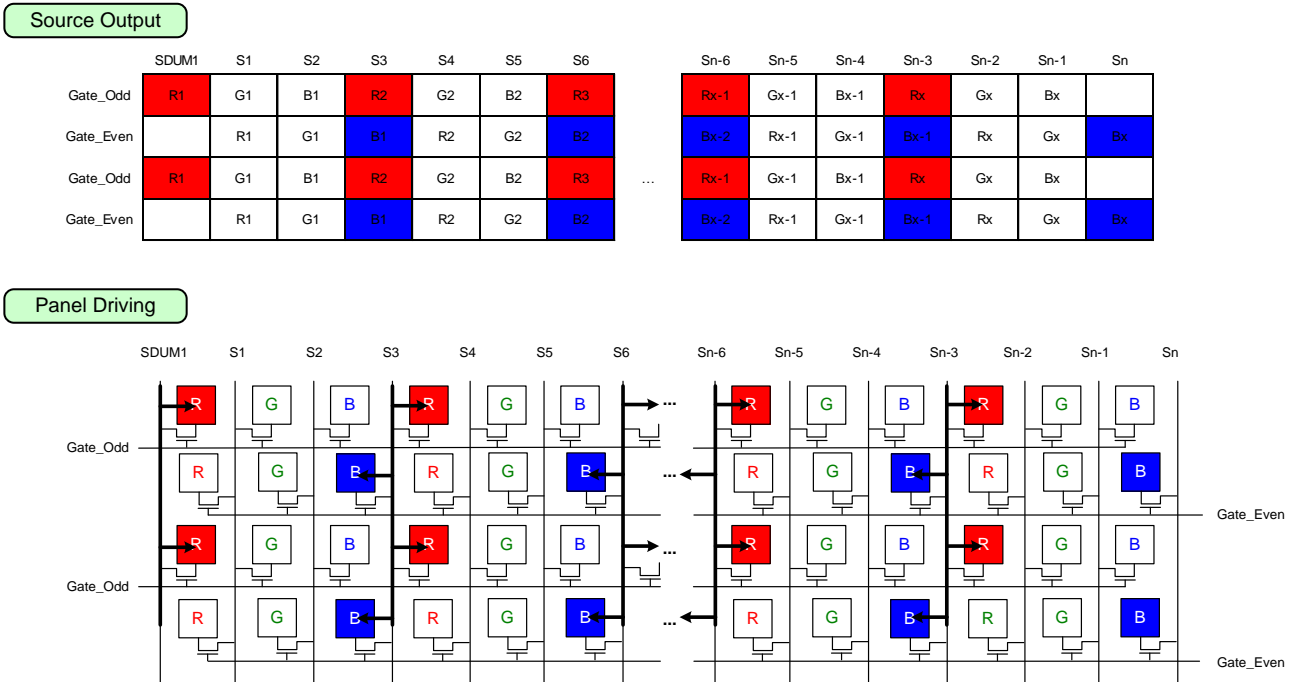

The figure below is the Zig-zag inversion panel driving method. The panel will be driven by the Red data input of the Gate_Odd and the Green data input of the Gate_Even.

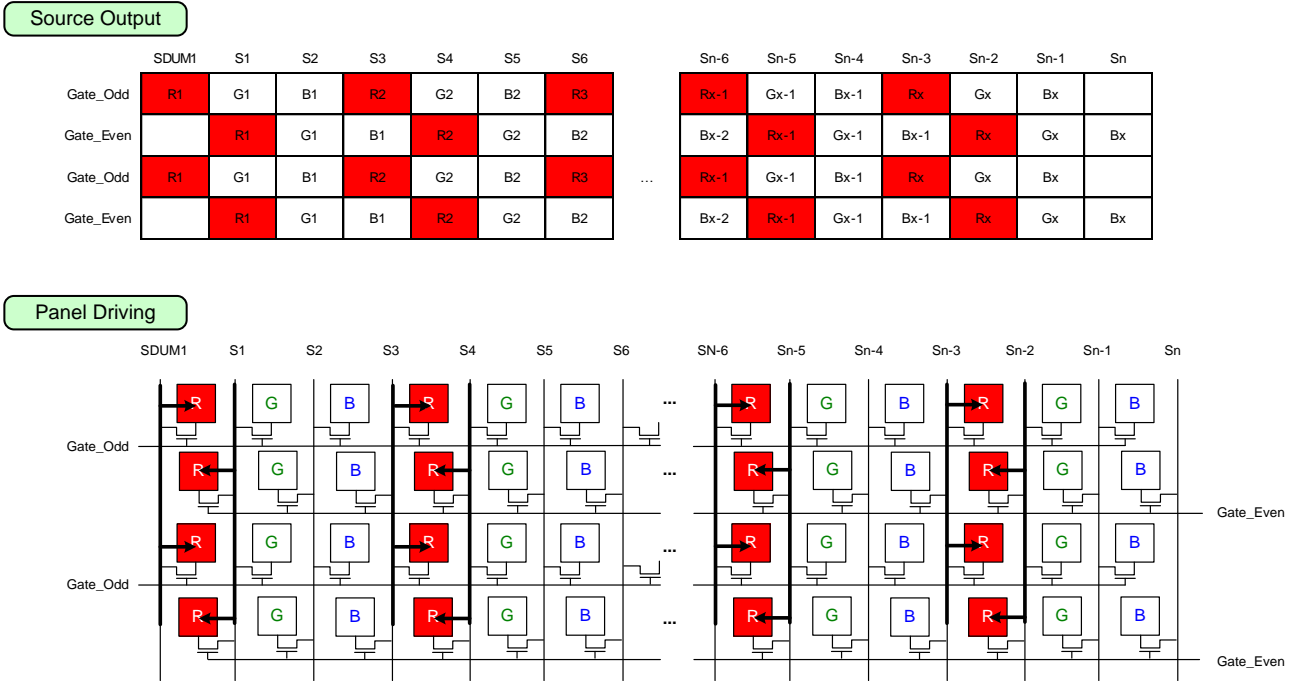

6.5. Zig-zag Inversion GREEN Data Display

The figure below illustrates the Zig-zag inversion panel driving method for Green data input.

When driving a Green pattern, the Green and Red sub-pixels will light up line by line according to the data signal input.

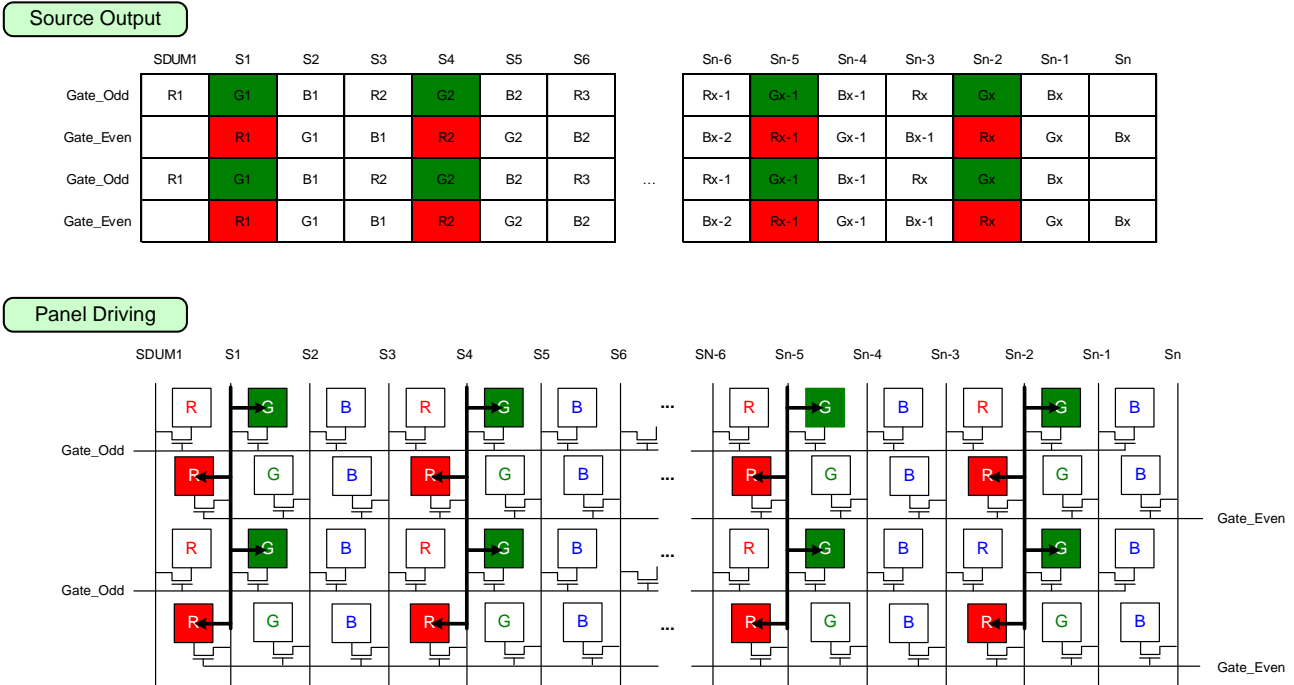

The figure below is the Zig-zag inversion panel driving method. The panel will be driven by the Green data input of the Gate_Odd and the Blue data input of the Gate_Even.

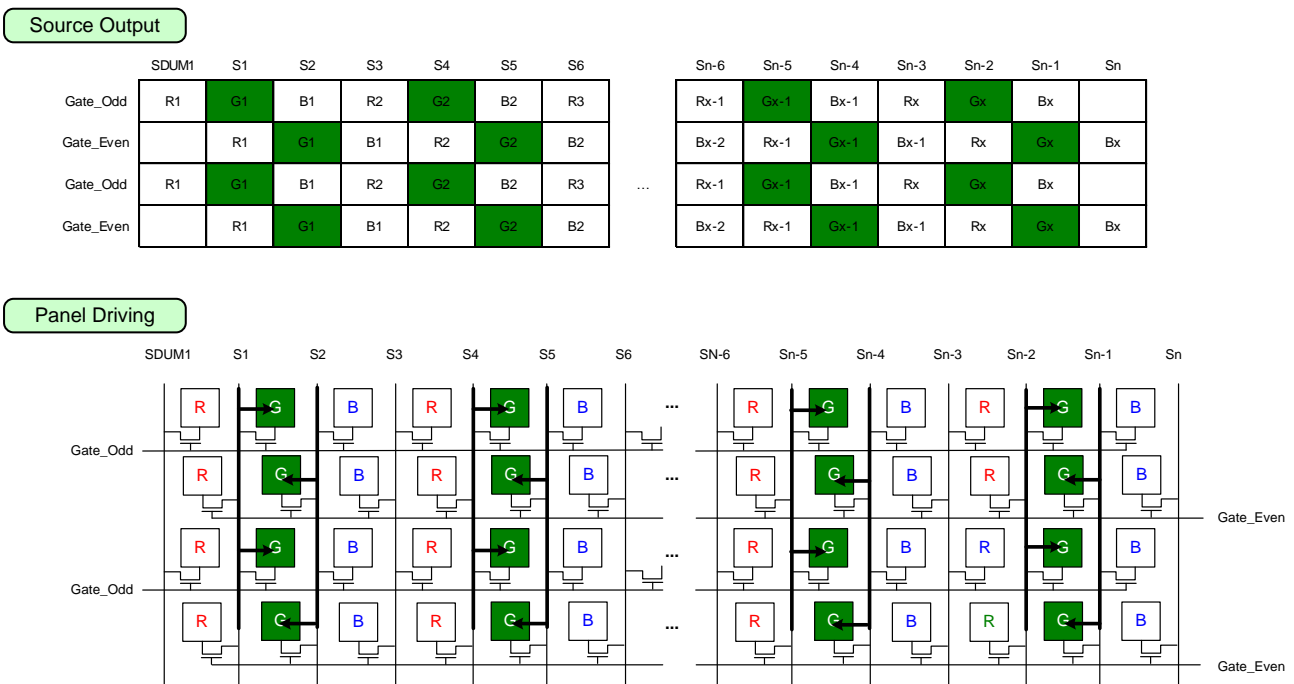

6.6. Zig-zag Inversion BLUE Data Display

The figure below illustrates the Zig-zag inversion panel driving method for Blue data input.

When driving a Blue pattern, the Blue and Green sub-pixels will light up line by line according to the data signal input.

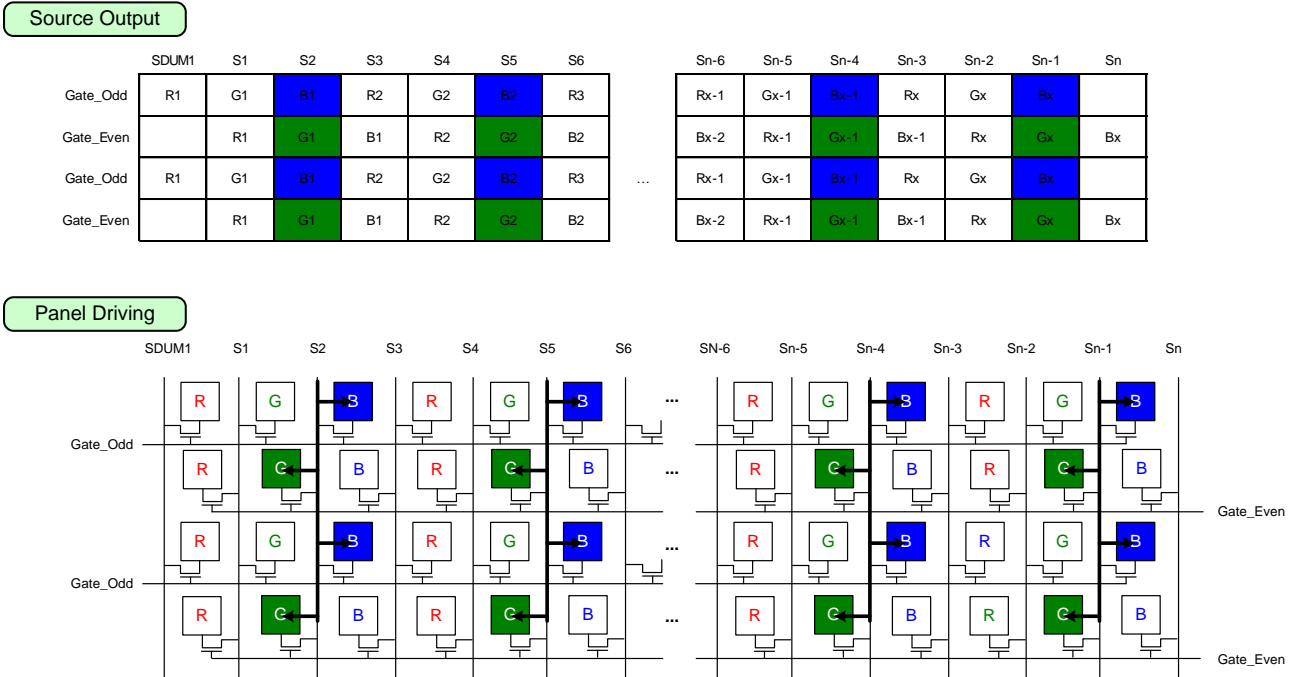

The figure below is the Zig-zag inversion panel driving method. The panel will be driven by the Blue data input of the Gate_Odd and the Red data input of the Gate_Even.

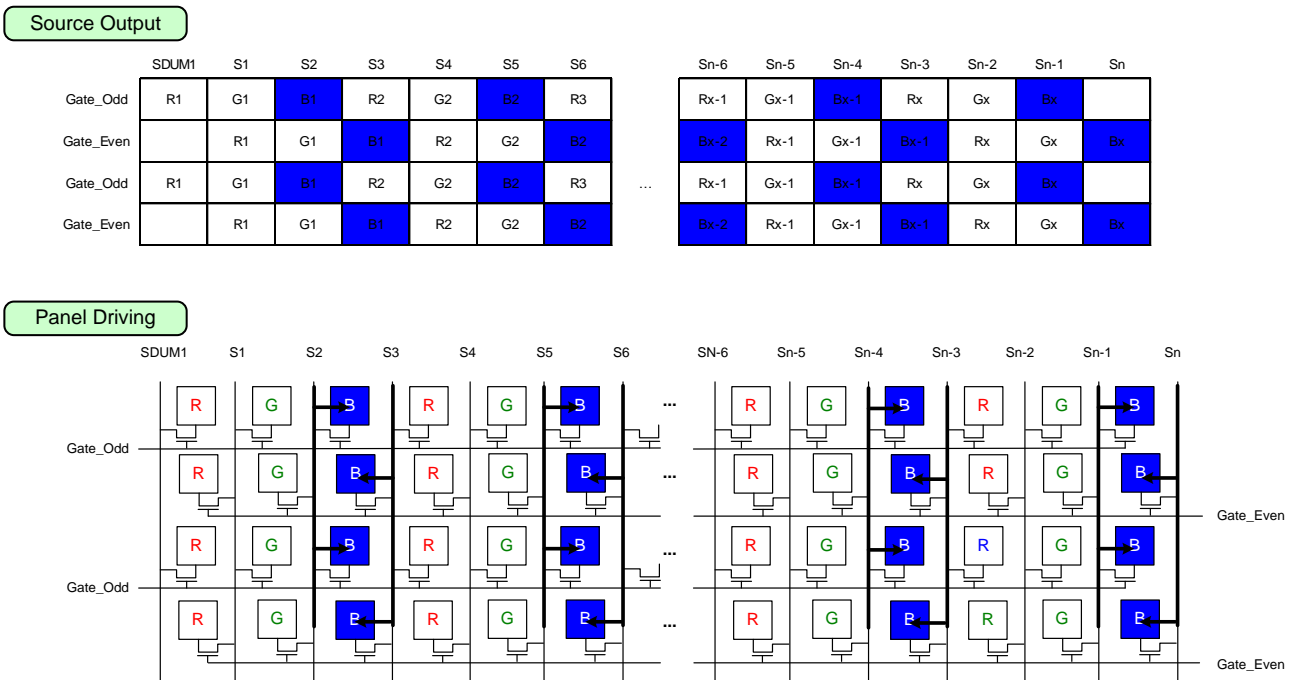

6.7. Different Zig-zag Type Panel

Zig-zag Type 1 (DINV[3:0] = 9h)

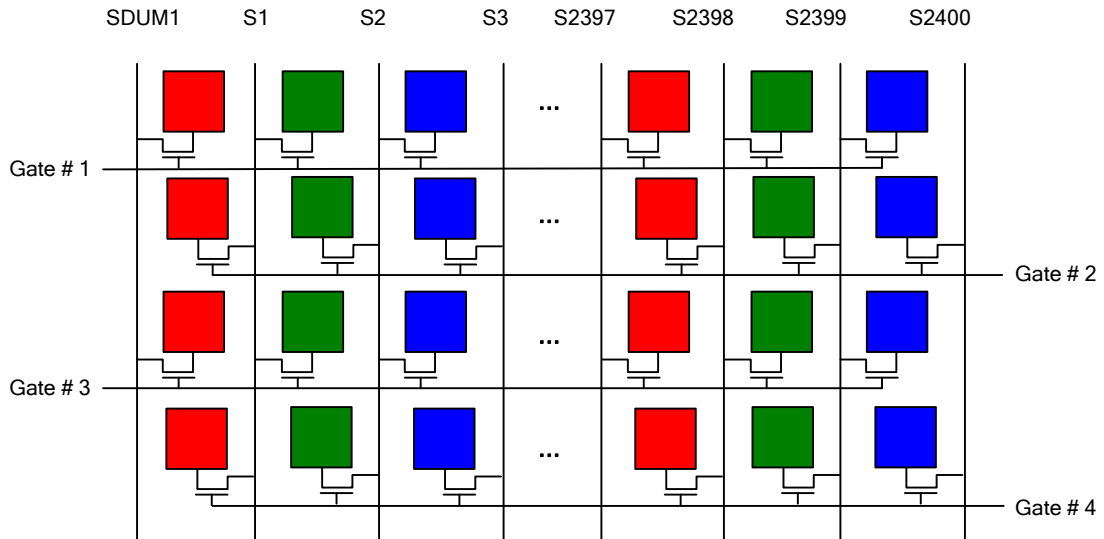

Zig-zag Type 2 (DINV[3:0] = Ah)

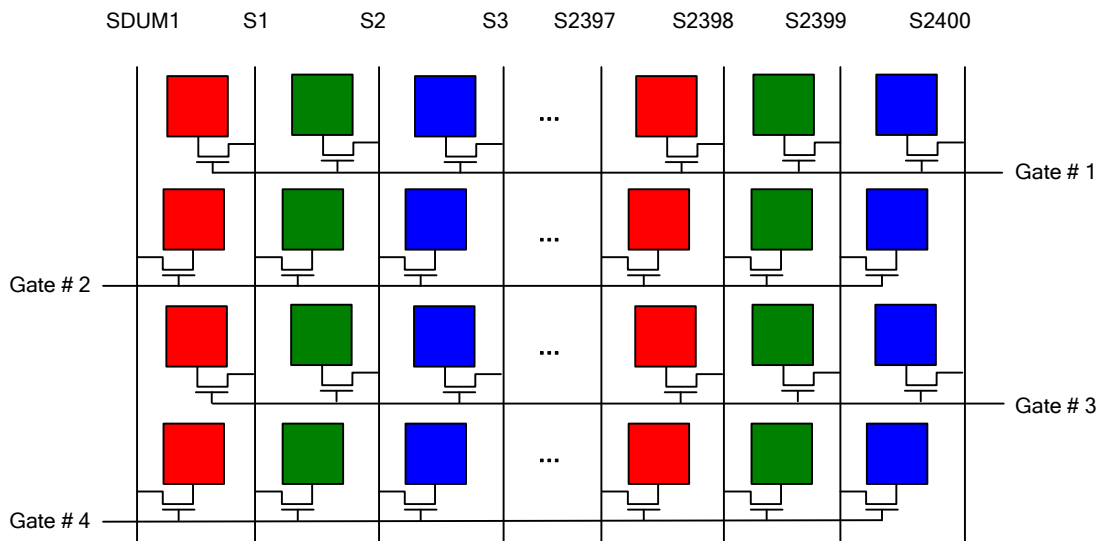

Zig-zag Type 3 (DINV[3:0] = Bh)

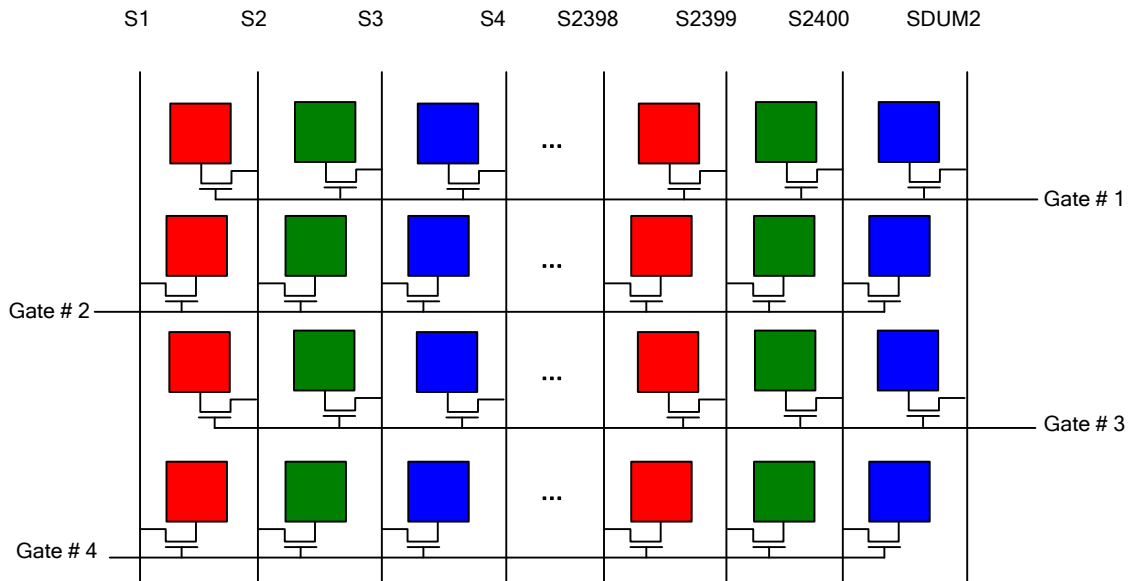

Zig-zag Type 4 (DINV[3:0] = Ch)

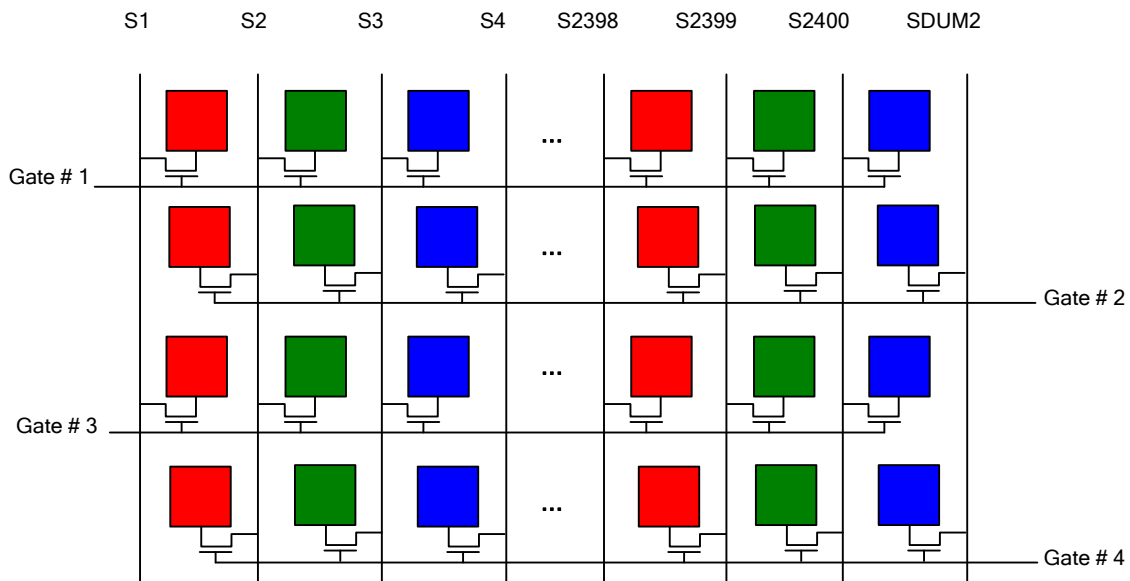

7. Enter/Exit Idle Mode Flow

7.1. Enter/Exit Idle Mode Flow

Input data format in Idle Mode shall use uncompressed 24 bit/pixel Writing and full-frame pixel data are carried in command mode using Memory Write Start and Memory Write Continue commands.

Following figure describes sequence to enter Idle Mode .

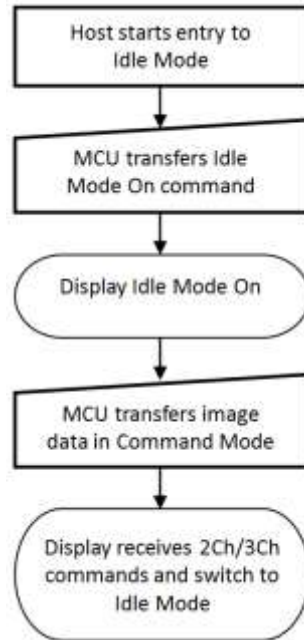

Figure 92: Enter Idle Mode Flow

Following figure describes sequence to exit Idle Mode and switch back to Video Mode operation.

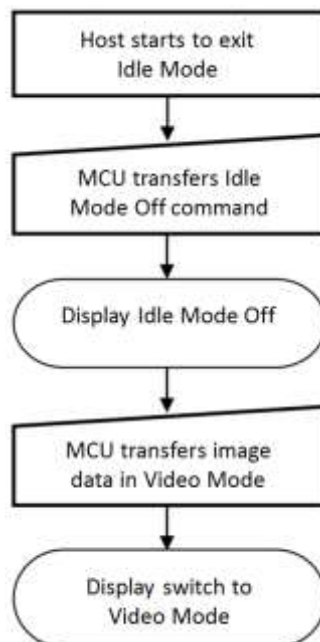

Figure 93: Exit Idle Mode Flow

7.2. Enter/Exit Idle Mode sequence

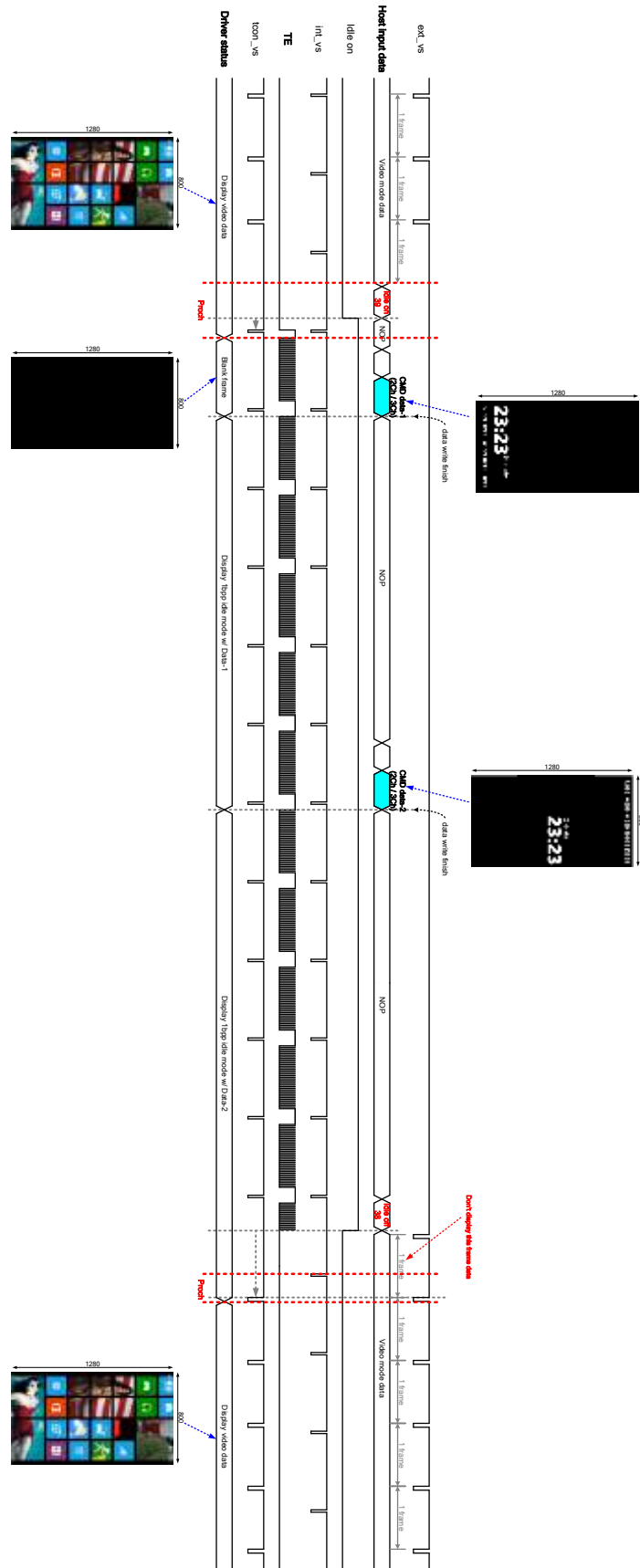
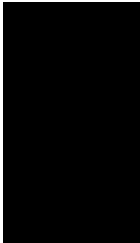
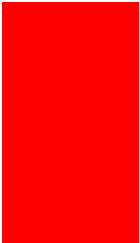
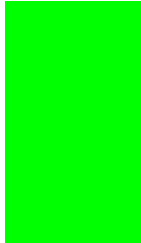
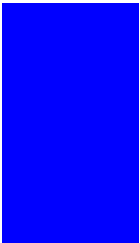
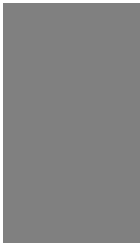

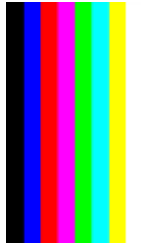

Figure 94: Enter/Exit Idle Mode Sequence

8. BIST Mode Function

8.1. BIST Mode Pattern

Table 33: BIST Mode Pattern

FRM_PT[0] White	FRM_PT[1]  Black	FRM_PT[2]  Red	FRM_PT[3]  Green
FRM_PT[4]  Blue	FRM_PT[5]  Gray128	FRM_PT[6]  Gray127	FRM_PT[7]  V-Color bar

9. Content Adaptive Brightness Control (CABC) Function

The CABC, a dynamic backlight control function, drastically reduces the power consumption of the luminance source. The ILI9881C-0D will refer the gray scale content of the display image to output in PWM waveform then to the LED driver for backlight brightness control. The content of gray scale can be increased while simultaneously lowering the brightness of the backlight to achieve the same perceived brightness. The adjusted gray level scale and the power consumption reduction depend on the content of the image.

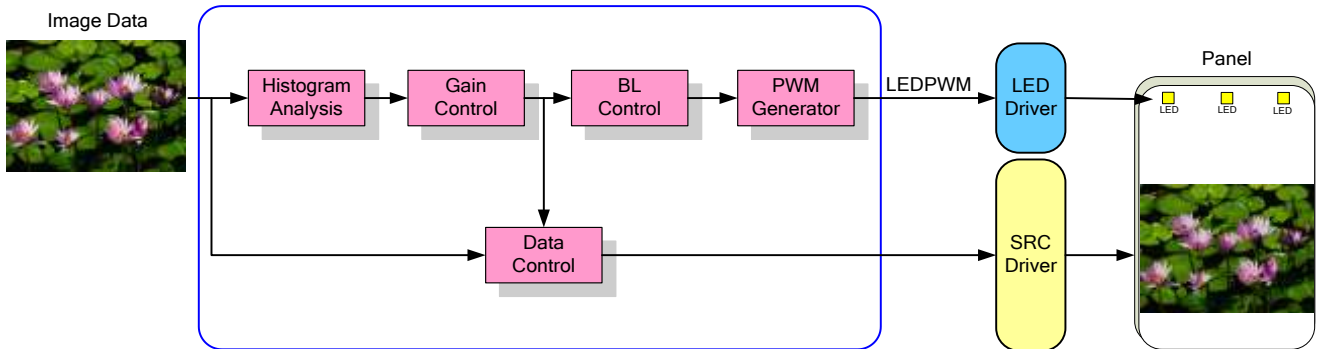

Figure 95: CABC Block Diagram

The ILI9881C-0D can calculate the backlight brightness level and send a PWM_OUT pulse to the LED driver via LEDPWM pin for backlight brightness control purposes. The PWM frequency can be adjusted by PWM_DIV parameters, and the calculating equation is shown below:

$$f_{LEDPWM} = \frac{32 \text{ MHz}}{(\text{PWM_DIV}[7:0] + 1) \times \text{PWM_DUTY_PRECISION}}$$

Figure 96 is the basic timing diagram which is applied from the ILI9881C-0D in order to control the LED driver.

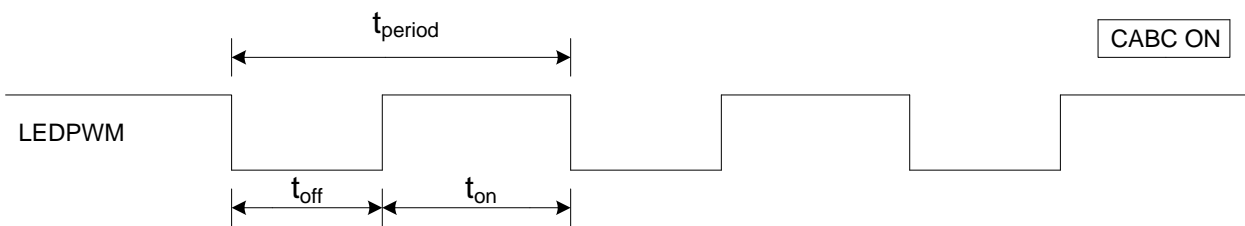

Figure 96: PWM OUT On/Off Period

10. Color Enhancement Function

10.1. Saturation Enhancement

The ILI9881C-0D provides the saturation enhancement to make the image content more vivid. The main concept in this feature is to enhance the color information on HSL domain, which includes the saturation information of each different color, show as Figure 97.

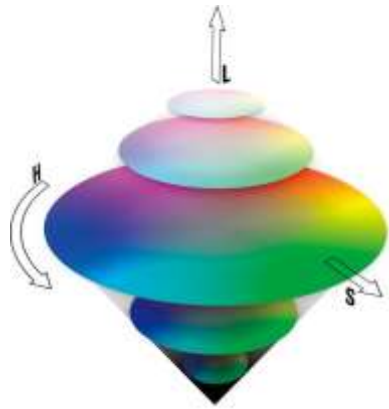

Figure 97: Saturation Enhancement : HSL model

In Figure 98, there is an example for saturation enhancement. Different enhancement levels being applied in this example.



Figure 98: Saturation Enhancement Image (a) Original, (b) Low Level, (c) Medium Level, (d) High Level.

10.2. Contrast Enhancement

The contrast between the dark and light, indicate the clarity of the image content. In this design, it provides contrast enhancement to increase the difference between dark and light to achieve the high contrast image. The user can select the enhancement level by setting command, the example shows below.

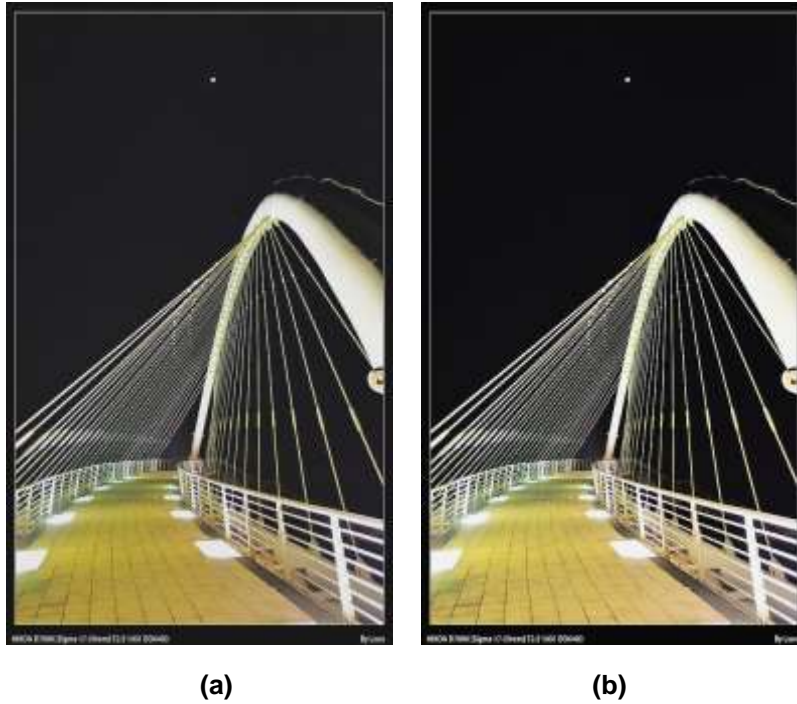

Figure 99: Contrast Enhancement Image (a) Original, (b) After enhancement

10.3. Sharpness Enhancement

Sharpness enhancement is provided to enhance the image visibility. Unlike contrast enhancement, sharpness enhancement is to strengthen the object's edge to make the object more clearly. The user can select the enhancement level by setting command, the example shows below.

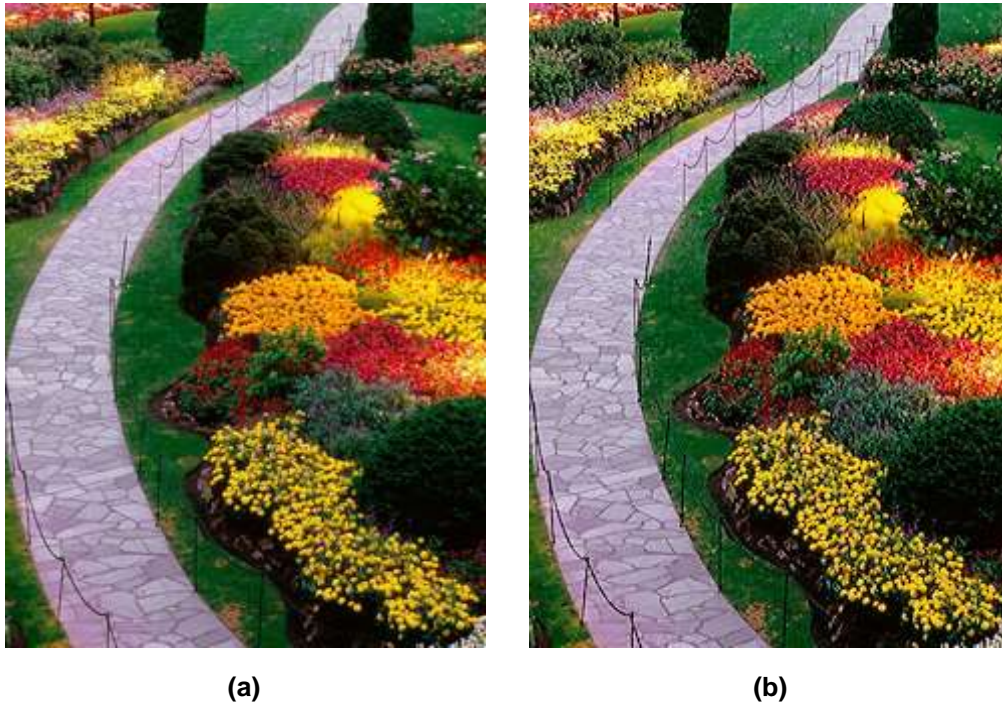

Figure 100: Sharpness Enhancement Image (a) Original, (b) After enhancement

10.4. Sunlight Readability

The sunlight readability is in order to achieve high visibility in daylight or other bright light condition. Figure 101 shows the main concept of the influence of ambient light to the LCD displayer and the solution in the high ambient light condition. In this design, it changes the image content to achieve the high visibility in the ambient light condition as shows in Figure 101(b).

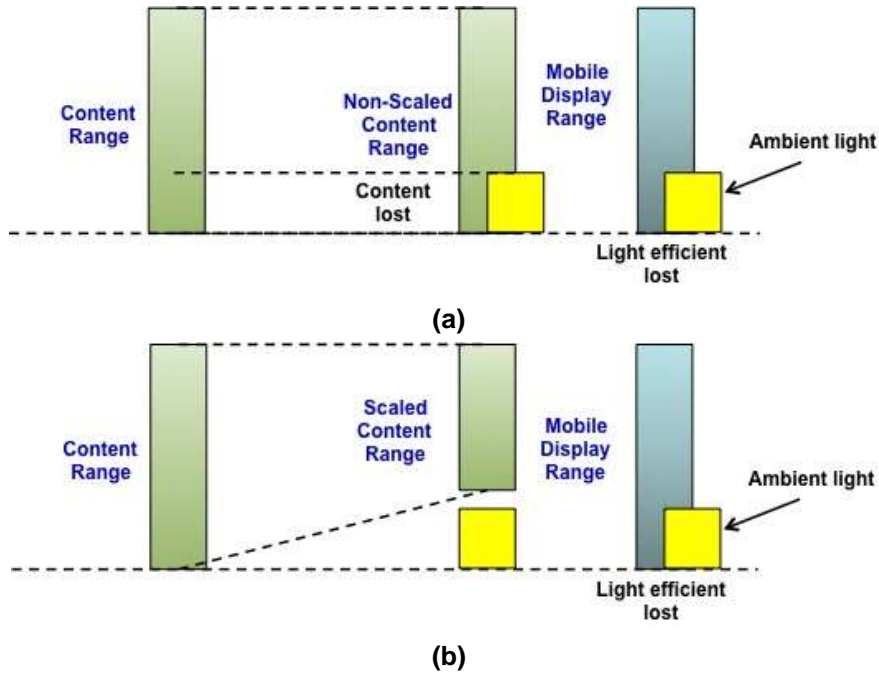

Figure 101: Sunlight Readability Concept (a) Backlight efficiency is consumed by ambient light, (b) Enhance the image content to avoid the influence.

11. Sleep Out Command and Self-Diagnostic Functions

11.1. Register Loading Detection

Sleep Out command (See Sleep Out (11h)) is a trigger for an internal function of the display module, which indicates, if the display module loading function of factory default values from EEPROM (or similar device) to registers of the display controller works properly.

The display controller will compare factory values of the EEPROM and register values of the display controller (1st step: compare register and EEPROM values; 2nd step: load EEPROM value to the register). If those two values (EEPROM and register values) are the same, a bit is inverted (= increased by 1), which is defined in command Read Display Self-Diagnostic Result (0Fh) (= RDDSDR) (The used bit of this command is D7). If those values are not the same, this bit (D7) is not inverted (= not increased by 1). The flow chart for this internal function is as follows:

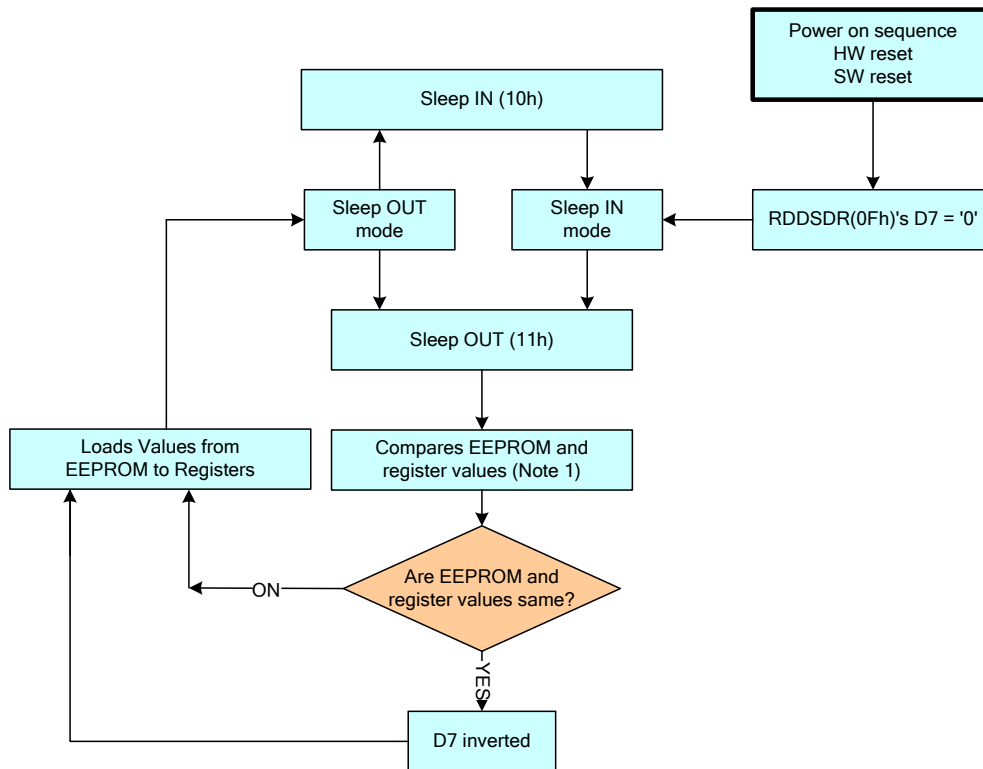

Figure 102: Register Loading Detection

Notes: If the EEPROM and loaded register values are not compared, then they can be changed by 00h to AFh and DAh to DDh commands.

11.2. Functionality Detection

The Sleep Out command (See Sleep Out (11h)) is a trigger for an internal function of the display module. It indicates if the display module is still running and meets functionality requirements. The internal function (the display controller) is compared to check if the display module still meets functionality requirements (e.g. booster voltage levels, timings, etc.). If functionality requirements are met, a bit is inverted (= increased by 1), defined in the command Read Display Self-Diagnostic Result (0Fh) (RDDSDR) (The used bit of this command is D6). If functionality requirement is not the same, this bit (D6) is not inverted (= not increased by 1). The flow chart for this internal function is as follows:

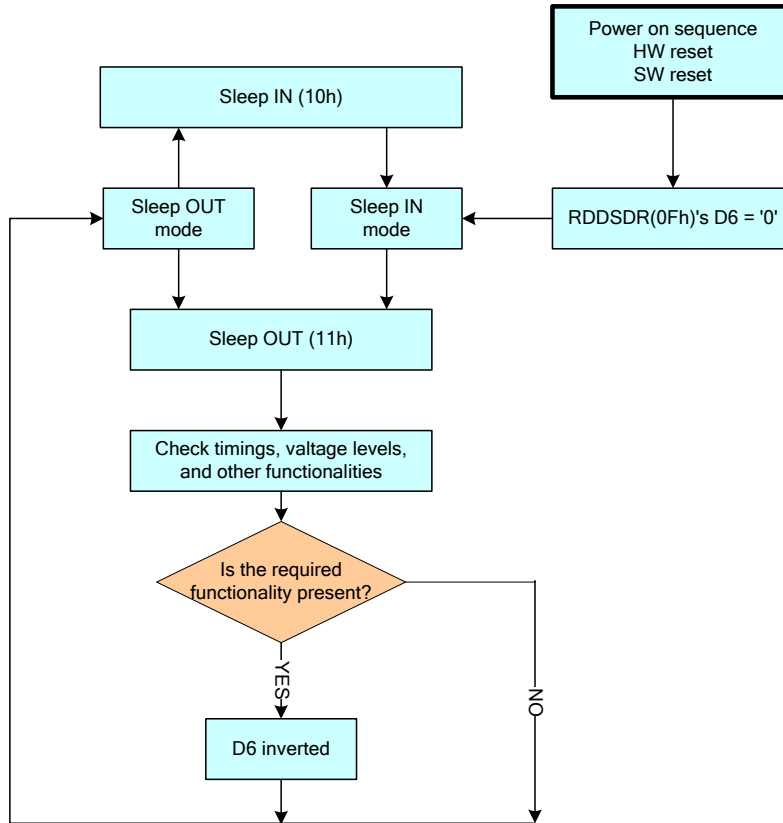

Figure 103: Functionality Detection

Notes: When changing from the Sleep In mode to Sleep Out mode, 120msec are needed after the Sleep Out command before it is able to check if functionality requirements are met and a value of RDDSDR's D6 is valid. Otherwise, there will be 5msec delay for the D6's value to be valid when the Sleep Out command is sent in the Sleep Out mode.

12. Power on/off Sequence

12.1. Power on/off sequence

12.1.1. Power Mode 2A

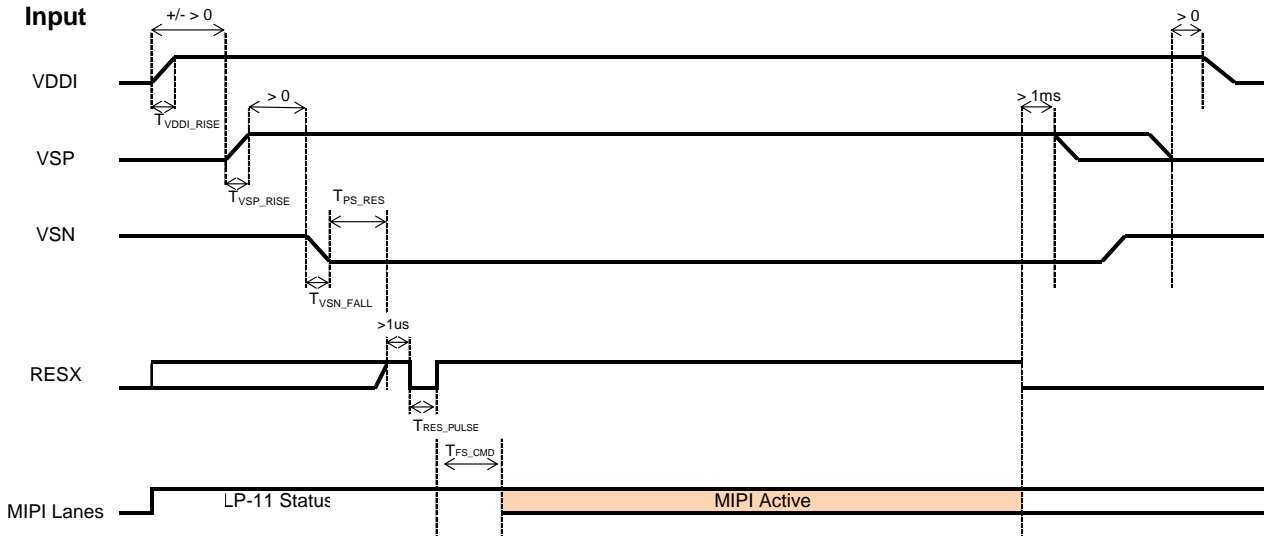

Symbol	Characteristics	Min.	Typ.	Max.	Units
T_{VDDI_RISE}	VDDI Rise time	10	-	-	us
T_{VSP_RISE}	VSP Rise time	130	-	-	us
T_{VSN_FALL}	VSN Fall time	200	-	-	us
T_{PS_RES}	VDDI/VSP on to Reset high	5	-	-	ms
T_{RES_PULSE}	Reset low pulse time	10	-	-	us
T_{FS_CMD}	Reset to first command	10	-	-	ms

Figure 104: Power on/off sequence with Power Mode 2A

12.1.2. Power Mode 3

Case A:

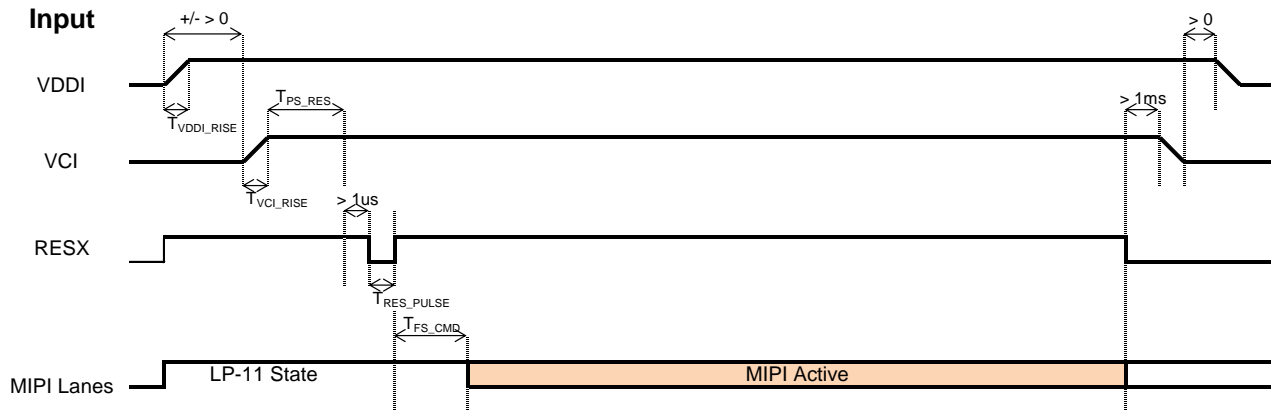

Case B:

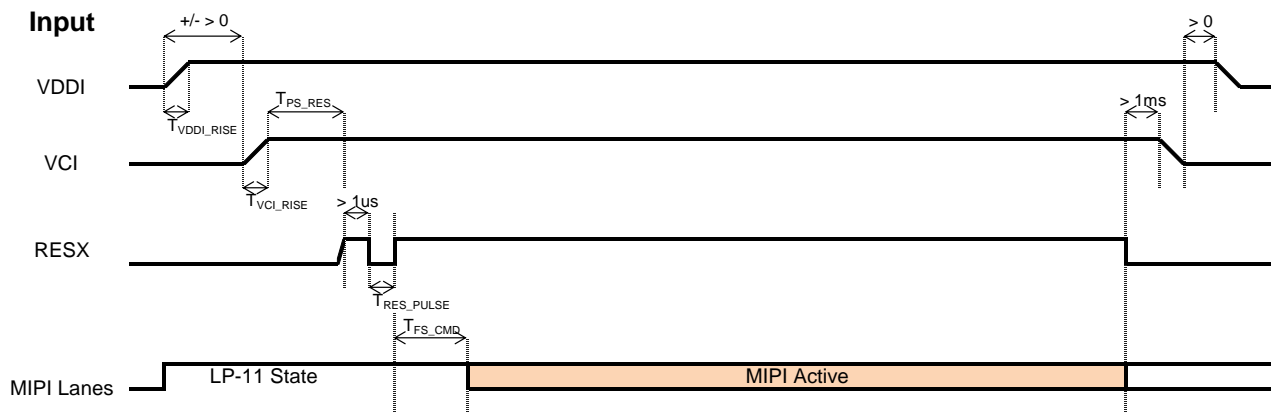

Symbol	Characteristics	Min.	Typ.	Max.	Units
T_{VDDI_RISE}	VDDI Rise time	10	-	-	us
T_{VCI_RISE}	Case A: VCI Rise time	130	-	-	us
	Case B: VCI Rise time	40	-	-	us
T_{PS_RES}	VDDI/VCI on to Reset high	5	-	-	ms
T_{RES_PULSE}	Reset low pulse time	10	-	-	us
T_{FS_CMD}	Reset to first command	10	-	-	ms

Figure 105: Power on/off sequence with Power Mode 3

12.1.3. Power Mode 4

Case A

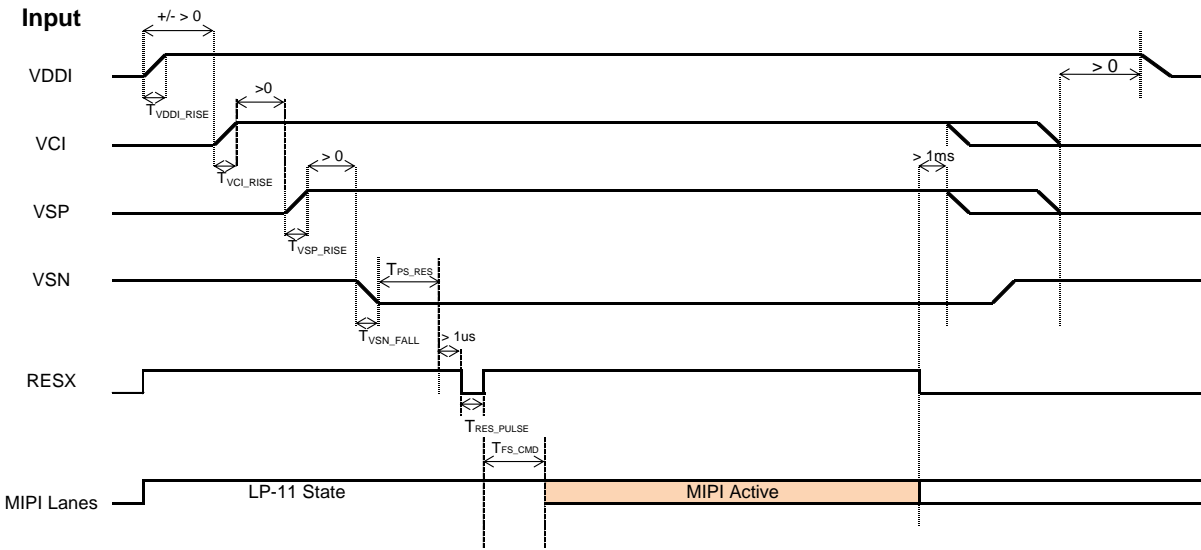

Case B

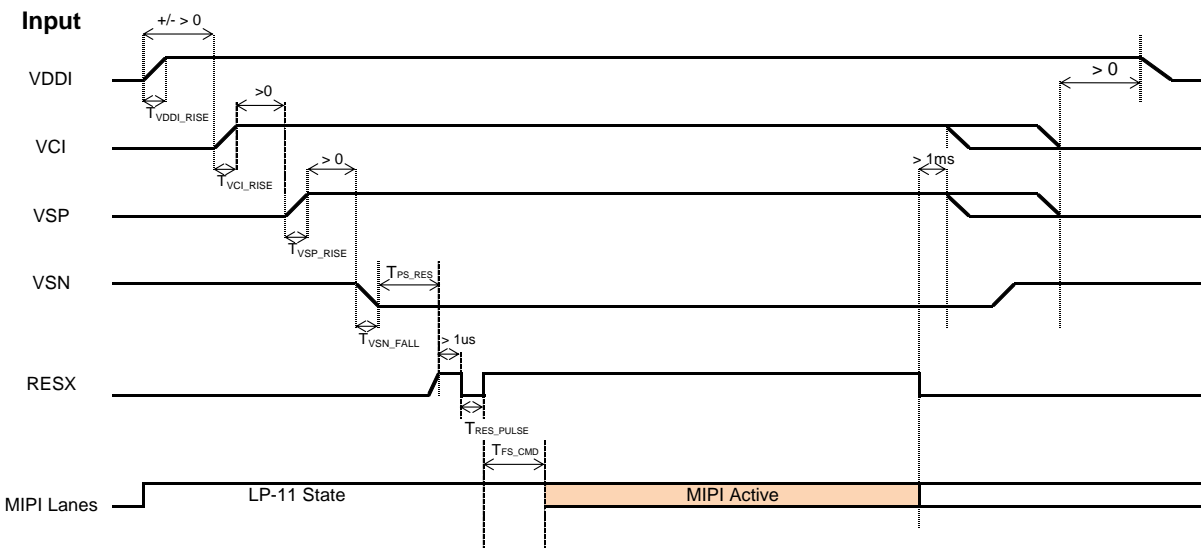

Symbol	Characteristics	Min.	Typ.	Max.	Units
T_{VDDI_RISE}	VDDI Rise time	10	-	-	us
T_{VCI_RISE}	Case A: VCI Rise time	130	-	-	us
	Case B: VCI Rise time	40	-	-	us
T_{VSP_RISE}	VSP Rise time	130	-	-	us
T_{VSN_FALL}	VSN Fall time	200	-	-	us
T_{PS_RES}	VDDI/VCI on to Reset high	5	-	-	ms
T_{RES_PULSE}	Reset low pulse time	10	-	-	us
T_{FS_CMD}	Reset to first command	10	-	-	ms

Figure 106: Power on/off sequence with Power Mode 4

12.2. Uncontrolled Power Off

The uncontrolled power off means a situation when a battery is removed without the controlled power off sequence. There will not be any damages for the display module, or the display module will not cause any damages for the host or lines of the interface. At an uncontrolled power off event, the ILI9881C-0D will force the display to become blank and will not have any abnormal visible effects within 1 second on the display and remains blank until the Power On Sequence powers it up.

13. Power Level Definition

13.1. Power Levels

4 level modes are defined in order from Maximum to Minimum Power consumption:

1. Normal Mode On (full display), Sleep Out, Idle Mode Off.
In this mode, the display is able to show a maximum of 16.7M colors.
2. Normal Mode On (full display), Sleep Out, Idle Mode On.
In this mode, the display is able to show a maximum of 2 colors.
3. Sleep In Mode.
In this mode, the DC/DC converter, internal oscillator and panel driver circuit are stopped.
4. Power Off Mode.
In this mode, all input powers are removed.

Transition between modes 1-3 is controllable by MCU commands. Mode 4 is entered only when both Power supplies are removed.

13.2. Power Flow Chart

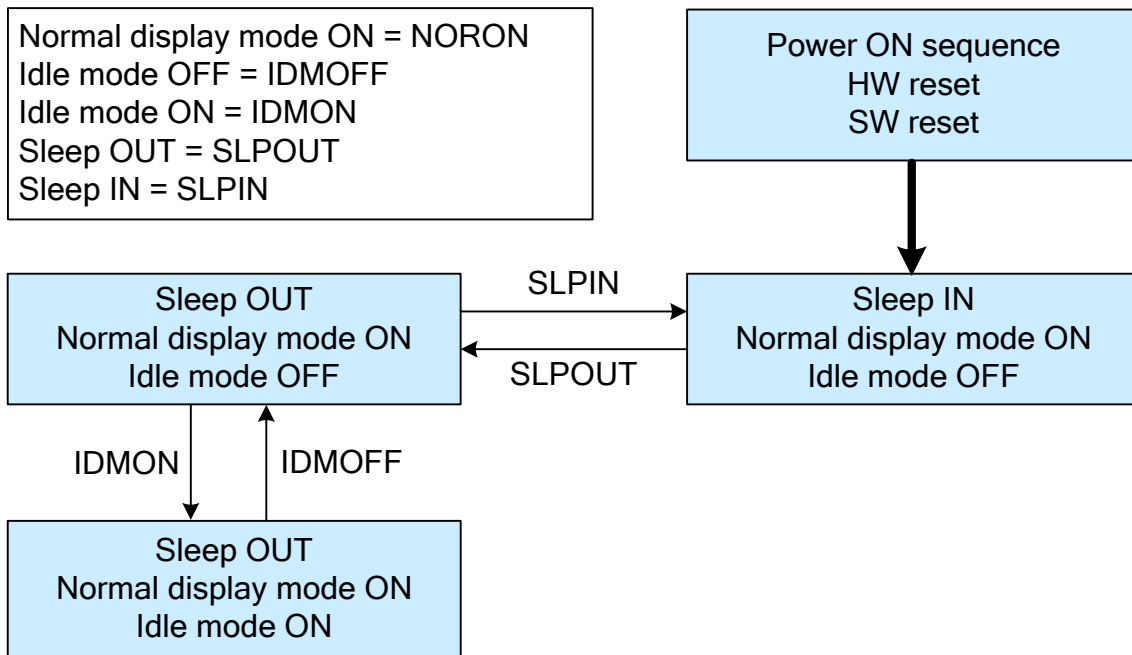

Figure 1075: Power Mode Flow Chart

Notes:

1. There is not any abnormal visual effect when one power mode changes to another power mode.
2. There is not any limitation, which is not specified by User, when one power mode changes to another power mode.

14. Characteristics of I/O

14.1. Output or Bi-directional (I/O) Pins

Table 34: Characteristics of Output or Bi-directional (I/O) Pins

Pin/Line	After Power ON	After Hardware Reset	After Software Reset
D0P	Hi-Z (Inactive)	Hi-Z (Inactive)	Hi-Z (Inactive)
D0N	Hi-Z (Inactive)	Hi-Z (Inactive)	Hi-Z (Inactive)
VS	Hi-Z (Inactive)	Hi-Z (Inactive)	Hi-Z (Inactive)
HS	Hi-Z (Inactive)	Hi-Z (Inactive)	Hi-Z (Inactive)
LEDPWM	Low	Low	Low
TE	Low	Low	Low

Note: There will be no output from D0P, D0N, VS, HS, LEDPWM and TE during Power ON/OFF sequence, hardware reset, and software reset.

14.2. Input Pins

Table 35: Input Pins

Pin/Line	During Power ON Process	After Power ON	After Hardware Reset	After Software Reset	During Power OFF Process
RESX	See chapter 12	Input valid	Input valid	Input valid	See chapter 12
IM[2:0]	Input invalid	Input valid	Input valid	Input valid	Input invalid
LANSEL	Input invalid	Input valid	Input valid	Input valid	Input invalid
RS[1:0]	Input invalid	Input valid	Input valid	Input valid	Input invalid
BOOSTM[2:0]	Input invalid	Input valid	Input valid	Input valid	Input invalid
CLKP	Input invalid	Input valid	Input valid	Input valid	Input invalid
CLKN	Input invalid	Input valid	Input valid	Input valid	Input invalid
D0P	Input invalid	Input valid	Input valid	Input valid	Input invalid
D0N	Input invalid	Input valid	Input valid	Input valid	Input invalid
D1P	Input invalid	Input valid	Input valid	Input valid	Input invalid
D1N	Input invalid	Input valid	Input valid	Input valid	Input invalid
D2P	Input invalid	Input valid	Input valid	Input valid	Input invalid
D2N	Input invalid	Input valid	Input valid	Input valid	Input invalid
D3P	Input invalid	Input valid	Input valid	Input valid	Input invalid
D3N	Input invalid	Input valid	Input valid	Input valid	Input invalid

15. NV Memory Programming Flow

15.1. External MTP_PWR Programming Flow

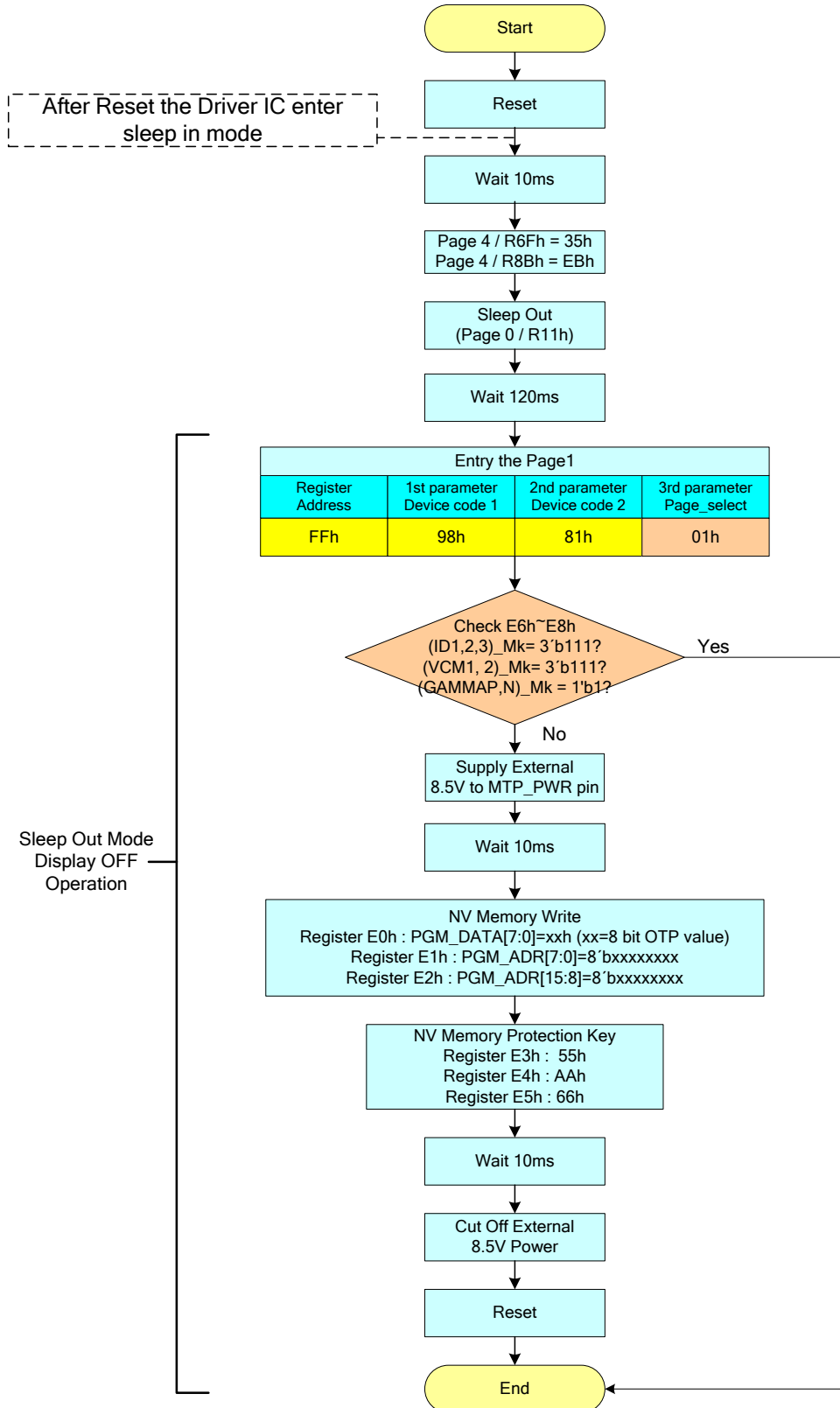
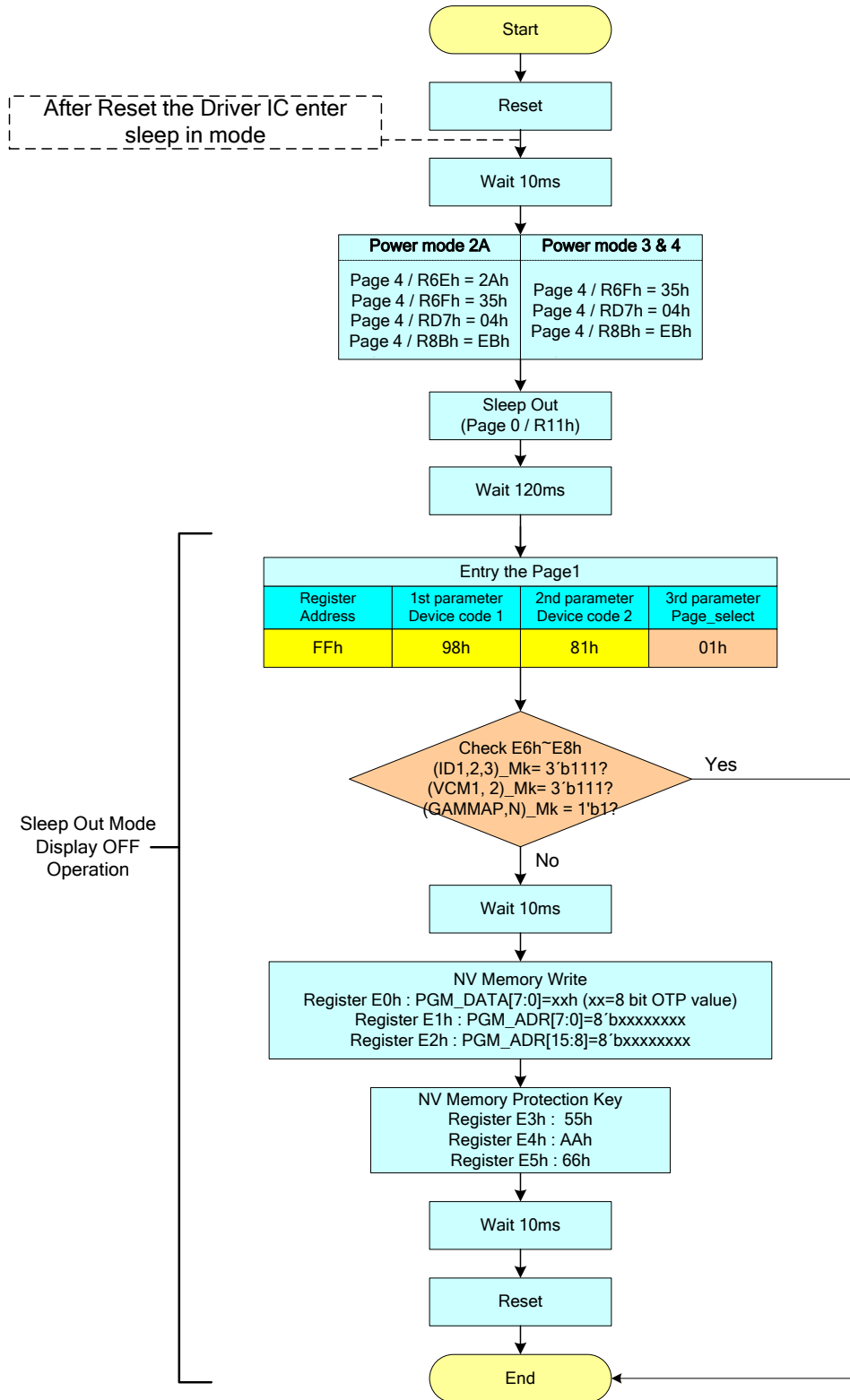

Figure 108: External MTP_PWR Programming Flow

15.2. Internal VGH Programming Flow



Note: Internal VGH Programming must operate in the Low Power mode.

Figure 109: Internal VGH Programming Flow

16. Gamma Correction

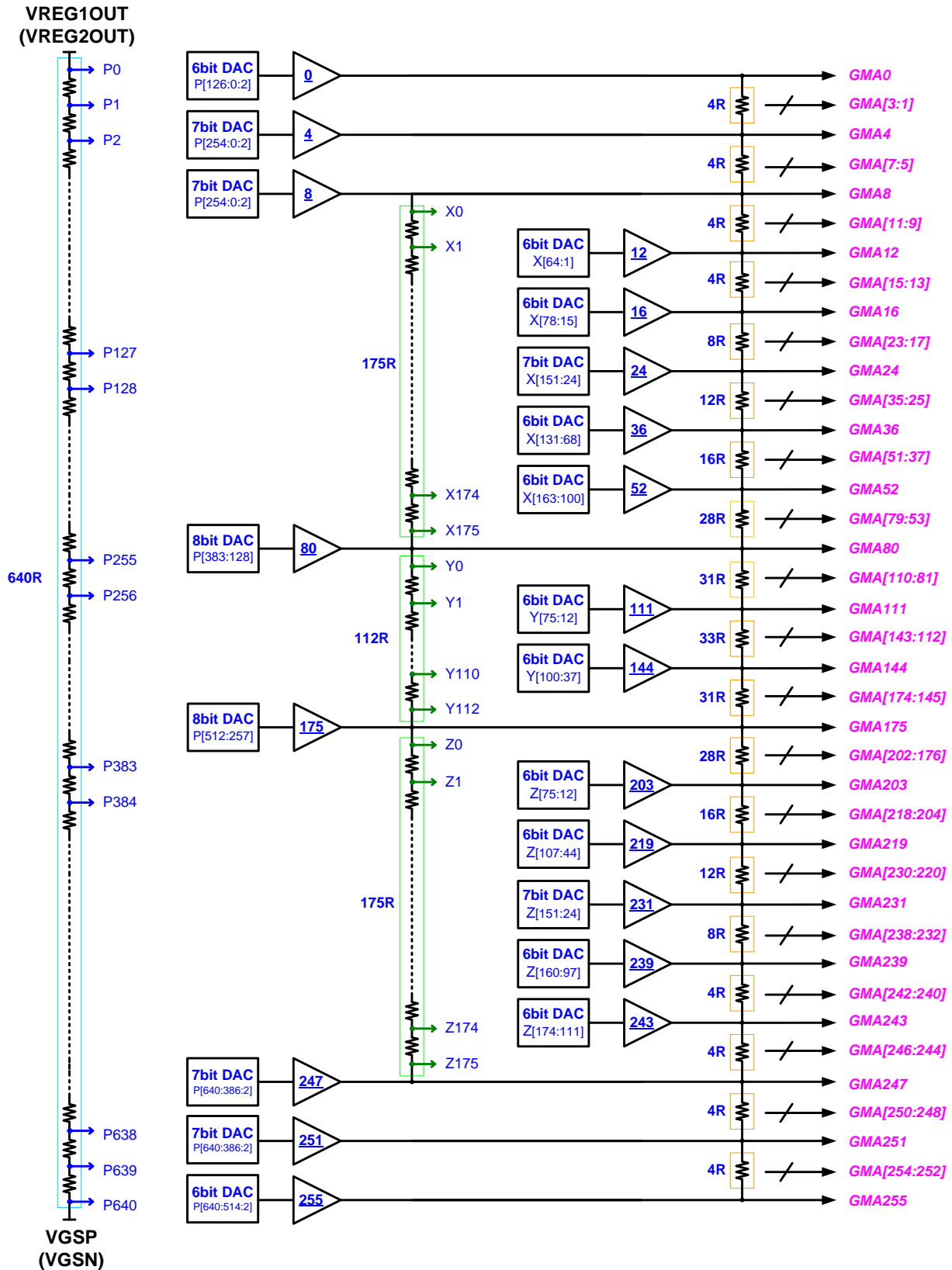

Figure 110: Gamma Architecture

17. Touch Synchronization Signal

The VS and HS pad of ILI9881C-0D can output the synchronization signals to touch sensing signal for touch panel controller. To use these signals, touch panel controller can receive touch sensing signal while avoiding display changing noise.

These signals are consist of vertical synchronization signal: VSOUT and horizontal synchronization signal: HSOUT. The level of output voltage is VDDI to GND. Each signal can adjust output timing for internal synchronization signal. The high level width of VSOUT is 1 line, and it is adjustable. VSOUT is outputted always, but HSOUT is outputted during displaying only.

(1) VSOUT output Timing

VSOUT output means internal VSYNC is starting point. VSOUT output timing can be adjusted by VSOD register. Unit is 1H.

(2) HSOUT output Timing

HSOUT output means internal source output timing is starting point. HSOUT output timing can be adjusted by HSOD register. And HSOUT high level width can be adjusted by HSOHW register.

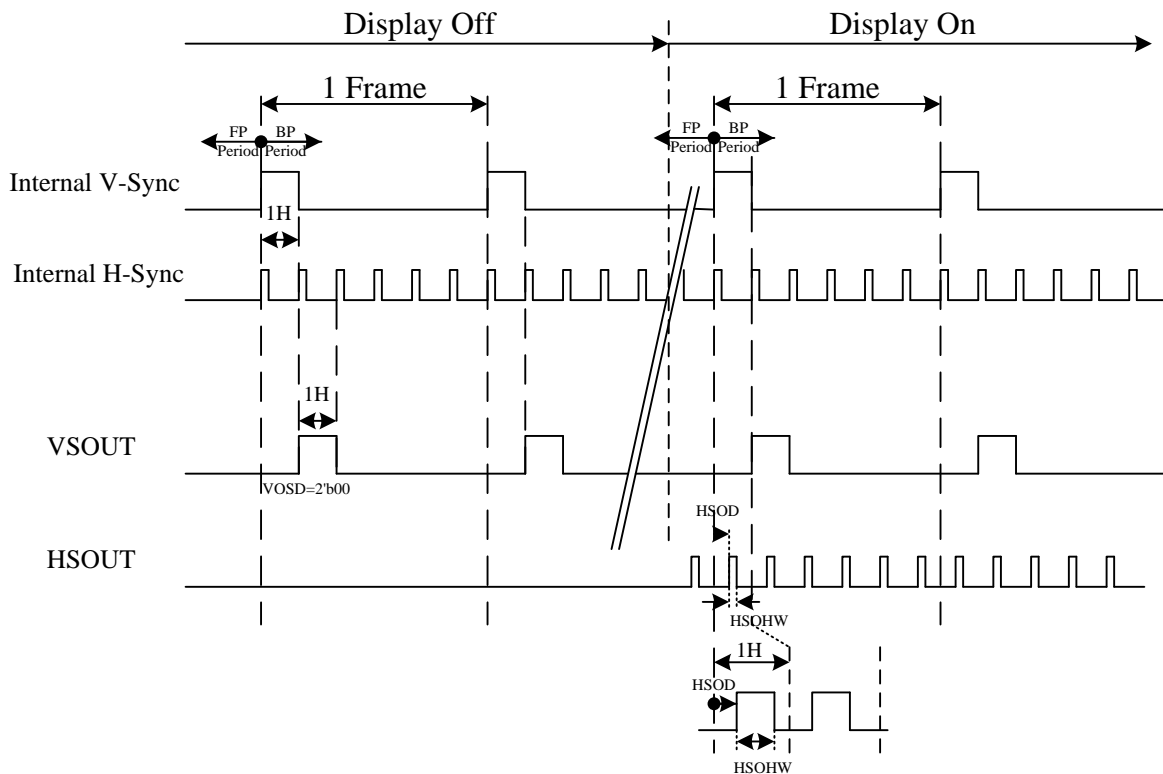

Figure 111: Touch Synchronization Signal

18. Electrical Characteristics

18.1. Absolute Maximum Ratings

The absolute maximum rating is listed in Table 36. When the ILI9881C-0D is used out of the absolute maximum ratings, it may be permanently damaged. To use the ILI9881C-0D within the following electrical characteristics limit is strongly recommended for normal operation. If these electrical characteristic conditions are exceeded during normal operation, the ILI9881C-0D will malfunction and cause poor reliability.

Table 36: Absolute Maximum Ratings

Item	Symbol	Unit	Value
Analog Operating Voltage	VCI ~ GND	V	-0.3 ~ +7.0
Analog Operating Voltage	VCIREF ~ GND	V	-0.3 ~ +7.0
Digital Operating Voltage	VDDI ~ GND	V	-0.3 ~ +3.8
Digital Operating Voltage	VCC1 ~ GND	V	-0.3 ~ +7.0
Digital Operating Voltage	VCC2 ~ GND	V	-0.3 ~ +7.0
DSI Operating Voltage	VDDAM ~ GND	V	-0.3 ~ +3.8
OTP Supply Voltage	MTP_PWR ~ GND	V	-0.3 ~ +9.0
Supply Voltage	VSP ~ GND	V	-0.3 ~ +7.0
Supply Voltage	VSN ~ GND	V	0.3 ~ -7.0
Gate Driver High Voltage	VGH ~ GND	V	-0.3 ~ +18
Gate Driver Low Voltage	VGL ~ GND	V	0.3 ~ -18
Driver Supply Voltage	VDDI - VCL	V	≤ 6.6V
Driver Supply Voltage	VGH - VGL	V	≤ 32.0V
Input Voltage	VIN	V	-0.3 ~ VDDI + 0.3
HS Input Voltage	VHSIN	V	-0.3 ~ + 1.65
Operating Temperature	Topr	°C	-30 ~ +70
Storage Temperature	Tstg	°C	-55 ~ +110

Note: Even if the absolute maximum rating of one of the above parameters is exceeded only for a short while, the quality of the product may be degraded. Therefore, be sure to use the product within the range of the absolute maximum ratings.

18.2. DC Characteristics for Panel Driving

Item	Symbol	Condition	Min.	Typ.	Max.	Unit	Note
Power & Operation Voltage							
Analog operating voltage	VCI	-	2.5	2.8	6.6	V	
Analog operating voltage	VCIREF		2.5	2.8	6.6	V	
Digital operating voltage	VDDI	-	1.65	2.8	3.6	V	
Digital operating voltage	VCC1		1.65	2.8	6.6	V	
Digital operating voltage	VCC2		1.65	2.8	6.6	V	
DSI operating voltage	VDDAM	-	1.65	1.8	3.6	V	
OTP Supply voltage	MTP_PWR	-	8.4	8.5	8.6	V	
Analog operating voltage	VSP	-	4.5		6.6	V	
Analog operating voltage	VSN	-	-6.6		-4.5	V	
Logic High level input voltage	VIH	-	0.7*VDDI		VDDI	V	Note1
Logic Low level input voltage	VIL	-	-0.3		0.3*VDDI	V	Note1
Logic High level output voltage TE , LEDPWM	VOH	IOH = -1.0mA	0.8*VDDI		VDDI	V	Note1
Logic Low level output voltage TE , LEDPWM	VOL	IOL = +1.0mA	0		0.2*VDDI	V	Note1
Gate Driver High Voltage	VGH	-	8.0	-	18	V	
Gate Driver Low Voltage	VGL	-	-18.0	-	-7.0	V	
Driver Supply Voltage	-	VGH-VGL	15	-	32	V	
VCOM Operation							
DC VCOM Amplitude Voltage	VCOM	-	-4.0	-	0	V	Note3
Source Driver							
Source Output Range	VSOUT(+)	-	0.3	-	VREG1OUT-0.1	V	Note4
	VSOUT(-)	-	VREG2OUT +0.1	-	-0.3	V	Note4
Positive Gamma Reference Voltage	VREG1OUT	-	3.5	-	VSP-0.5 (VSP<=6.1) 5.6 (VSP>6.1)	V	
Negative Gamma Reference Voltage	VREG2OUT	-	VSN+0.5 (VSN>=-6.1) -5.6 (VSN<-6.1)	-	-3.5	V	
Source Output Setting Time	Tr	Below with 99% precision	-	10	-	uS	Note3.4
Output Deviation Voltage (Source Output channel)	Vdev	Sout>=4.2V Sout<=0.8V	-	-	20	mV	Note3
		4.2V>Sout>0.8V	-	-	15	mV	
Output Offset Voltage	VOFFSET	-	-	-	35	mV	Note3
Standby mode current consumption							
Sleep In mode	I(VDDI SLP IN)	Ta = 25 °C VCI=2.8V VDDI=1.8V	-	35	-	uA	
	I(VCI SLP IN)		-	25	-	uA	

Notes:

1. Ta = -30 to 70 °C (to 85 °C no damage) , VCI = 2.5V to 6.6V, VDDI = 1.65V to 3.6V
2. Supply digital VDDI voltage equal or less than analog VCI voltage.
3. Source channel loading = 9KΩ, 70pF/channel
4. The maximum value is between with Note 3 and Gamma setting value

18.3. DSI DC Characteristics

The DSI uses different state codes which depend on DC voltage levels of the clock and data lanes. The meaning of the state codes is defined in the following table.

State Code	Line DC Voltage Levels	
	CLOCK_P or DATA_P	CLOCK_N or DATA_N
HS-0	Low (HS)	High (HS)
HS-1	High (HS)	Low (HS)
LP-00	Low (LP)	Low (LP)
LP-01	Low (LP)	High (LP)
LP-10	High (LP)	Low (LP)
LP-11	High (LP)	High (LP)

Note: $T_a = -30^{\circ}\text{C}$ to 70°C (to $+85^{\circ}\text{C}$ no damage)

18.3.1. DC Characteristics for DSI LP Mode

DC levels of the LP-00, LP-01, LP-10 and LP-11 are defined in the table below: DC Characteristics for the DSI LP mode when LP-RX, LP-CD or LP-TX is mentioned in the condition column. Other logical levels in the table are for MCU interface.

Parameter	Symbol	Condition	Specification			Unit
			Min.	Typ.	Max.	
Logic 1 input voltage	V_{IHLPD}	LP-CD	450	-	1350	mV
Logic 0 input voltage	V_{ILLPCD}	LP-CD	0.0	-	200	mV
Logic 1 input voltage	V_{IHLPRX}	LP-RX (CLK, D0, D1, D2, D3)	880	-	1350	mV
Logic 0 input voltage	V_{ILLPRX}	LP-RX (CLK, D0, D1, D2, D3)	0.0	-	550	mV
Logic 0 input voltage	$V_{ILLPRXULP}$	LP-RX (CLK ULP mode)	0.0	-	300	mV
Logic 1 output voltage	V_{OHLPTX}	LP-TX (D0)	1.1	-	1.3	V
Logic 0 output voltage	V_{OLLPTX}	LP-TX (D0)	-50	-	50	mV
Logic 1 input current	I_{IH}	LP-CD, LP-RX	-	-	10	uA
Logic 0 input current	I_{IL}	LP-CD, LP-RX	-10	-	-	uA

Notes:

- $T_a = -30^{\circ}\text{C}$ to 70°C (to $+85^{\circ}\text{C}$ no damage)
- DSI High Speed mode is off.

18.3.2. Spike/Glitch Rejection

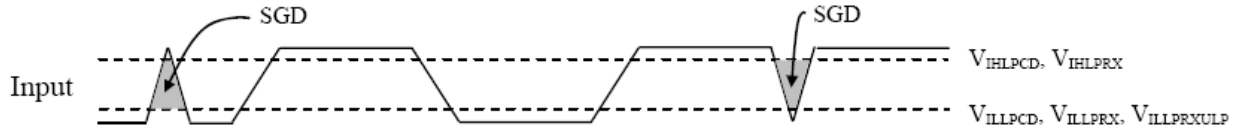

Figure 112: Spike/Glitch Rejection

Notes:

1. A spike/glitch can be rejected when the Peak Interference Amplitude is 200mV (at maximum) and Interference Frequency is 450MHz (at the very least).
2. $n = 0, 1, 2$ and 3.

Table 37: Spike/Glitch Rejection

Spike/Glitch Rejection – DSI					
Signal	Symbol	Parameter	Min	Max	Unit
CLKP/N, DnP/N	SGD	Input pulse rejection for DSI	-	300	Vps

18.3.3. DC Characteristics for DSI HS mode

Parameter	Symbol	Condition	Specification			Unit
Input Common Mode Voltage for Clock	V_{CMCLK}	CLKP/N Note 2, Note 3	70	-	330	mV
Input Common Mode Voltage for Data	V_{CMDATA}	DnP/N Note 2, Note 3, Note 5	70	-	330	mV
Common Mode Ripple for Clock Equal or Less than 450MHz	$V_{CMRCLKL450}$	CLKP/N Note 4	-50	-	50	mV
Common Mode Ripple for Data Equal or Less than 450MHz	$V_{CMRDATAL450}$	DnP/N Note 4, Note 5	-50	-	50	mV
Common Mode Ripple for Clock More than 450MHz (peak sine wave)	$V_{CMRCLKM450}$	CLKP/N	-	-	100	mV
Common Mode Ripple for Data More than 450MHz (peak sine wave)	$V_{CMRDATAM450}$	DnP/N Note 5	-	-	100	mV
Differential Input Low Level Threshold Voltage for Clock	$V_{THLCLK-}$	CLKP/N	-70	-	-	mV
Differential Input Low Level Threshold Voltage for Data	$V_{THLDATA-}$	DnP/N Note 5	-70	-	-	mV
Differential Input High Level Threshold Voltage for Clock	$V_{THHCLK+}$	CLKP/N	-	-	70	mV
Differential Input High Level Threshold Voltage for Data	$V_{THHDATA+}$	DnP/N Note 5	-	-	70	mV
Single-ended Input Low Voltage	V_{ILHS}	CLKP/N, DnP/N Note 3, Note 5	-40	-	-	mV
Single-ended Input High Voltage	V_{IHHS}	CLKP/N, DnP/N Note 3, Note 5	-	-	460	mV
Differential Termination Resistor	R_{TERM}	CLKP/N, DnP/N Note 5	80	100	125	Ω
Single-ended Threshold Voltage for Termination Enable	$V_{TERM-EN}$	CLKP/N, DnP/N Note 5	-	-	450	mV
Termination Capacitor	C_{TERM}	CLKP/N, DnP/N Note 5, Note 6	-	-	60	pF

Notes:

1. $T_a = -30^{\circ}C$ to $70^{\circ}C$ (to $+85^{\circ}C$ no damage), $V_{CI} = 2.5V$ to $6.6V$, $V_{DDI} = 1.65V$ to $3.6V$
2. Includes $50mV$ ($-50mV$ to $50mV$) ground difference
3. Without $V_{CMRCLKM450}/V_{CMRDATAM450}$
4. Without $50mV$ ($-50mV$ to $50mV$) ground difference
5. $n = 0, 1, 2$ and 3
6. For higher bit rates, a $14pF$ capacitor will be needed to meet the common-mode return loss specification.

The DSI receiver (HS mode) understands that there is logical 1 (= HS-1) when a differential voltage is more than V_{THH} (CLKP/DnP). The DSI receiver (HS mode) understands that there is logical 0 (= HS-0) when a differential voltage is more than V_{THL} (CLKN/DnN). There is undefined state if the differential voltage is less than V_{THH} (CLKP/DnP) and less than V_{THL} (CLKN/DnN). A reference figure is below.

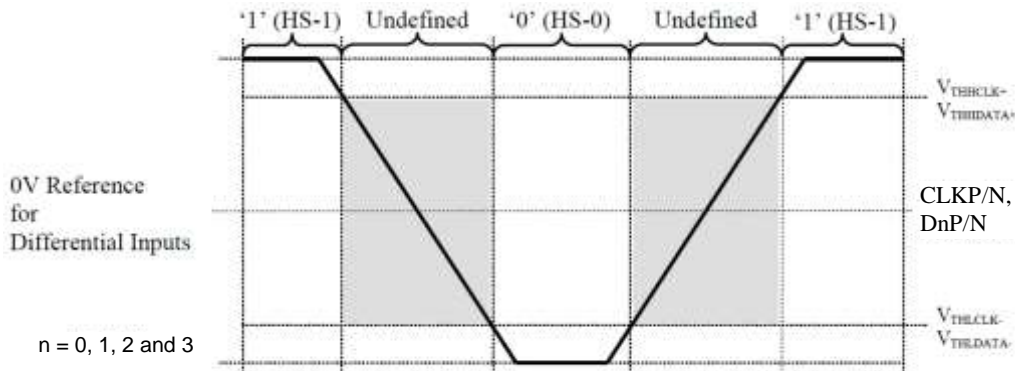
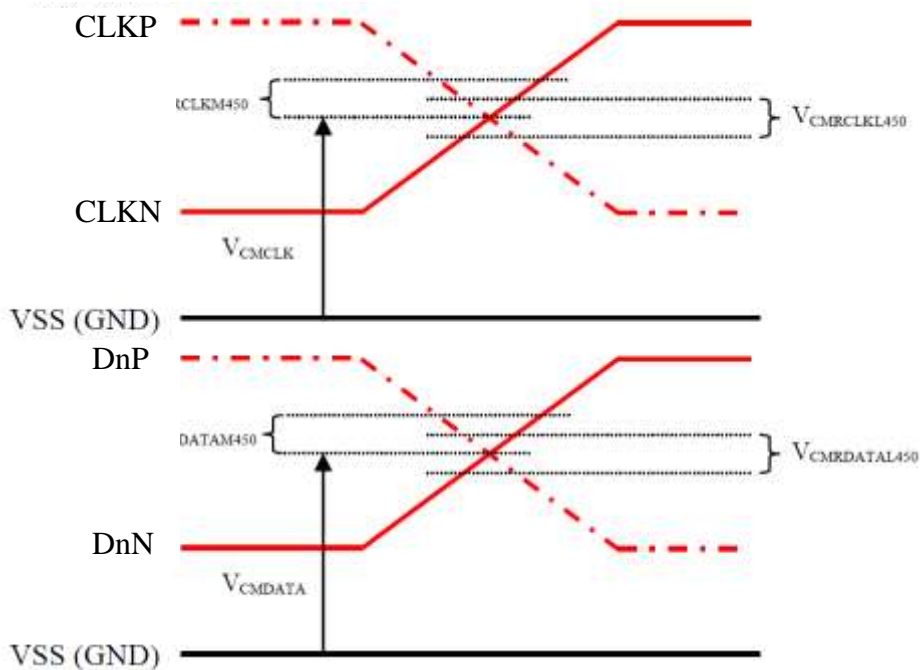

Figure 113: Differential Inputs Logical 0 and 1, Threshold High/Low, Differential Voltage Range



Note: $n = 0, 1, 2$ and 3

Figure 114: Common Mode Voltage on Clock and Data Channels

The termination resistor (R_{TERM}) of the differential DSI receiver can be driven to two different states by the receiver:

- ❖ Low Power (LP) mode when the termination resistor is not connected between differential inputs (CLKP \Leftrightarrow CLKN or D0P \Leftrightarrow D0N or D1P \Leftrightarrow D2N or D2P \Leftrightarrow D3N or D1P \Leftrightarrow D3N)
- ❖ High Speed (HS) mode when the termination resistor is connected between differential inputs (CLKP \Leftrightarrow CLKN or D0P \Leftrightarrow D0N or D1P \Leftrightarrow D2N or D2P \Leftrightarrow D3N or D1P \Leftrightarrow D3N)

The termination switch (HS/LP), when the termination resistor is not connected, is illustrated below.

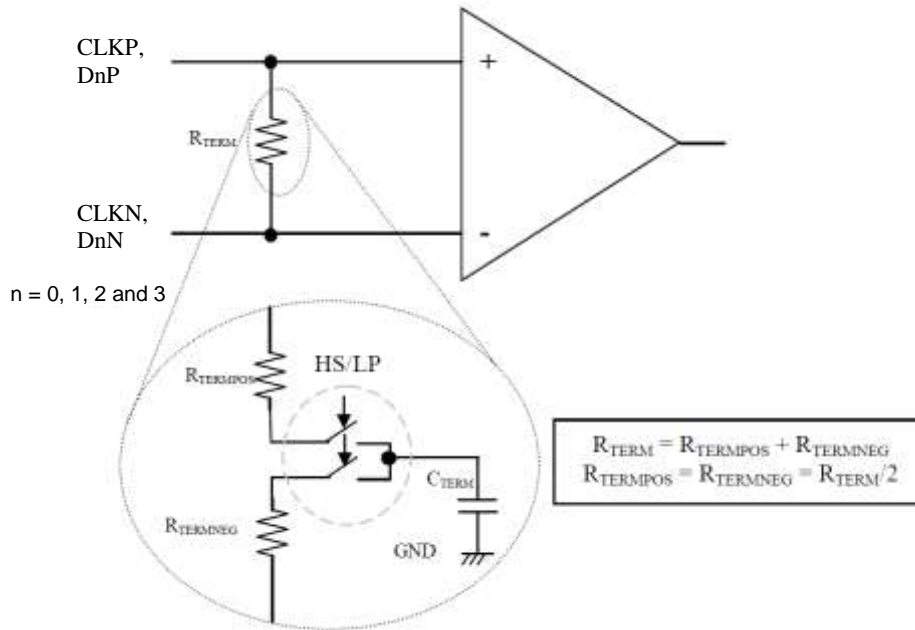

Figure 115: Differential Pair Termination Resistor on the Receiver Side

18.4. AC Characteristics

18.4.1. DSI Timing Characteristics

18.4.2. High Speed Mode – Clock Channel Timing

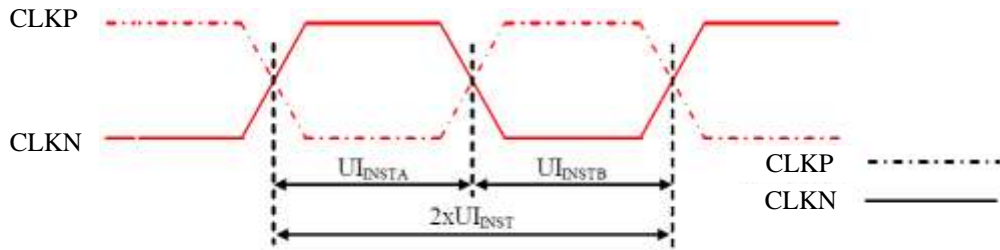

Figure 116: DSI Clock Channel Timing

Table 38: DSI Clock Channel Timing

Signal	Symbol	Parameter	Min	Max	Unit
CLKP/N	$2xUI_{INST}$	Double UI instantaneous	Note 2	25	ns
CLKP/N	UI_{INSTA}, UI_{INSTB} (Note 1)	UI instantaneous Half	Note 2	12.5	ns

Notes:

1. $UI = UI_{INSTA} = UI_{INSTB}$
2. Define the minimum value, see Table 39.

Table 39: Limited Clock Channel Speed

Data type	Two Lanes speed	Three Lanes speed	Four Lanes speed
Data Type = 00 1110 (0Eh), RGB 565, 16 UI per Pixel	566 Mbps	466 Mbps	366 Mbps
Data Type = 01 1110 (1Eh), RGB 666, 18 UI per Pixel	637 Mbps	525 Mbps	412 Mbps
Data Type = 10 1110 (2Eh), RGB 666 Loosely, 24 UI per Pixel	850 Mbps	700 Mbps	550 Mbps
Data Type = 11 1110 (3Eh), RGB 888, 24 UI per Pixel	850 Mbps	700 Mbps	550 Mbps

18.4.3. High Speed Mode – Data Clock Channel Timing

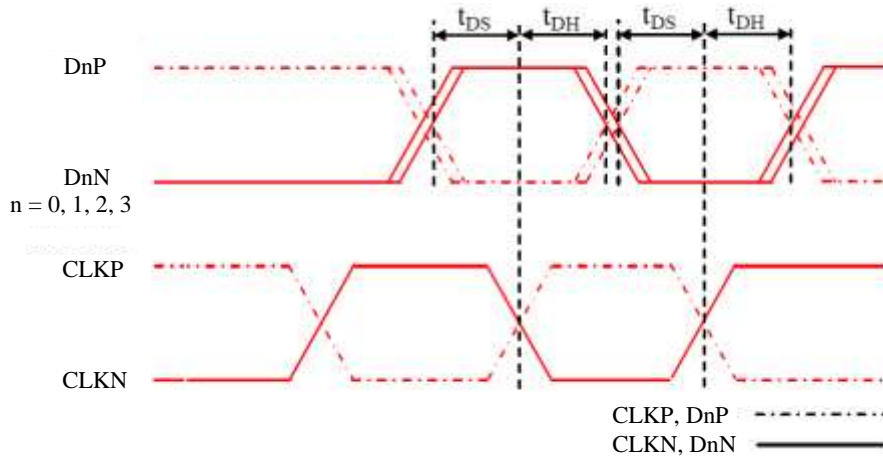

Figure 117: DSI Data to Clock Channel Timings

Table 40: DSI Data to Clock Channel Timings

Signal	Symbol	Parameter	Min	Max
DnP/N , n=0,1,2,3	t_{DS}	Data to Clock Setup time	0.15xUI	-
	t_{DH}	Clock to Data Hold Time	0.15xUI	-

18.4.4. High Speed Mode – Rising and Falling Timings

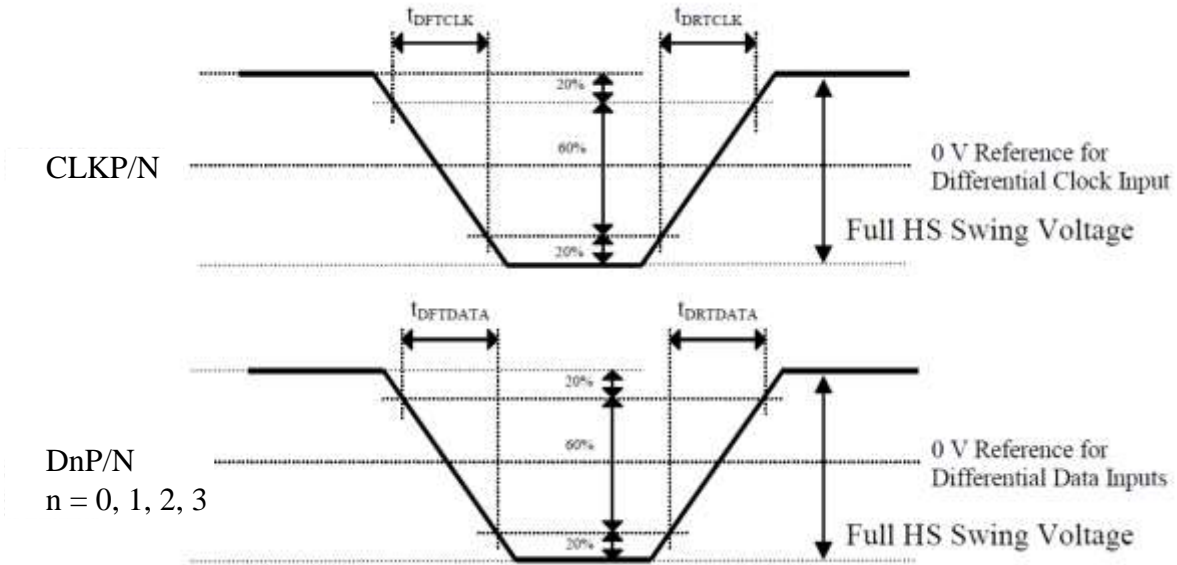

Figure 118: Rising and Falling Timings on Clock and Data Channels

Table 41: Rise and Fall Timings on Clock and Data Channels

Parameter	Symbol	Condition	Specification		
			Min	Typ	Max
Differential Rise Time for Clock	t_{DRTCLK}	CLKP/N	150 ps	-	0.3UI (Note)
Differential Rise Time for Data	$t_{DRTDATA}$	DnP/N n=0,1,2,3	150 ps	-	0.3UI (Note)
Differential Fall Time for Clock	t_{DFTCLK}	CLKP/N	150 ps	-	0.3UI (Note)
Differential Fall Time for Data	$t_{DFTDATA}$	DnP/N n=0,1,2,3	150 ps	-	0.3UI (Note)

Note: The display module has to meet timing requirements, which are defined for the transmitter (MCU) on MIPI D-Phy standard.

18.4.5. Low Speed Mode – Bus Turn Around

Lower Power Mode and its State Periods on the Bus Turnaround (BTA) from the MCU to the Display Module (ILI9881C-0D) are illustrated for reference purposes below.

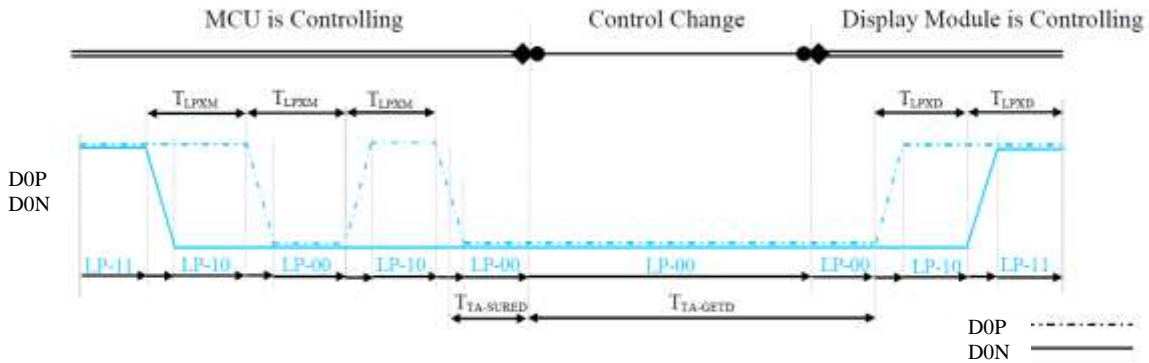

Figure 119: BTA from the MCU to the Display Module

Lower Power Mode and its State Periods on the Bus Turnaround (BTA) from the Display Module (ILI9881C-0D) to the MCU are illustrated for reference purposes below.

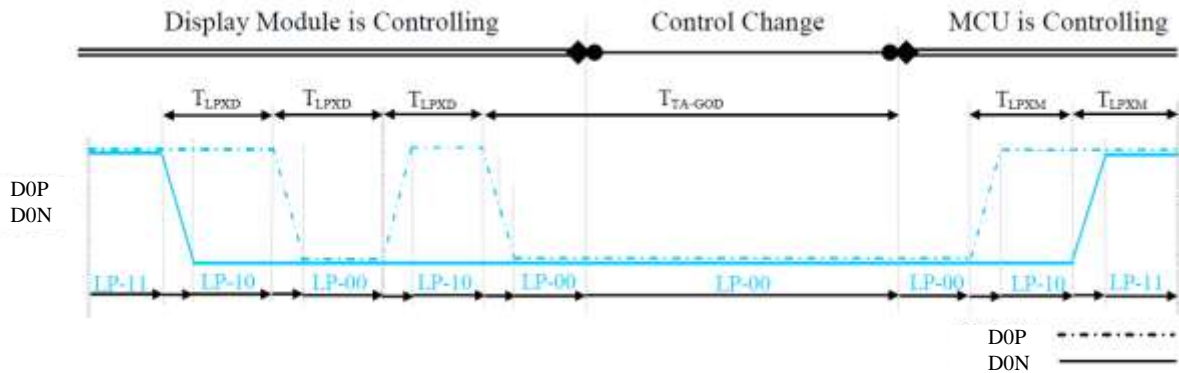

Figure 120: BTA from the Display Module to the MCU

Table 42: Low Power State Period Timings – A

Signal	Symbol	Description	Min	Max	Unit
D0P/N	T_{LPXM}	Length of LP-00, LP-01, LP-10 or LP-11 periods MCU → Display Module (ILI9881C-0D)	50	75	ns
D0P/N	T_{LPXD}	Length of LP-00, LP-01, LP-10 or LP-11 periods Display Module (ILI9881C-0D) → MCU	50	75	ns
D0P/N	$T_{TA-SURED}$	Time-out before the Display Module (ILI9881C-0D) starts driving	T_{LPXD}	$2 \times T_{LPXD}$	ns

Table 43: Low Power State Period Timings – B

Signal	Symbol	Description	Time	Unit
D0P/N	$T_{TA-GETD}$	Time to drive LP-00 by Display Module (ILI9881C-0D)	$5 \times T_{LPXD}$	ns
D0P/N	T_{TA-GOD}	Time to drive LP-00 after turnaround request - MCU	$4 \times T_{LPXD}$	ns

18.4.6. Data Lanes from Low Power Mode to High Speed Mode

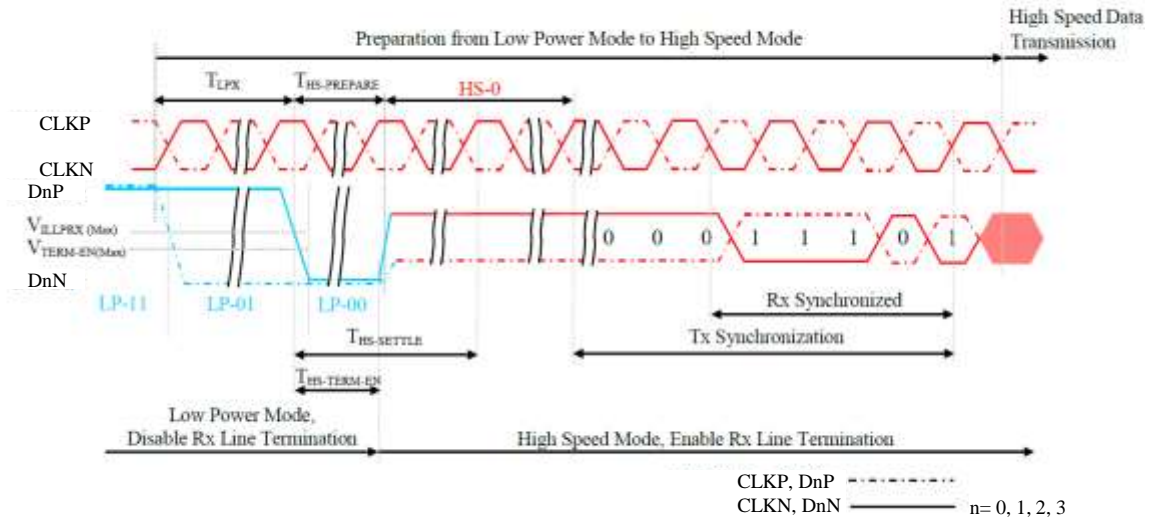

Figure 121: Data Lanes - Low Power Mode to High Speed Mode Timings

Table 44: Data Lanes - Low Power Mode to High Speed Mode Timings

Signal	Symbol	Description	Min	Max	Unit
DnP/N, n = 0,1,2,3	T_{LPX}	Length of any Low Power State Period	50	-	ns
DnP/N, n = 0,1,2,3	$T_{HS-PREPARE}$	Time to drive LP-00 to prepare for HS Transmission	$40+4xUI$	$85+6xUI$	ns
DnP/N, n = 0,1,2,3	$T_{HS-TERM-EN}$	Time to enable Data Lane Receiver line termination measured from when Dn crosses VILMAX	-	$35+4xUI$	ns

18.4.7. Data Lanes from High Speed Mode to Low Power Mode

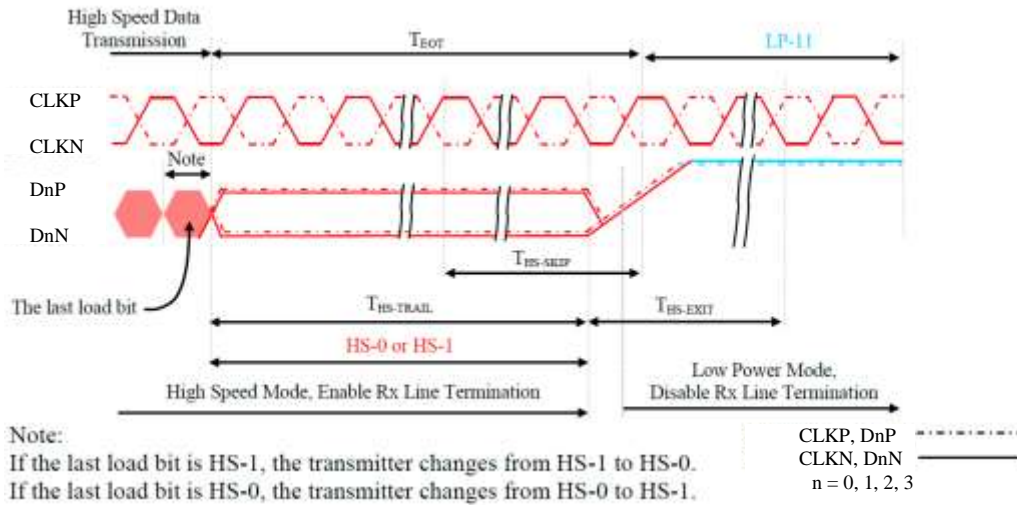

Figure 122: Data Lanes - High Speed Mode to Low Power Mode Timings

Table 45: Data Lanes - High Speed Mode to Low Power Mode Timings

Signal	Symbol	Description	Min	Max	Unit
DnP/N, n = 0,1,2,3	T _{HS-SKIP}	Time-Out at Display Module (ILI9881C-0D) to ignore transition period of EoT	40	55+4xUI	ns
DnP/N, n = 0,1,2,3	T _{HS-EXIT}	Time to driver LP-11 after HS burst	100	-	ns
DnP/N, n = 0,1,2,3	T _{HS-TRAIL}	Time that the transmitter drives the flipped differential state after last payload data bit of a HS transmission burst.	Max(8*UI, 60ns+4*UI)	-	ns

18.4.8. DSI Clock Burst – High Speed Mode to/from Low Power Mode

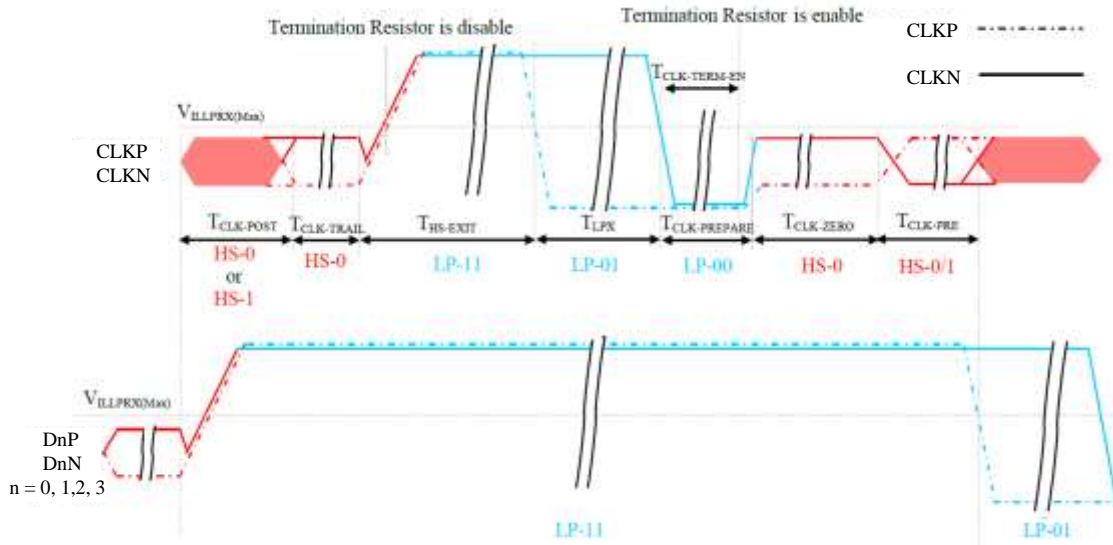
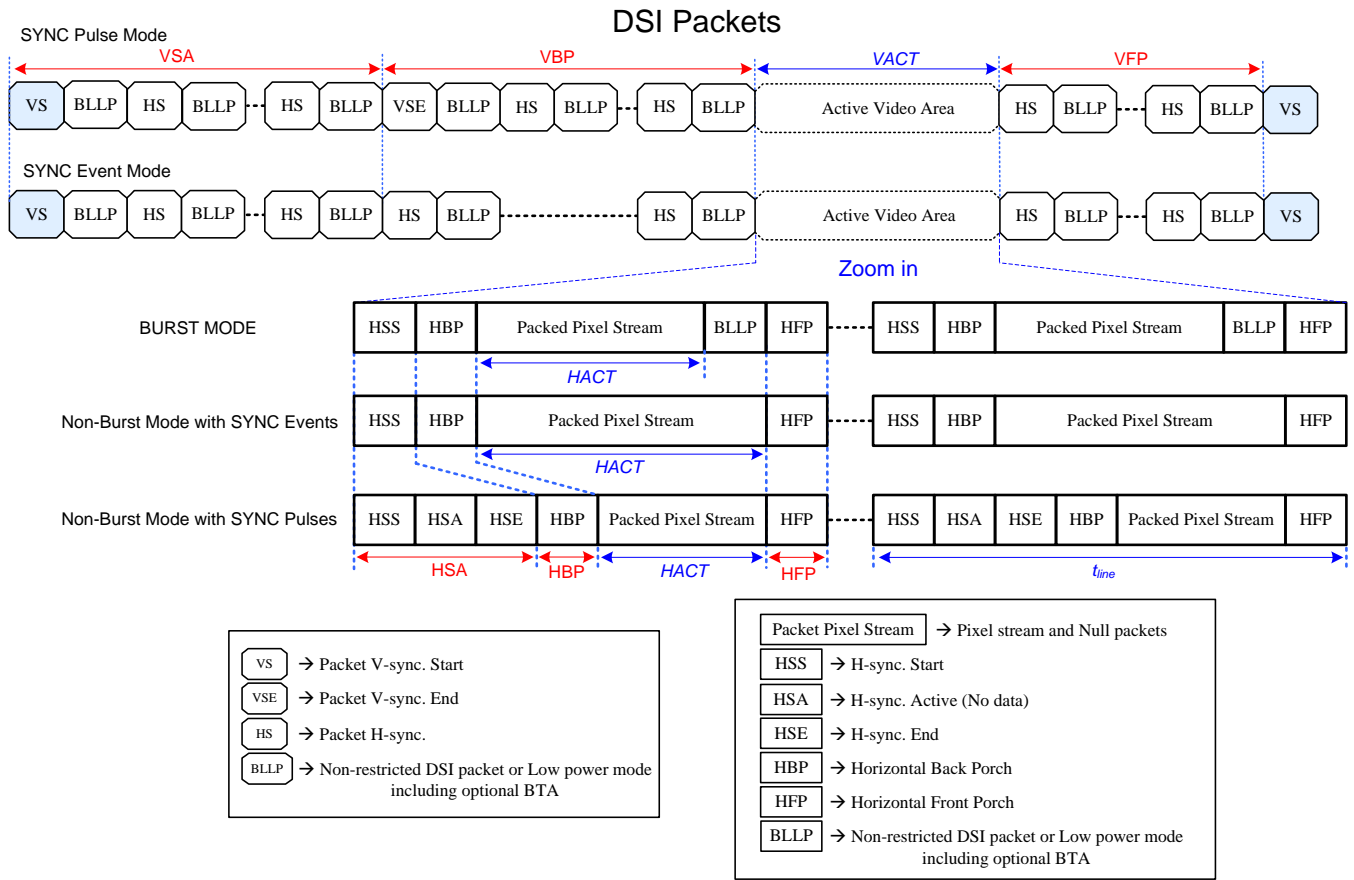

Figure 123: Clock Lanes - High Speed Mode to/from Low Power Mode Timings

Table 46: Clock Lanes - High Speed Mode to/from Low Power Mode Timings

Signal	Symbol	Description	Min	Max	Unit
CLKP/N	T _{CLK-POST}	Time that the MCU shall continue sending HS clock after the last associated Data Lanes has transitioned to LP mode	60+52xUI	-	ns
CLKP/N	T _{CLK-TRAIL}	Time to drive HS differential state after last payload clock bit of a HS transmission burst	60	-	ns
CLKP/N	T _{HS-EXIT}	Time to drive LP-11 after HS burst	100	-	ns
CLKP/N	T _{CLK-PREPARE}	Time to drive LP-00 to prepare for HS transmission	38	95	ns
CLKP/N	T _{CLK-TERM-EN}	Time-out at Clock Lane to enable HS termination	-	38	ns
CLKP/N	T _{CLK-PREPARE} + T _{CLK-ZERO}	Minimum lead HS-0 drive period before starting Clock	300	-	ns
CLKP/N	T _{CLK-PRE}	Time that the HS clock shall be driven prior to any associated Data Lane beginning the transition from LP to HS mode	8xUI	-	ns

18.4.9. Timing for DSI video mode



Parameters	Symbols	Min.	Typ.	Max.	Units
Vertical sync. active	VSA	2 (Note 6)	-	-	Line
Vertical Back Porch	VBP	14 (Note 6)	-	-	Line
Vertical Front Porch	VFP	8 (Note 6)	-	-	Line
Active lines per frame	VACT	-	1280	-	Line
Horizontal sync. active	HSA	2	-	-	Pixel
Horizontal Porch period	HSA + HBP + HFP	1.6	-	-	us
Active pixels per line	HACT	-	720	-	Pixel
Bit rate	BR _{bps}	385		Note 5	Mbps/lane

1 UI=1/Bit rate

$$HSA(\text{pixel}) = (tHSA \times \text{lane number}) / (UI \times \text{pixel format})$$

$$HBP(\text{pixel}) = (tHBP \times \text{lane number}) / (UI \times \text{pixel format})$$

$$HFP(\text{pixel}) = (tHFP \times \text{lane number}) / (UI \times \text{pixel format})$$

$$\text{Frame Rate} = \frac{BR_{bps} \times \text{Lane}_{num}}{(VACT+VSA+VBP+VFP) \times (HACT+HSA+HBP+HFP) \times \text{Pixel Format}}$$

Example : BR_{bps} = 457Mbps/lane, 1UI=2.1883ns, Frame rate=60Hz, VACT=1280, VSA=2, VBP=30, VFP=20, HACT=720, HSA=33, HBP=100, HFP=100, Lane_{num}=4(lane), Pixel Format=24(bit).

Note:

1. Lane_{num}: Date lane of MIPI-DSI.
2. Pixel Format: Please reference to “4.1DSI System Interface”.
3. The formula exists slightly error because of the host-transmission way.
4. The best frame rate setting : 2 data lanes : 50~60 Hz / 3 data lanes : 50~70 Hz / 4 data lanes : 50~70 Hz.
5. Please reference to “Table 39: Limited Clock Channel Speed”.
6. The minimum values of this table mean the limitation of IC without considering the panel GIP. The actual values of VSA, VBP and VFP will be changed by different panel GIP setting.

18.4.10. Reset Timing

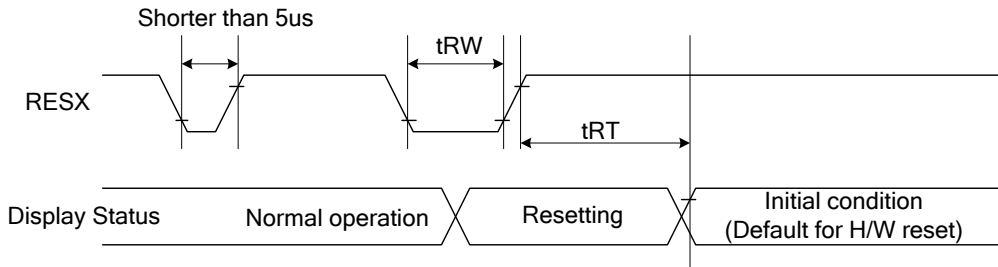

Figure 124: Reset Timing

Table 47: Reset Timing

Signal	Symbol	Parameter	Min	Max	Unit
RESX	tRW	Reset pulse duration	10		µS
	tRT	Reset cancel		5 (note 1,5) 120 (note 1,6,7)	mS

Notes:

1. The reset cancel also includes required time for loading ID bytes, VCOM setting and other settings from EEPROM to registers. This loading is done every time when there is H/W reset cancel time (tRT) within 5 ms after a rising edge of RESX.
2. Spike due to an electrostatic discharge on RESX line does not cause irregular system reset according to the Table 48.

Table 48: Reset Descript

RESX Pulse	Action
Shorter than 5us	Reset Rejected
Longer than 10us	Reset
Between 5us and 10us	Reset starts

3. During the Resetting period, the display will be blanked (The display enters the blanking sequence, which maximum time is 120 ms, when Reset Starts in the Sleep Out mode. The display remains the blank state in the Sleep In mode.) and then return to Default condition for Hardware Reset.
4. Spike Rejection can also be applied during a valid reset pulse, as shown below:

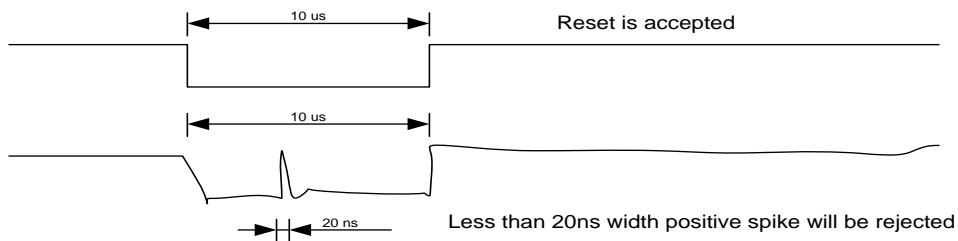

Figure 125: Positive Noise Pulse during Reset Low

5. When Reset applied during Sleep In Mode.
6. When Reset applied during Sleep Out Mode.
7. It is necessary to wait 5msec after releasing RESX before sending commands. Also Sleep Out command cannot be sent for 120msec.

19. Panel Application

19.1. Input Power Type

ILI9881C-0D supports 3 kinds of input power type as shown below.

Table 49: Different Input Power Type

Setting	Input Power Type
<p>Power Mode 2A</p> <p>BOOSTM[2:0] = 1h DI_PWR_REG = 0h</p>	
<p>Power Mode 3</p> <p>BOOSTM[2:0] = 2h DI_PWR_REG = don't care</p>	
<p>Power Mode 4</p> <p>BOOSTM[2:0] = 1h DI_PWR_REG = 1h</p>	

19.2. Power Mode 2A (BOOSTM[2:0] = 1h, DI_PWR_REG = 0h)

19.2.1. Power Structure

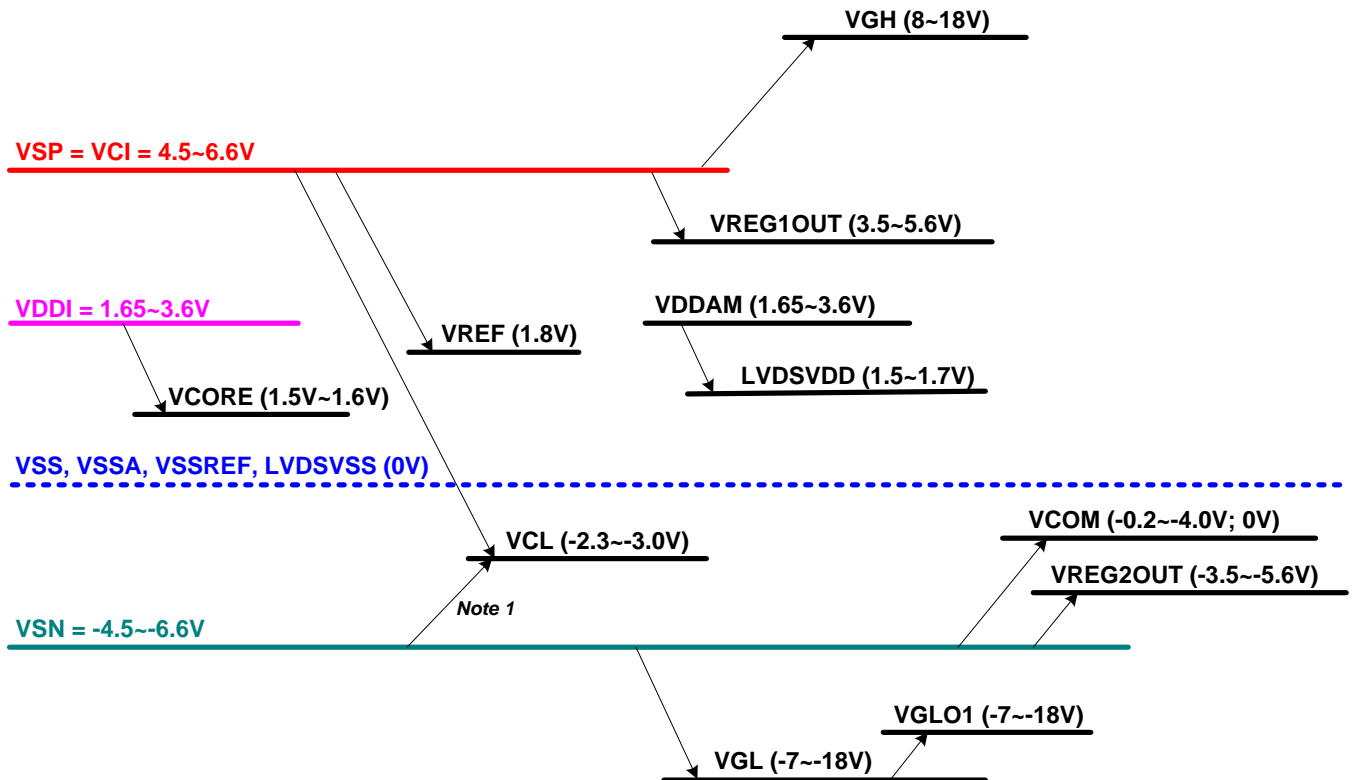

Figure 126: Power Structure of Power Mode 2A

Notes:

1. Please refer to "5.7.12 Power Control 3 (6Fh)".
2. The VREG1OUT, VREG2OUT, VCOM, VGH, VGL and VCL output voltage levels are lower than their theoretical levels (Ideal voltage levels) due to the current consumption at respective outputs.

19.2.3. External Component

Table 50: External Component table of Power Mode 2A

N0.	Pad Name	Typical Value	Note	Reference Command (page)
1	VDDI	1.0uF / 6.3V	I/O and Digital Power	
2	VSP	2.2~4.7uF / 10V	Analog Power	
3	VSN	4.7uF / 10V	Analog Power	
4	VCORE	2.2uF / 6.3V		
5	VCL	1.0uF / 6.3V		
6	VREG1OUT	1.0uF / 10V	Optional	Register Page 4_R7Ah (page.231)
7	VREG2OUT	1.0uF / 10V	Optional	Register Page 4_R7Ah (page.231)
8	VCOM	2.2uF / 6.3V		
9	VGH	1.0uF / 25V		
10	VGL	1.0uF / 25V		
11	VGLO1	1.0uF / 25V	Optional (if not used)	Register Page 4_R6Fh (page.229)
12	C21P/C21N	1.0uF / 16V		
13	C22P/C22N	1.0uF / 25V	Optional	Register Page 4_R6Fh (page.229)
14	C23P/C23N	1.0uF / 16V		
15	C24P/C24N	1.0uF / 25V	Optional	Register Page 4_R6Fh (page.229)
16	C41P/C41N	1.0uF / 6.3V	Optional	Register Page 4_R6Fh (page.229)
17	C42P/C42N	1.0uF / 6.3V	Optional	Register Page 4_R6Fh (page.229)

19.3. Power Mode 3 (BOOSTM[2:0] = 2h, DI_PWR_REG = don't care)

19.3.1. Power Structure

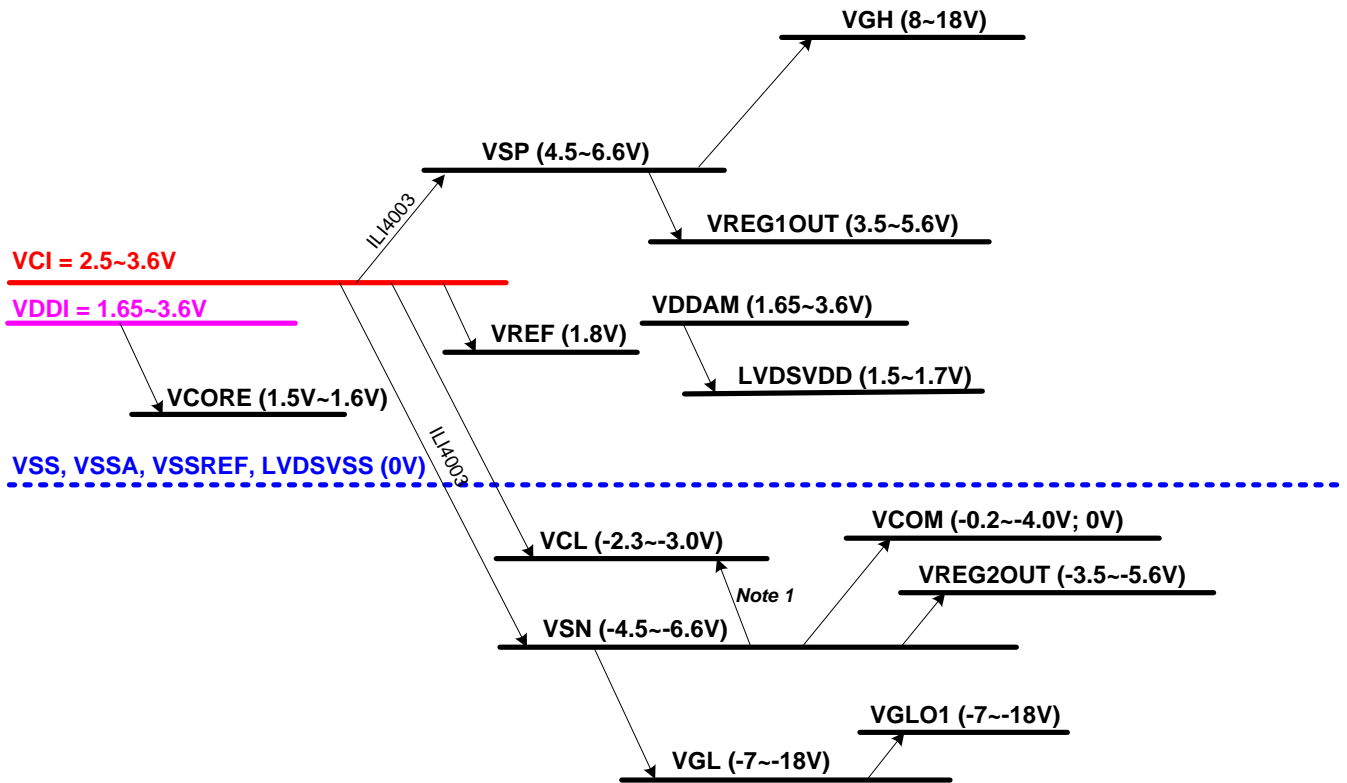

Figure 128: Power Structure of Power Mode 3

Notes:

1. Please refer to "5.7.12 Power Control 3 (6Fh)".
2. The VSP, VSN, VREG1OUT, VREG2OUT, VCOM, VGH, VGL and VCL output voltage levels are lower than their theoretical levels (Ideal voltage levels) due to the current consumption at respective outputs.

19.3.3. External Component

Table 51: External Component table of Power Mode 3

N0.	Pad Name	Typical Value	Note	Reference Command (page)
1	VCI	1.0uF / 6.3V	Analog Power	
2	VDDI	1.0uF / 6.3V	I/O and Digital Power	
3	VSP	2.2~4.7uF / 10V		
4	VSN	2.2~4.7uF / 10V		
5	VCORE	2.2uF / 6.3V		
6	VCL	1.0uF / 6.3V		
7	VREG1OUT	1.0uF / 10V	Optional	Register Page 4_R7Ah (page.231)
8	VREG2OUT	1.0uF / 10V	Optional	Register Page 4_R7Ah (page.231)
9	VCOM	2.2uF / 6.3V		
10	VGH	1.0uF / 25V		
11	VGL	1.0uF / 25V		
12	VGLO1	1.0uF / 25V	Optional (if not used)	Register Page 4_R6Fh (page.229)
13	C21P/C21N	1.0uF / 16V		
14	C22P/C22N	1.0uF / 25V	Optional	Register Page 4_R6Fh (page.229)
15	C23P/C23N	1.0uF / 16V		
16	C24P/C24N	1.0uF / 25V	Optional	Register Page 4_R6Fh (page.229)
17	C41P/C41N	1.0uF / 6.3V	Optional	Register Page 4_R6Fh (page.229)
18	C42P/C42N	1.0uF / 6.3V	Optional	Register Page 4_R6Fh (page.229)
19	Q1		ILI4003	
20	C1P/C1N	2.2uF / 6.3V		
21	C2P/C2N	2.2uF / 6.3V		
22	C3P/C3N	2.2uF / 6.3V		

19.4. Power Mode 4 (BOOSTM[2:0] = 1h, DI_PWR_REG = 1h)

19.4.1. Power Structure

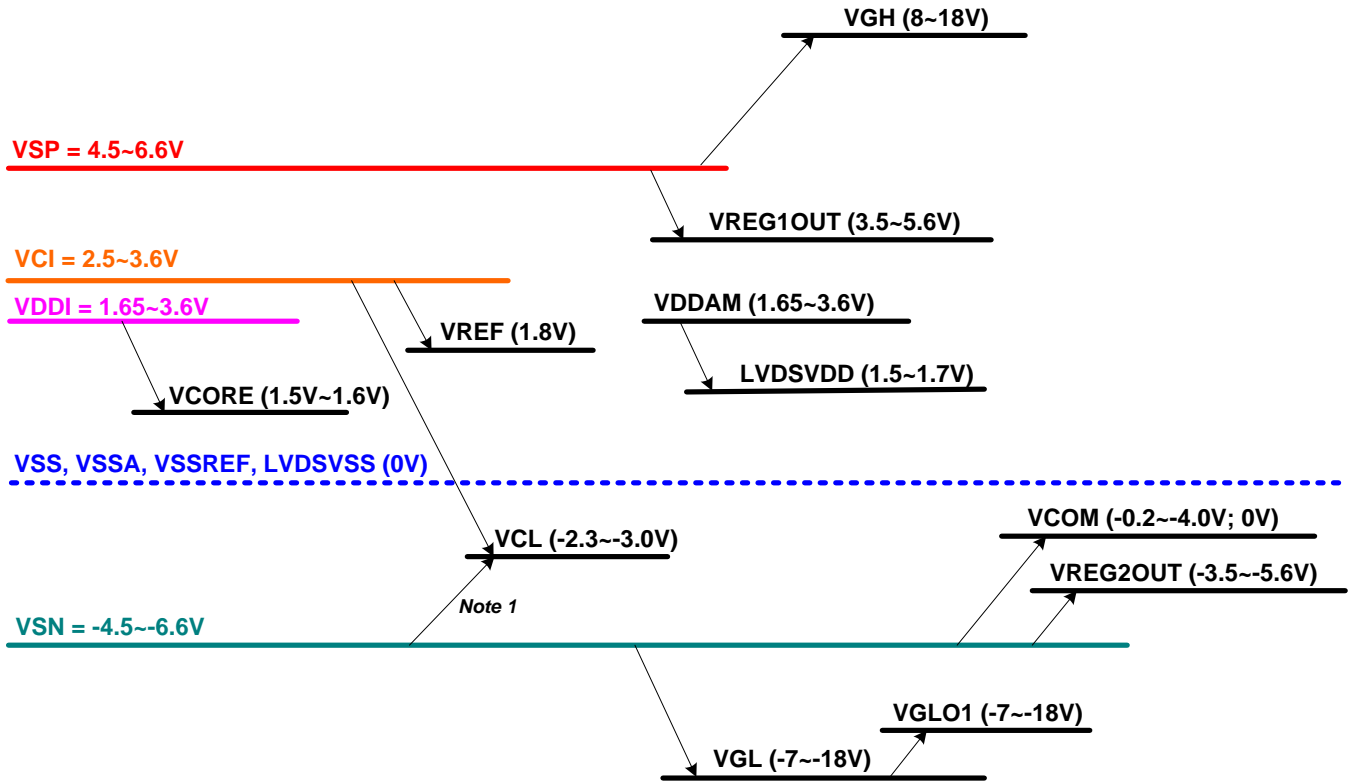

Figure 130: Power Structure of Power Mode 4

Notes:

1. Please refer to "5.7.12 Power Control 3 (6Fh)".
2. The VREG1OUT, VREG2OUT, VCOM, VGH, VGL and VCL output voltage levels are lower than their theoretical levels (Ideal voltage levels) due to the current consumption at respective outputs.

19.4.2. Reference Circuit

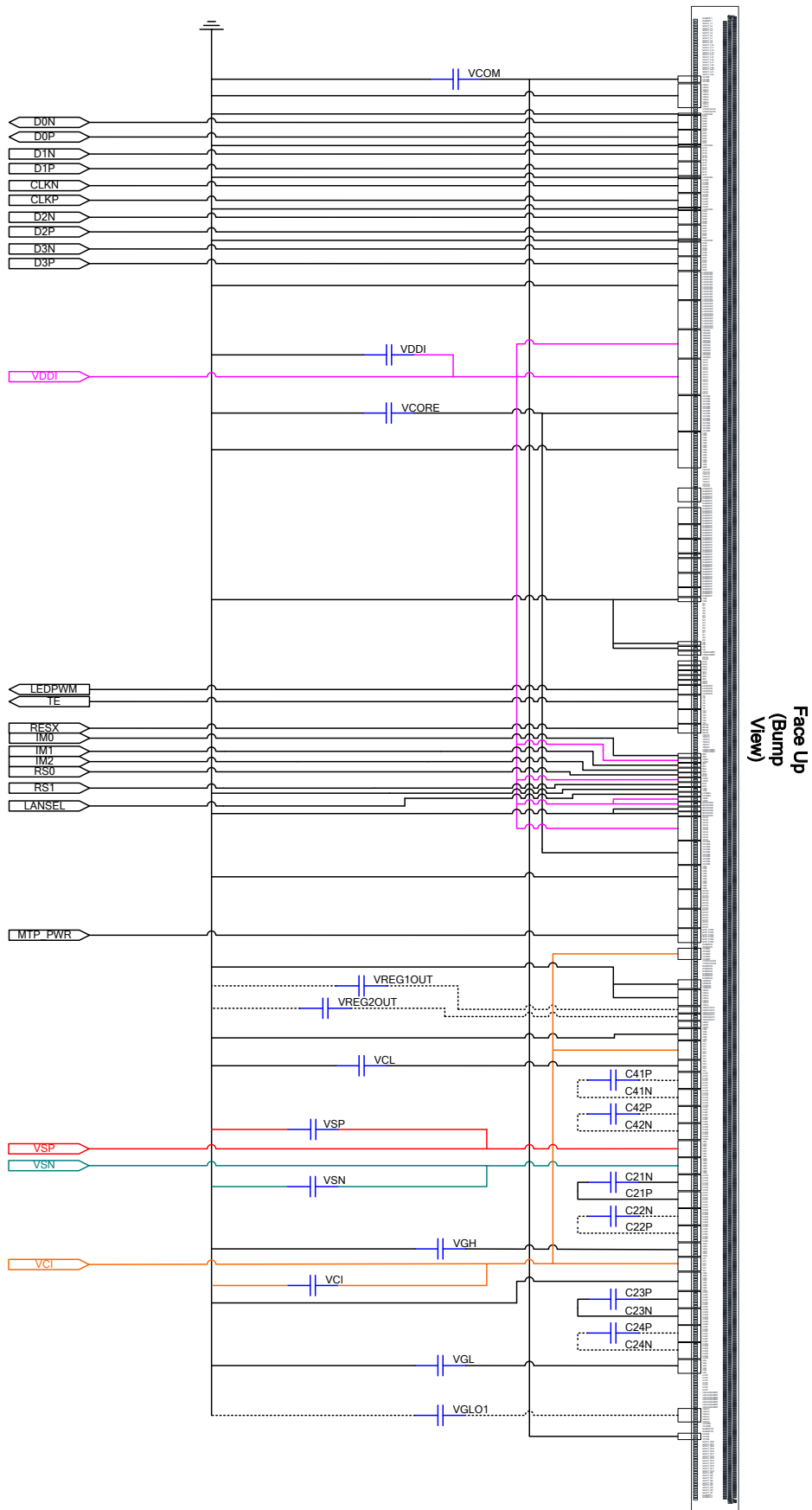

Figure 131: Reference Circuit of Power Mode 4

19.4.3. External Component

Table 52: External Component table of Power Mode 4

N0.	Pad Name	Typical Value	Note	Reference Command (page)
1	VDDI	1.0uF / 6.3V	I/O and Digital Power	
2	VCI	1.0uF / 6.3V	Analog Power	
3	VSP	2.2~4.7uF / 10V	Analog Power	
4	VSN	4.7uF / 10V	Analog Power	
5	VCORE	2.2uF / 6.3V		
6	VCL	1.0uF / 6.3V		
7	VREG1OUT	1.0uF / 10V	Optional	Register Page 4_R7Ah (page.231)
8	VREG2OUT	1.0uF / 10V	Optional	Register Page 4_R7Ah (page.231)
9	VCOM	2.2uF / 6.3V		
10	VGH	1.0uF / 25V		
11	VGL	1.0uF / 25V		
12	VGLO1	1.0uF / 25V	Optional (if not used)	Register Page 4_R6Fh (page.229)
13	C21P/C21N	1.0uF / 16V		
14	C22P/C22N	1.0uF / 25V	Optional	Register Page 4_R6Fh (page.229)
15	C23P/C23N	1.0uF / 16V		
16	C24P/C24N	1.0uF / 25V	Optional	Register Page 4_R6Fh (page.229)
17	C41P/C41N	1.0uF / 6.3V	Optional	Register Page 4_R6Fh (page.229)
18	C42P/C42N	1.0uF / 6.3V	Optional	Register Page 4_R6Fh (page.229)

19.5. Maximum Layout Resistance

Table 53: Maximum Layout Resistance

Pad Name	Type	Maximum series resistance	Unit
VCI	Power Supply	5	Ω
VCIREF	Power Supply	10	Ω
VDDI	Power Supply	5	Ω
VCC1	Power Supply	5	Ω
VCC2	Power Supply	5	Ω
VDDAM	Power Supply	5	Ω
VSP	Power Supply	5	Ω
VSN	Power Supply	5	Ω
VSSA	Ground	5	Ω
VSSREF	Ground	10	Ω
LVDSVSS	Ground	50	Ω
VSS	Ground	5	Ω
MTP_PWR	Power Supply	5	Ω
VREG1OUT	Analog	20	Ω
VERG2OUT	Analog	20	Ω
VCL	Analog	5	Ω
VGH	Analog	10	Ω
VGL	Analog	10	Ω
VGLO1	Analog	10	Ω
EXTP	Output	10	Ω
EXTN	Output	10	Ω
LVDSVDD	Analog	5	Ω
VREF	Analog	20	Ω
VCORE	Analog	5	Ω
C21P, C21N, C22P, C22N C23P, C23N, C24P, C24N C41P, C41N, C42P, C42N	Step-up Capacitor	5	Ω
IM[2:0], RS[1:0] LANSEL, BOOSTM[2:0]	Input	100	Ω
RESX	Input	100	Ω
TE, TE1, LEDPWM	Output	50	Ω
CLKP, CLKN D1P, D1N D2P, D2N D3P, D3N	Input	5	Ω
D0P, D0N	Input + Output	5	Ω
CSX, DCX, SCL, SDI	Input	100	Ω
SDO	Output	100	Ω
GOUT_L[22:1] GOUT_R[22:1]	Output	10	Ω
VCOM	Analog	5	Ω
VTESTOUTP	Analog	100	Ω
VTESTOUTN	Analog	100	Ω
TOUT[3:0]	Input + Output	100	Ω
TEST[5:0]	Input + Output	100	Ω
VS, HS	Input + Output	100	Ω
PCLK	Input	100	Ω
D[7:0]	Input + Output	50	Ω

20. Liquid Crystal Power Supply Specifications

Table 54: Liquid Crystal Power Supply Specifications

Item		Description
TFT Source Driver		2404 pins , 800(RGB)
TFT Gate Driver Control Signal		44 pins
TFT Display's Capacitor Structure		Cst structure only (Cs on Common)
Liquid Crystal Drive Output	S1 ~ 2400, SDUM[3:0]	V0 ~ V255 grayscales
	GOUT_L/R[22:1]	VGH – VGL
	VCOM	-4.0 ~ -0.2V; 0V
Input Power Voltage	VCI	2.50 ~ 6.6V
	VCIREF	2.50 ~ 6.6V
	VDDI	1.65 ~ 3.6V
	VCC1	1.65 ~ 6.6V
	VCC2	1.65 ~ 6.6V
	VDDAM	1.65 ~ 3.6V
	VSP	4.5 ~ 6.6V
	VSN	-6.6 ~ -4.5V
Liquid Crystal Drive Voltages	VGH	8.0V ~ 18.0V
	VGL	-18.0V ~ -7.0V
	VCL	-3.0V ~ -2.3V
	VGH – VGL	Max. 32.0V
Internal Step-up Circuits	VGH	2xVSP or 2.5xVSP or 3*VSP or 3.5*VSP or 4*VSP or 4.5*VSP or 5*VSP
	VGL	-1.5xVSP or -2xVSP or -2.5xVSP or -3xVSP or -3.5xVSP or -4xVSP or -4.5xVSP or -5xVSP

21. Revision History

Version No.	Date	Page	Description
V098	2015/11/11	All	New created
V099	2016/01/08	181 282	Modify Page1_R02h Modify Rise time
V100	2016/03/15	284	Modify Power on/off sequence
V101	2016/05/13	288	Modify External MTP_PWR Programming Flow
V102	2017/03/16	18 304	Delete 640 (RGB) (H) x (480 + (4 x NL) (V) resolution Modify High Speed Mode to Low Power Mode Timings