



ILITEK
I Love Innovation

ILI2511

ILI2511

Single Chip Capacitive Touch Sensor Controller

Specification

Version: V1.5

Date: 2019/1/17

ILI TECHNOLOGY CORP.

8F., No.1, Taiyuan 2nd St., Zhubei City, Hsinchu County 302, Taiwan (R.O.C.)

Tel.886-3-5600099; Fax.886-3-5600055

<http://www.ilitek.com>

Revision History

Version	Date	Page	Description
V1.01	2016/8/10	All	Preliminary released
V1.02	2016/9/19	6,7,17,18	Modify the pin description & application circuit.
V1.03	2016/10/27	6,7	Modify the pin assignment & pin description.
V1.04	2016/11/3	2	Modify the page information of revision history.
V1.05	2016/11/28	4,17,18	Modify the feature and application circuit.
V1.06	2017/2/9	4.7,10,11	Modify VDDIO operation voltage
V1.07	2017/3/28	14,15	Modify Power Sequence
V1.08	2017/5/18	9,10,11,13	Modify Recommended Operating Conditions, DC Characteristics, I2C DC Characteristics
V1.1	2017/9/7	All	Final Specification released
V1.2	2017/10/13	All	Change VDDIO From 5V into 3.3V
V1.3	2017/12/20	All	Add VDDIO 3.3V or 1.8V Input Power Supply Characteristics Add Marking Information
V1.4	2018/7/5	10,11	Modify Input Power Supply Voltage Range
V1.5	2019/01/17	7,11	Modify Pin Description and DC Characteristics table

Table of Content

REVISION HISTORY	2
TABLE OF CONTENT	3
1. DESCRIPTION	4
2. FEATURES	4
3. BLOCK DIAGRAM	5
4. PIN DEFINITION	6
4.1 QFN-88 PIN ASSIGNMENT	6
4.2 QFN-88 PIN DESCRIPTION	7
5. ELECTRICAL CHARACTERISTICS	9
5.1 ABSOLUTE MAXIMUM RATINGS.....	9
5.2 RECOMMENDED OPERATING CONDITIONS	10
5.3 DC CHARACTERISTICS.....	11
5.4 I2C AC CHARACTERISTICS	13
6. POWER SEQUENCE	14
6.1 POWER-ON SEQUENCE	14
6.2 POWER-OFF TO POWER-ON SEQUENCE.....	15
7. PACKAGE INFORMATION	16
7.1 QFN-88 PACKAGE DIMENSION	16
7.2 MARKING INFORMATION.....	17
8. TYPICAL APPLICATION CIRCUIT	18
8.1 USB APPLICATION CIRCUIT	18
8.2 I2C APPLICATION CIRCUIT	19

1. Description

The ILI2511 is a single chip capacitive touch sensor controller optimized for POS, ATM and Industry Capacitive Touch Panel applications. It integrates high speed Capacitance to Digital Converter (CDC), total 65 channels including high voltage Driving and Sensing channels, high voltage Charge Pump Controller, high voltage regulator and 32-bit high performance Micro-controller (MCU). With compact QFN-88 package, its package size is 10mm*10mm*1mm and pad pitch is 0.4mm. ILI2511 meets all Windows 8.1 and Windows 10 requirements with best user touch experience and highest noise immunity performance.

2. Features

- 65 channels for capacitive touch panel
- Flexible driving or sensing channel assignment
- Max TX channel number is 42
- Max RX channel number is 41
- Programmable driving voltage for driving channels
- High voltage charge pump controller with programmable high voltage regulator
- High speed ADC converter
- Support baseline calibration function
- Support mutual-capacitance sensing
- Support self-capacitance sensing
- Built-in noise processing function
- Support IEC 61000-4-6 (CS test), Level 3: 10Vrms
- Built-in 1.8V LDO for 1.8V operation of VDDIO for I2C and GPIO
- Built-in 32-bit high performance Micro-controller (MCU)
- Input voltage low level detection circuit
- Input voltage power on reset circuit
- Driving to Sensing mutual capacitance: 1pF to 4pF

3. Block Diagram

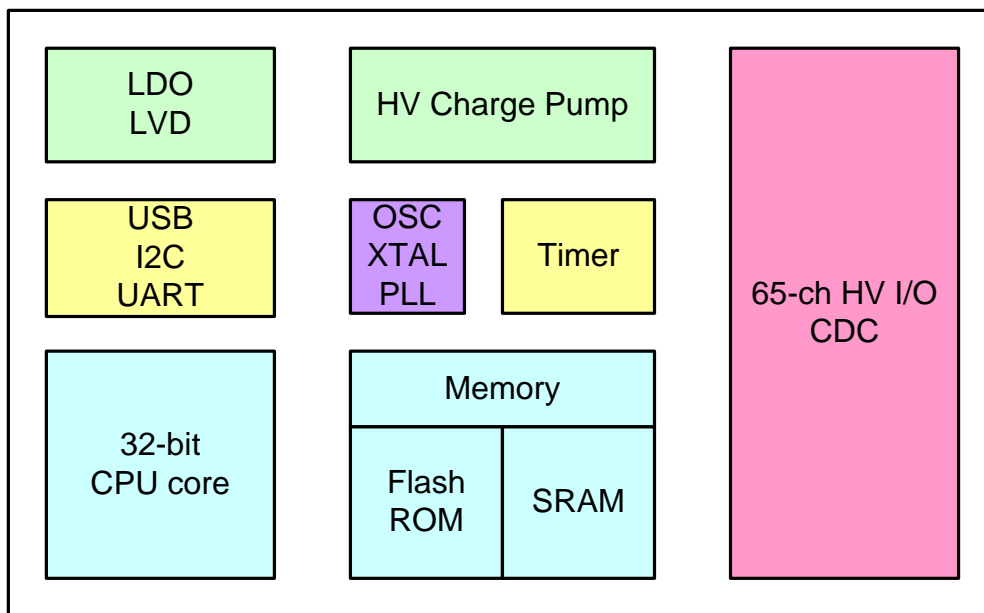

Figure 3-1: ILI2511 Block Diagram

4. Pin Definition

4.1 QFN-88 Pin Assignment

Bottom View

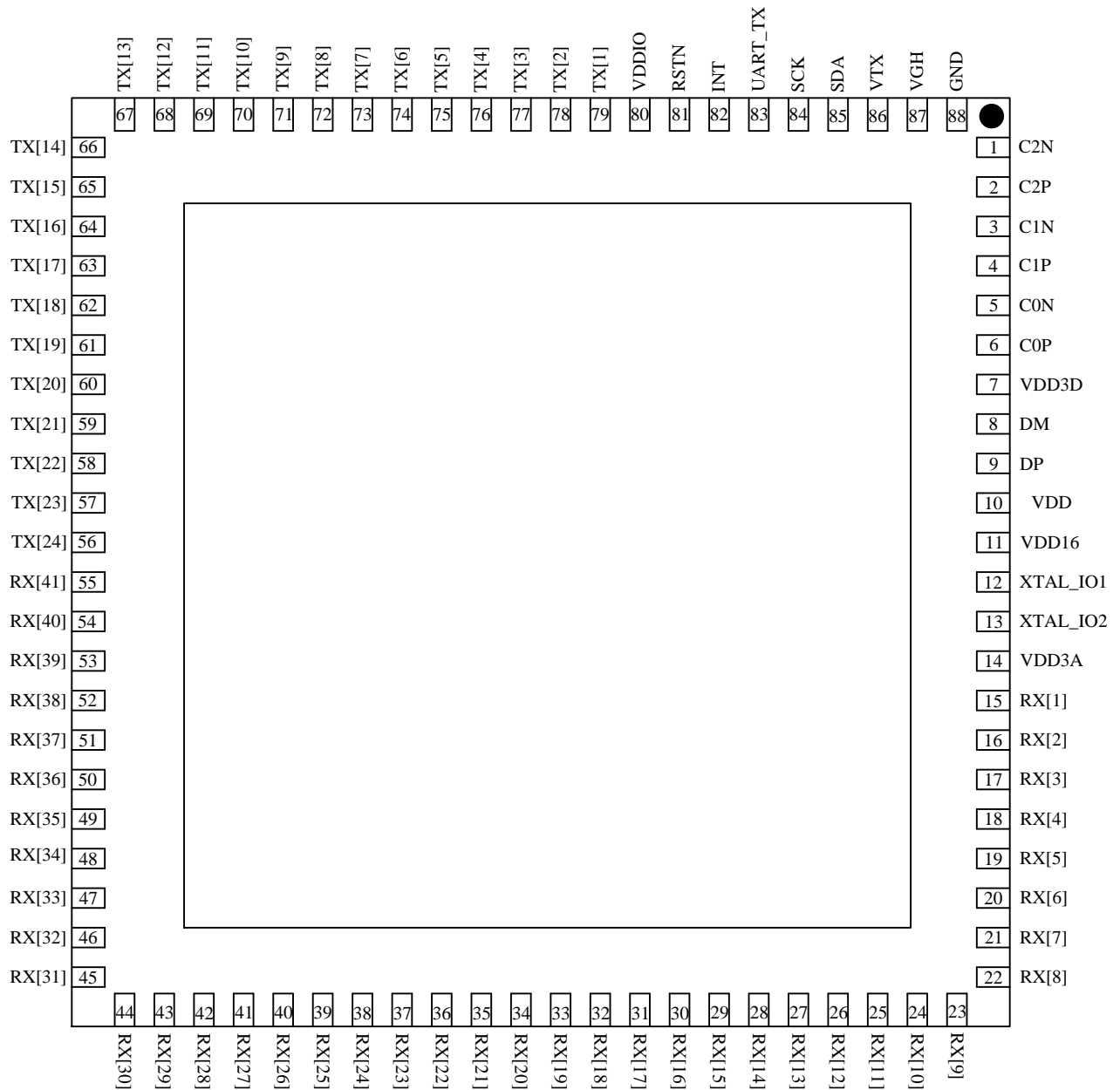

Figure 4-1: ILI2511 QFN-88 Pin Assignment

4.2 QFN-88 Pin Description

Table 4-1 Pin Type Define

Symbol	Description
P	Power pad
CLK	Clock
I	Input only
O	Output only (Push-pull)
I/O	input / output pad

Table 4-2 ILI2511 Pin Description

Name	Type	Description
VDD	P	3.3V input power supply, connect 1uF capacitor to system ground
VDD3D	P	3.3V input power supply, connect 1uF capacitor to system ground
VDD3A	P	3.3V input power supply, connect 1uF capacitor to system ground
VDDIO	P	1.8V or 3.3V input power supply for I2C, SPI, UART, INT, RSTN, connect 2.2uF capacitor to system ground
VDD16	P	1.6V regulator output, connect 1uF capacitor to system ground
VTX	P	HV regulator output, connect 1uF capacitor to system ground
VGH	P	Charge pump HV output, connect 1uF capacitor to system ground
GND	P	connect to system ground
C2N	P	Cathode of charge pump capacitor, connect 1uF capacitor to C2P
C2P	P	Anode of charge pump capacitor, connect 1uF capacitor to C2N
C1N	P	Cathode of charge pump capacitor, connect 1uF capacitor to C1P
C1P	P	Anode of charge pump capacitor, connect 1uF capacitor to C1N
C0N	P	Cathode of charge pump capacitor, connect 1uF capacitor to C0P
C0P	P	Anode of charge pump capacitor, connect 1uF capacitor to C0N
DM	I/O	USB interface, D- signal.
DP	I/O	USB interface, D+ signal.
XTAL_IO1	I/O	External crystal input, connect 12Mhz crystal for USB application
XTAL_IO2	I/O	External crystal output, connect 12Mhz crystal for USB application
RSTN	I/O	External hardware reset input, connect 0.1uF capacitor to ground.
INT	I/O	Interrupt output
UART_TX	I/O	UART TXD output.
I2C_SCL	I/O	I2C interface, clock input.

I2C_SDA	I/O	I2C interface, data input.
RX[1:23]	I/O	Typical touch panel sensing channels
RX[24:41]	I/O	Typical touch panel sensing channels and can be configured to driving channels
TX[1:24]	I/O	Typical touch panel driving channels
EPAD	P	connect to system ground

5. Electrical Characteristics

5.1 Absolute Maximum Ratings

Stresses beyond those listed under “Absolute Maximum Ratings” may cause permanent damage to the device. These are for stress ratings. Functional operation of the device at these or any other conditions beyond those indicated in the operational sections of the specifications is not implied. Exposure to absolute maximum rating conditions for extended periods may remain possibility to affect device reliability.

Table 5-1: Absolute Maximum Ratings

Parameter	Symbol	Min	Max	Unit
Chip power input	V_{DD}	-0.3	3.6	V
V_{DD3A} to GND	V_{DD3A}	-0.3	3.6	V
V_{DD3D} to GND	V_{DD3D}	-0.3	3.6	V
V_{DDIO} to GND	V_{DDIO}	-0.3	3.6	V
V_{DD16} to GND	V_{DD16}	-0.3	1.65	V
V_{GH} to GND	V_{GH}	-0.3	32	V
V_{TX} to GND	V_{TX}	-0.3	32	V
ESD Susceptibility HBM (Human Body Mode)(Note 1)	HBM		4000	V
ESD Susceptibility MM (Machine Mode) (Note 1)	MM		400	V
Operating Ambient Temperature Range	T_A	-40	85	°C
Operating Junction Temperature Range	T_J	-40	125	°C
Storage Ambient Temperature Range	T_{ST}	-40	150	°C

Note 1: Devices are ESD sensitive. Handling precaution is recommended.

5.2 Recommended Operating Conditions

Table 5-2: Recommended Operating Conditions

Parameter	Symbol	Min	Max	Unit
V _{DD} to GND input power supply voltage	V _{DD}	3.0	3.6	V
V _{DD3A} to GND	V _{DD3A}	3.0	3.6	V
V _{DD3D} to GND	V _{DD3D}	3.0	3.6	V
V _{DDIO} (3.3V) to GND	V _{DDIO}	3.0	3.6	V
V _{DDIO} (1.8V) to GND	V _{DDIO}	1.7	1.9	V
V _{DD16} to GND	V _{DD16}	1.55	1.65	V
V _{GH} to GND	V _{GH}	23	32	V
V _{TX} to GND	V _{TX}	19	21	V
Operating Ambient Temperature Range	T _A	-40	85	°C
Operating Junction Temperature Range	T _J	-40	125	°C
Storage Ambient Temperature Range	T _{ST}	-40	150	°C

Note: The device is not guaranteed to function outside its operating conditions.

5.3 DC Characteristics

Table 5-3: Input Power Supply

(VDD3A=VDD3D=3.3V, Room Temperature)

Item	Symbol	Min	Typ.	Max	Unit	Condition
Digital input power supply voltage*	V _{DD3D}	3.0	3.3	3.6	V	
Analog input power supply voltage	V _{DD3A}	3.0	3.3	3.6	V	
3.3V I/O input power supply voltage*	V _{DDIO}	3.0	3.3	3.6	V	
1.8V I/O input power supply voltage*	V _{DDIO}	1.7	1.8	1.9	V	

*If VDDIO & VDD3D is not supplied power, there is risk of I/O pin with current leakage

Table 5-4: DC Characteristics

(VDD3A=VDD3D=3.3V, Room Temperature)

Item	Symbol	Min	Typ.	Max	Unit	Condition
Operation current	I _{op}		100		mA	Active Mode @ 21.5"
Input Low Voltage	V _{IL1}	0		0.3V _{DDIO}	V	
Input High Voltage	V _{IH1}	0.6V _{DDIO}			V	
Hysteresis voltage	V _{HY}		0.2V _{DDIO}		V	
Input Low Voltage, XT_In	V _{IL2}	0		0.6	V	V _{DDIO} =3.3V
Input High Voltage, XT_In	V _{IH2}	2.6			V	V _{DDIO} =3.3V
Negative going threshold, /Reset	V _{ILS}	0		0.2V _{DDIO}	V	
Positive going threshold, /Reset	V _{IHS}	0.6V _{DDIO}			V	
Output High Voltage	V _{OH}	0.7V _{DDIO}			V	V _{DDIO} =3.3V, I _{OH} =8mA
Output Low Voltage	V _{OL}			0.3V _{DDIO}	V	V _{DDIO} =3.3V, I _{OL} =10mA

Table 5-5: USB DC Characteristics

Item	Symbol	Min	Typ.	Max	Unit	Condition
Input Low	V_{IL}			0.8	V	
Input High (driven)	V_{IH}	2.0			V	
Differential input sensitivity	V_{DI}	0.2			V	(D+) – (D-)
Differential common-mode range	V_{CM}	0.8		2.5	V	Includes V_{DI} range
Single-ended receiver threshold	V_{SE}	0.8		2.0	V	
Receiver hysteresis	V_{RH}		200		mV	
Output low (driven)	V_{OL}	0		0.3	V	
Output high (driven)	V_{OH}	2.8		3.6	V	
Output signal cross voltage	V_{CRS}	1.3		2.0	V	
Pull-up resistor	R_{PU}	1.425		1.575	$k\Omega$	
Pull-down resistor	R_{PD}	14.25		15.75	$k\Omega$	
Termination Voltage for upstream port pull up (RPU)	V_{TRM}	3.0		3.6	V	

Table 5-6: Crystal Characteristics

Item	Symbol	Min	Typ.	Max	Unit	Condition
Input clock frequency	f_{XIN}		12		MHz	External crystal

5.4 I2C AC Characteristics

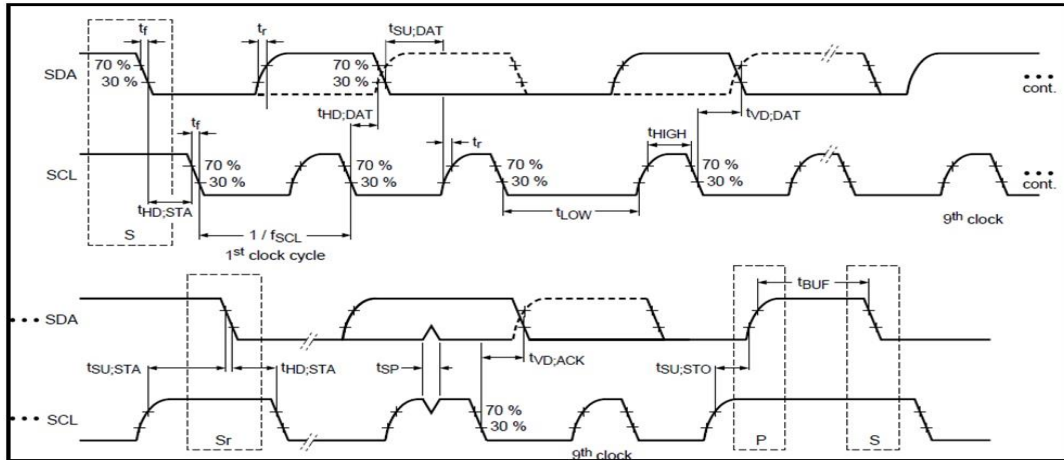

Table 5-7: I2C AC Characteristics

Parameter	Symbol	Standard-mode		Fast-mode		Unit
		Min	Max	Min	Max	
SCL clock frequency	f_{SCL}	0	100	0	400	kHz
Hold time START condition	$t_{HD:STA}$	4.0	-	0.6	-	us
LOW period of the SCL clock	t_{Low}	4.7	-	1.3	-	us
HIGH period of the SCL clock	t_{High}	4.0	-	0.6	-	us
Set-up time for a repeated START condition	$t_{SU:STA}$	4.7	-	0.6	-	us
Data hold time	$t_{HD:DAT}$	300	-	300	-	ns
Data set-up time	$t_{SU:DAT}$	250	-	100	-	ns
Rise time of both SDA and SCL signals (30% to 70%)	t_r	-	1000	20	300	ns
Fall time of both SDA and SCL signals (70% to 30%)	t_f	-	300	20	300	ns
Set-up time for STOP condition	$t_{SU:STO}$	4.0	-	0.6	-	us
Bus free time between a STOP and START condition	t_{BUF}	4.7	-	1.3	-	us
Capacitive load for each bus line	C_b	-	400	-	400	pF
Noise margin at the LOW level for each connected device	V_{nL}	$0.1V_{DD}$	-	$0.1V_{DD}$	-	V
Noise margin at the HIGH level for each connected device	V_{nH}	$0.2V_{DD}$	-	$0.2V_{DD}$	-	V

*SCL = I2C Host must to support clock stretching mode for using 400 kHz.

6. Power Sequence

6.1 Power-on Sequence

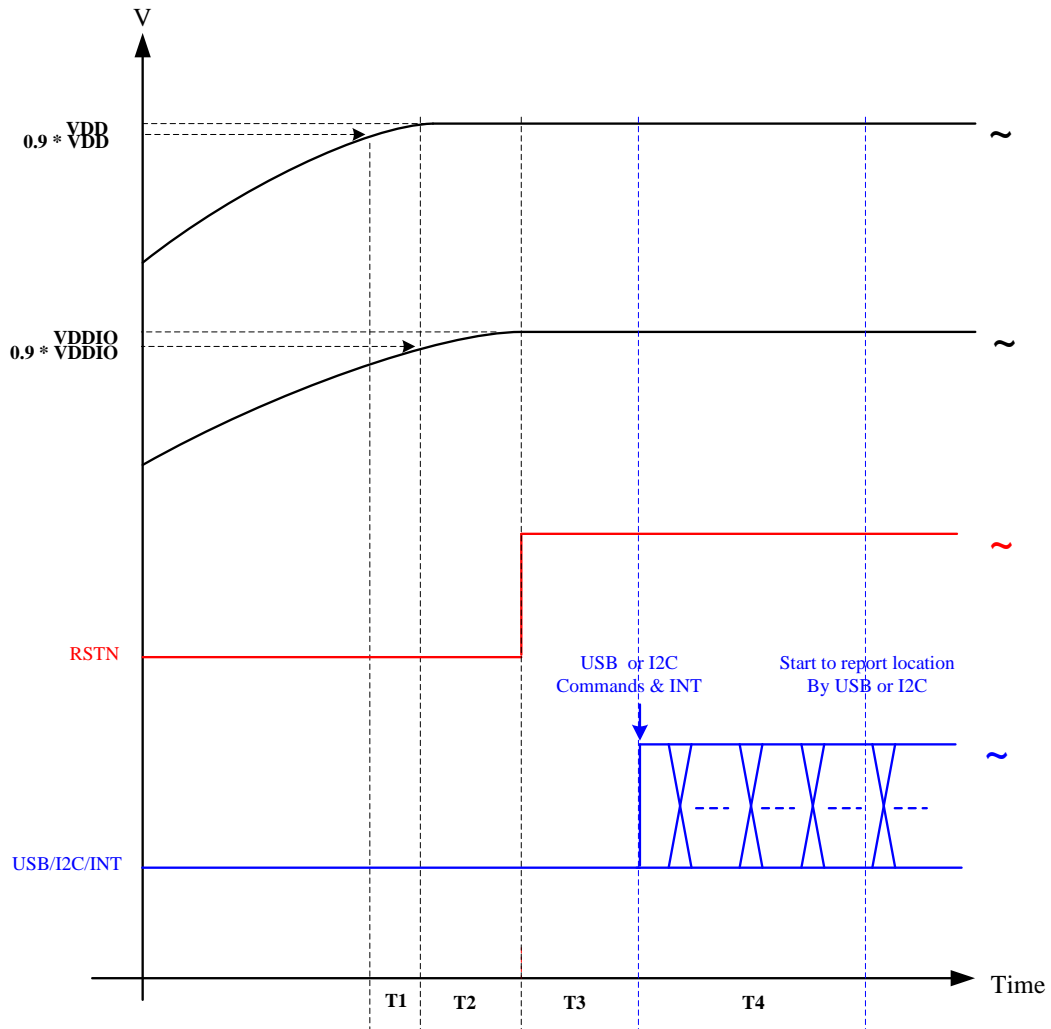

1. T1: the time difference between $0.9 \cdot VDD$ and $0.9 \cdot VDDIO$. T1 must be ≥ 0 sec.
2. T2: the time difference between $0.9 \cdot VDDIO$ and RSTN. T2 must be ≥ 200 us.
3. T3: the time difference between RSTN and Commands. T3 must be ≥ 150 ms.
4. T4: IC start to report point location to host. T4 must be ≥ 300 ms.

6.2 Power-off to Power-on Sequence

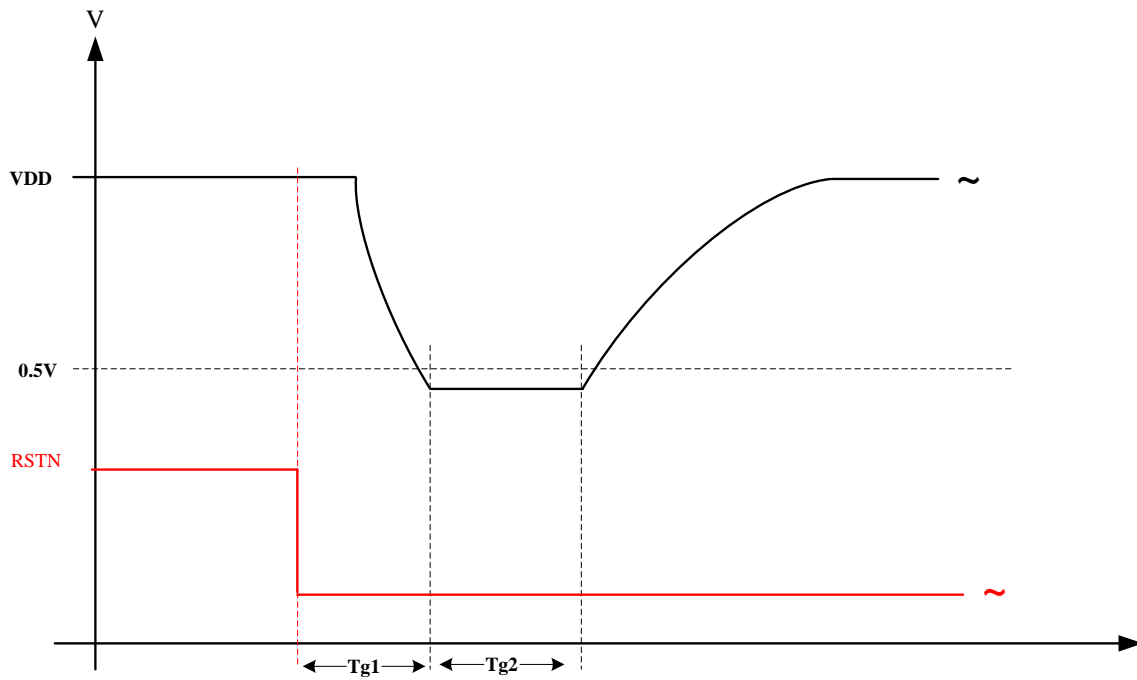

Tg1 : the time difference between power-off and power-on. Tg1 must be > 10us.

Tg2 : the time difference between power-off and power-on. Tg2 must be > 10us.

Note. During the power off time, the VDD must be lower than 0.5V that make sure the touch controller have been correctly reset.

7. Package Information

7.1 QFN-88 Package Dimension

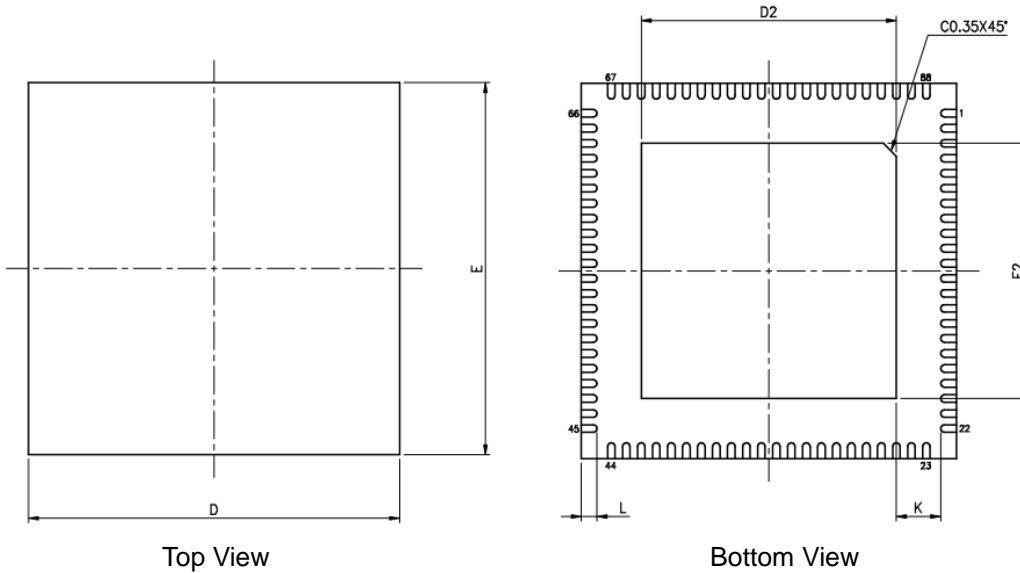

JEDEC OUTLINE	MO-220		
PKG CODE	WQFN(XA88)		
SYMBOLS	MIN.	NOM.	
A	0.70	0.75	0.80
A1	0.00	0.02	0.05
A3	0.203 REF.		
D	10.00 BSC		
E	10.00 BSC		
e	0.40 BSC		
L	0.30	0.40	0.50
K	0.20	—	—

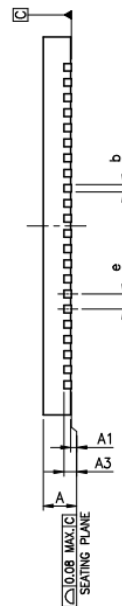

PAD SIZE	D2			E2			b			LEAD FINISH		JEDEC CODE
	MIN.	NOM.	MAX.	MIN.	NOM.	MAX.	MIN.	NOM.	MAX.	Pure Tin	PPF	
276X27* MIL	6.75	6.80	6.85	6.75	6.80	6.85	0.15	0.20	0.25	V	X	(W)VNNE-1

Figure 7-1: Package Information of QFN-88

7.2 Marking Information

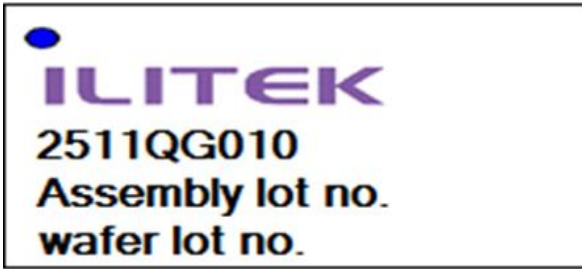

Column 1: ILITEK Logo

Column 2: Product Code

Code 1~4: Model Name

Code 5: Package Type, Q: QFN

Code 6~9: Package Fab Control Number

Column 3: Package Assembly Lot No

Column 4: Wafer Lot No

8. Typical Application Circuit

8.1 USB Application Circuit

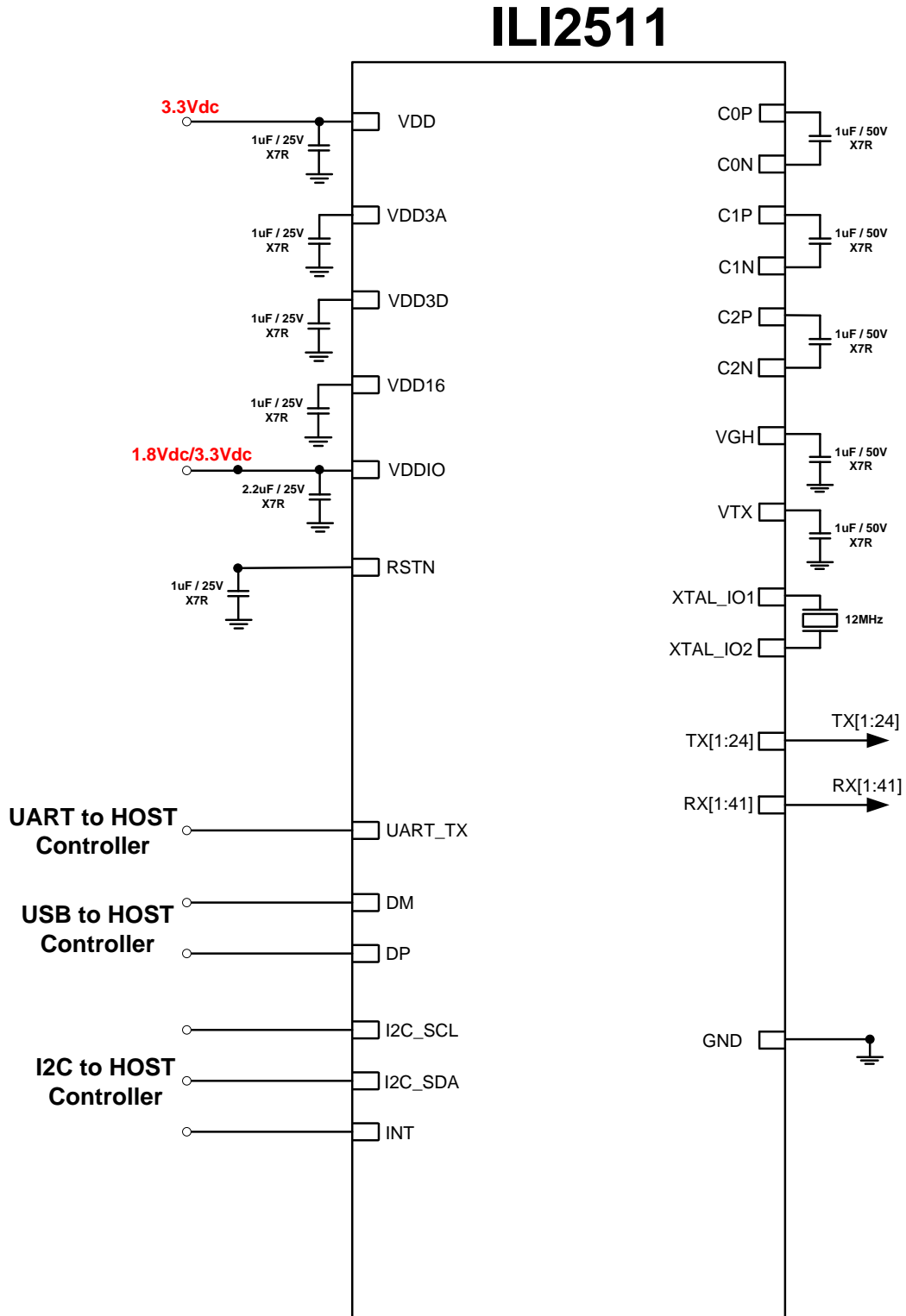

Figure 8-1: ILI2511 USB Application Circuit

8.2 I2C Application Circuit

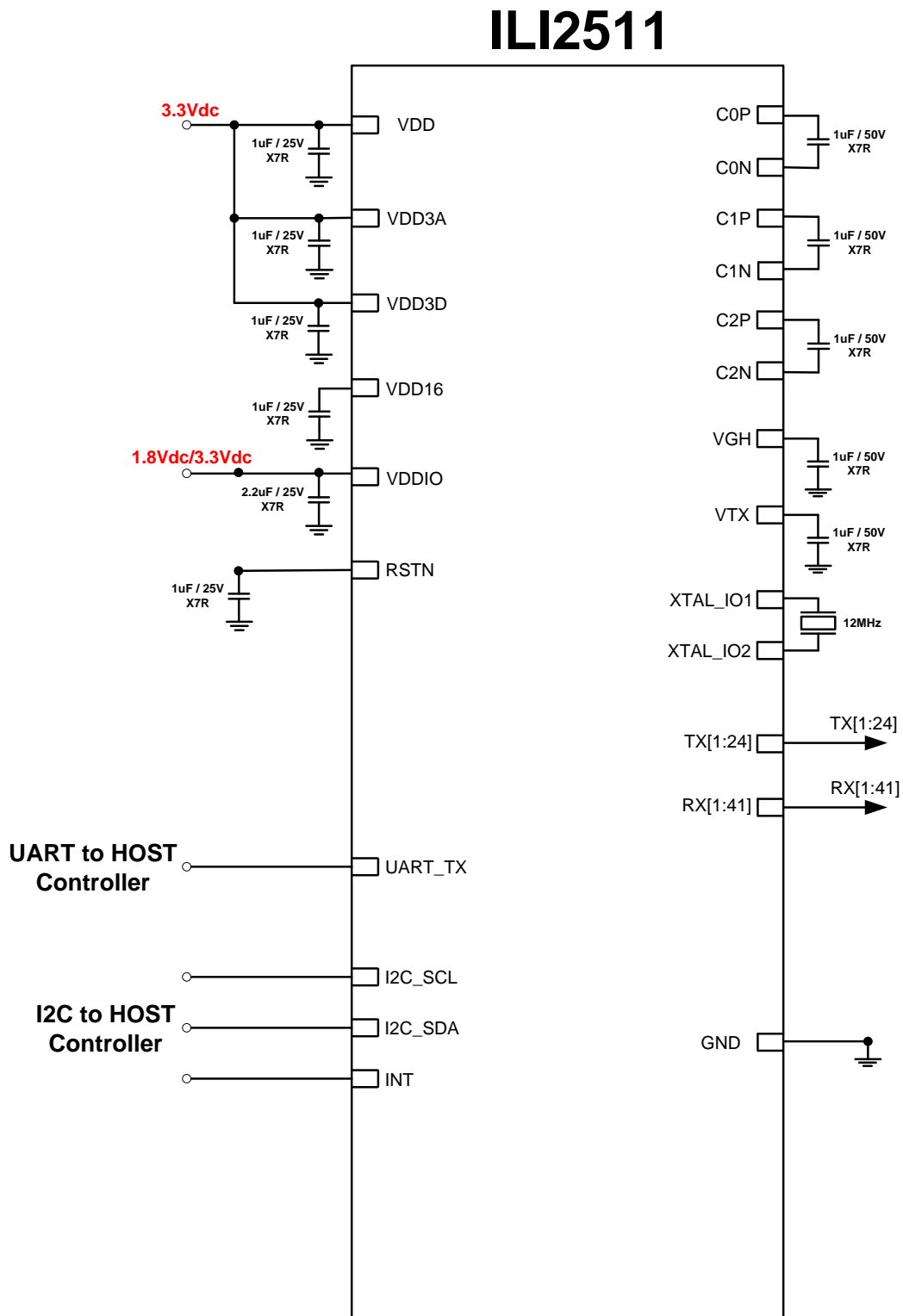

Figure 8-2: ILI2511 I2C Application Circuit