



## ePAPER DISPLAY MODULE DATASHEET



Datasheet Release 2021-04-20  
for  
**CFAP400300B1-0420**

Revision A0

### **Crystalfontz America, Inc.**

12412 East Saltese Avenue  
Spokane Valley, WA 99216-0357  
Phone: 888-206-9720  
Fax: 509-892-1203  
Email: [support@crystalfontz.com](mailto:support@crystalfontz.com)  
URL: [www.crystalfontz.com](http://www.crystalfontz.com)

## CONTENTS

1. General Information .....	3
2. Description Overview .....	4
3. Features .....	4
4. Mechanical Specifications .....	4
5. Input/Output Terminals .....	5
5.1. Pin Out List .....	5
6. Command Table .....	6
7. Electrical Characteristics .....	24
7.1. Absolute Maximum Rating .....	24
7.2. Panel DC Characteristics .....	24
7.3. Panel AC Characteristics .....	25
7.3.1. Oscillator Frequency .....	25
7.3.2. MCU Interface Selection .....	25
7.3.3. MCU Serial Interface (4-Wire SPI) .....	25
7.3.4. MCU Serial Interface (3-Wire SPI) .....	26
7.3.5. Timing Characteristics of Serial Interface .....	27
7.4. Power Consumption .....	28
7.5. Reference Circuit .....	28
8. Typical Operating Sequence .....	31
8.1. Normal Operation Flow .....	31
8.1.1. BWR Mode & LUT from Register .....	31
8.1.2. BWR Mode & LUT from OTP .....	32
8.2. Reference Program Code .....	33
8.2.1. BWR Mode & LUT from Register .....	33
8.2.2. BWR Mode & LUT from OTP .....	34
9. Optical Characteristics .....	35
9.1. Specifications .....	35
9.2. Definition of Contrast Ratio .....	35
9.3. Reflection Ratio .....	36
9.4. Bi-Stability .....	36
10. Mechanical Drawing .....	37
11. ePaper Breakout Board Schematic .....	38

## 1. General Information

### Datasheet Revision History

Datasheet Release Date: 2021-04-20  
Datasheet for the CFAP400300B1-0420 ePaper display module.

### Product Change Notifications

You can check for or subscribe to [Part Change Notices](#) for this display module on our website.

### Variations

Slight variations between lots are normal (e.g., contrast, color, or intensity).

### Volatility

This display module has volatile memory but is bistable.

### Disclaimer

Certain applications using Crystalfontz America, Inc. products may involve potential risks of death, personal injury, or severe property or environmental damage ("Critical Applications"). CRYSTALFONTZ AMERICA, INC. PRODUCTS ARE NOT DESIGNED, INTENDED, AUTHORIZED, OR WARRANTED TO BE SUITABLE FOR USE IN LIFE-SUPPORT APPLICATIONS, DEVICES OR SYSTEMS OR OTHER CRITICAL APPLICATIONS. Inclusion of Crystalfontz America, Inc. products in such applications is understood to be fully at the risk of the customer. In order to minimize risks associated with customer applications, adequate design and operating safeguards should be provided by the customer to minimize inherent or procedural hazard. Please contact us if you have any questions concerning potential risk applications.

Crystalfontz America, Inc. assumes no liability for applications assistance, customer product design, software performance, or infringements of patents or services described herein. Nor does Crystalfontz America, Inc. warrant or represent that any license, either express or implied, is granted under any patent right, copyright, or other intellectual property right of Crystalfontz America, Inc. covering or relating to any combination, machine, or process in which our products or services might be or are used.

All specifications in datasheets on our website are, to the best of our knowledge, accurate but not guaranteed. Corrections to specifications are made as any inaccuracies are discovered.

Company and product names mentioned in this publication are trademarks or registered trademarks of their respective owners.

Copyright © 2021 by Crystalfontz America, Inc., 12412 East Saltese Avenue, Spokane Valley, WA 99216 U.S.A.



## 2. Description Overview

This ePaper display has a 4.2" active area which contains 400x300 pixels and has 1-bit white/black full display capabilities. An integrated circuit contains a gate buffer, source buffer, interface, timing control logic, oscillator, DC-DC, SRAM, LUT, VCOM, and border are supplied with each panel.

## 3. Features

- High Contrast
- High Reflectance
- Ultra-Wide Viewing Angle
- Ultra-Low Power Consumption
- Pure Reflective Mode
- Bi-Stable Display
- Commercial Temperature Range
- Landscape or Portrait Mode
- Antiglare Hard-Coated Front-Surface
- Low Current Deep Sleep Mode
- On-Chip Display RAM
- Waveform Stored in On-Chip OTP
- SPI Available
- On-Chip Oscillator
- On-Chip Booster and Regulator Control for Generating VCOM, Gate and Source Driving Voltage
- I<sup>2</sup>C Signal Master Interface to Read External Temperature Sensor

## 4. Mechanical Specifications

Parameter	Specifications	Unit	Remark
Screen Size	4.2	inch	-
Display Resolution	400 (W) × 300 (H)	pixel	dpi: 120
Active Area	84.8 (W) × 63.6 (H)	mm	-
Pixel Pitch	0.212 × 0.212	mm	-
Pixel Configuration	Square	-	-
Outline Dimension	91.0 (W) × 77.0 (H) × 1.18 (D)	mm	-
Weight (typical)	14.0	g	-



## 5. Input/Output Terminals

### 5.1. Pin Out List

Pin #	Type	Symbol	Description
1	-	NC	No Connection and Do Not Connect with Other NC Pins, keep open.
2	O	GDR	N-Channel MOSFET Gate Drive Control
3	O	RESE	Current Sense Input for the Control Loop
4	C	VGL	Negative Gate Driving Voltage
5	C	VGH	Positive Gate Driving Voltage
6	O	TSCL	I <sup>2</sup> C Interface to Digital Temperature Sensor Clock Pin
7	I/O	TSDA	I <sup>2</sup> C Interface to Digital Temperature Sensor Data Pin
8	I	BS1	Bus Selection Pin – LOW for 4-wire SPI, HIGH for 3-wire SPI
9	O	BUSY	Busy State Output Pin - when BUSY is LOW, the operation of chip should not be interrupted and no commands should be issued to the module.
10	I	RES#	Reset signal input. Active low.
11	I	D/C#	Data /Command Control Pin connects to the MCU. When D/C# is HIGH data will be interpreted as data, when D/C is Low, data will be interpreted as a command.
12	I	CS#	Chip Select Input Pin indicates chip is enabled for MCU communication when CS# is LOW.
13	I/O	D0	Serial Clock Pin SCLK (SPI)
14	I/O	D1	Serial Data Pin SDIN (SPI)
15	I	VDDIO	Power for Interface Logic Pins
16	I	VCI	Power Supply Pin for Chip
17	-	VSS	Ground
18	C	VDD	Core Logic Power Pin
19	C	VPP	Power Supply for OTP Programming
20	C	VSH	Positive Source Driving Voltage
21	C	PREVGH	Positive Supply Pin for VGH and VSH
22	C	VSL	Negative Source Driving Voltage
23	C	PREVGL	Power Supply Pin for VCOM, VGL, and VSL
24	O	VCOM	VCOM Driving Voltage



## 6. Command Table

W/R: 0: Write cycle 1: Read cycle C/D: 0: Command 1: Data D7~D0: - : Don't care #: Valid Data

#	Command	W/R	C/D	D7	D6	D5	D4	D3	D2	D1	D0	Registers	Default	
1	Panel Setting (PSR)	0	0	0	0	0	0	0	0	0	0		00h	
		0	1	#	#	#	#	#	#	#	#	RES[1:0],REG,KW/R,UD, SHL, SHD_N, RST_N	0Fh	
2	Power Setting (PWR)	0	0	0	0	0	0	0	0	0	1		01h	
		0	1	-	-	-	-	-	-	-	#	#	VDS_EN,V DG_EN	03h
		0	1	-	-	-	-	-	#	#	#	#	VCOM_HV, VGHL_LV[1:0]	00h
		0	1	-	-	#	#	#	#	#	#	#	VDH[5:0]	26h
		0	1	-	-	#	#	#	#	#	#	#	VDL[5:0]	26h
		0	1	-	-	#	#	#	#	#	#	#	VDHR[5:0]	03h
3	Power OFF(POF)	0	0	0	0	0	0	0	0	1	0		02h	
4	Power OFF Sequence Setting (PFS)	0	0	0	0	0	0	0	0	1	1		03h	
		0	1	-	-	#	#	-	-	-	-	-	T_VDS_OF	00h
5	Power ON (PON)	0	0	0	0	0	0	0	1	0	0		04h	
6	Power ON Measure (PMES)	0	0	0	0	0	0	0	1	0	1		05h	
7	Booster Soft Start (BTST)	0	0	0	0	0	0	0	1	1	0		06h	
		0	1	#	#	#	#	#	#	#	#	#	BT_PHA[7:0]	17h
		0	1	#	#	#	#	#	#	#	#	#	BT_PHB[7:0]	17h
		0	1	-	-	#	#	#	#	#	#	#	BT_PHC[5:0]	17h
8	Deep Sleep (DSL P)	0	0	0	0	0	0	0	1	1	1		07h	
		0	1	1	0	1	0	0	1	0	1	1	Check Code	A5h
9	Display Start Transmission 1 (DTM1, old data) (x-byte command)	0	0	0	0	0	1	0	0	0	0	B/W Pixel Data (400x300)	10h	
		0	1	#	#	#	#	#	#	#	#	#	KPXL[1:8]	00h
		0	1	..	..	..	..	..	..	..	..	..	..	...
		0	1	#	#	#	#	#	#	#	#	#	KPXL[n-1:n]	00h
10	Data Stop (DSP)	0	0	0	0	0	1	0	0	0	1		11h	
		1	1	#	-	-	-	-	-	-	-	-		00h
11	Display Refresh (DRF)	0	0	0	0	0	1	0	0	1	0		12h	
12	Image Process Command (IPC)	0	0	0	0	0	1	0	0	1	1		13h	
		0	1	-	-	-	#	-	#	#	#	#	IP_EN_IP_SEL[2:0]	00h



#	Command	W/R	C/D	D7	D6	D5	D4	D3	D2	D1	D0	Registers	Default	
13	VCOM LUT (LUTC) (45-byte command, structure of bytes 2~7 repeated)	0	0	0	0	1	0	0	0	0	0		20h	
14	W2W LUT (LUTWW) (43-byte command, structure of bytes 2~7 repeated 7 times)	0	0	0	0	1	0	0	0	0	1		21h	
15	B2W LUT (LUTBW / LUTR) (43-byte command, structure of bytes 2~7 repeated 7 times)	0	0	0	0	1	0	0	0	1	0		22h	
16	W2B LUT (LUTWB / LUTW) (43-byte command, structure of bytes 2~7 repeated 7 times)	0	0	0	0	1	0	0	0	1	1		23h	
17	B2B LUT (LUTBB / LUTB) (43-byte command, structure of bytes 2~7 repeated 7 times)	0	0	0	0	1	0	0	1	0	0		24h	
18	PLL Control (PLL)	0	0	0	0	1	1	0	0	0	0		30h	
		0	1	-	-	#	#	#	#	#	#	#	M[2:0], N[2:0]	3Ch
19	Temperature Sensor Calibration (TSC)	0	0	0	1	0	0	0	0	0	0		40h	
		1	1	#	#	#	#	#	#	#	#	LM[10:3]/TSR[7:0]	00h	
		1	1	#	#	#	-	-	-	-	-	-	LM[2:0]/-	00h
20	Temperature Sensor Selection (TSE)	0	0	0	1	0	0	0	0	0	1		41h	
		0	1	#	-	-	-	#	#	#	#	#	TSE, TO[3:0]	00h
21	Temperature Sensor Write (TSW)	0	0	0	1	0	0	0	0	1	0		42h	
		0	1	#	#	#	#	#	#	#	#	#	WATTR[7:0]	00h
		0	1	#	#	#	#	#	#	#	#	#	WMSB[7:0]	00h
		0	1	#	#	#	#	#	#	#	#	#	WLSB[7:0]	00h
22	Temperature Sensor Read	0	0	0	1	0	0	0	0	1	1		43h	



#	Command	W/R	C/D	D7	D6	D5	D4	D3	D2	D1	D0	Registers	Default
		1	1	#	#	#	#	#	#	#	#	RMSB[7:0]	00h
		1	1	#	#	#	#	#	#	#	#	RLSB[7:0]	00h
23	VCOM and Data Interval Setting (CDI)	0	0	0	1	0	1	0	0	0	0		50h
		0	1	#	#	#	#	#	#	#	#	VBD[1:0],DDX[1:0],CDI[3:0]	D7h
24	Low Power Detection (LPD)	0	0	0	1	0	1	0	0	0	1		51h
		1	1	-	-	-	-	-	-	-	-	LPD	01h
25	TCON Setting (TCON)	0	0	0	1	1	0	0	0	0	0		60h
		0	1	#	#	#	#	#	#	#	#	S2G[3:0],G2S[3:0]	22h
26	Resolution Setting (TRES)	0	0	0	1	1	0	0	0	0	1		61h
				#	#	#	#	#	0	0	0	HRES[7:3]	00h
		0	1	-	-	-	-	-	-	-	-	VRES[8:0]	00h
		0	1	#	#	#	#	#	#	#	#		00h
27	GSST Status (GSST)	0	0	0	1	1	0	0	1	0	1		65h
		0	1	-	-	-	-	-	-	-	-	HST[8:3]	00h
		0	1	#	#	#	#	#	0	0	0		00h
		0	1	-	-	-	-	-	-	-	-	VST[8:0]	00h
		0	1	#	#	#	#	#	#	#	#		00h
28	Get Status (FLG)	0	0	0	1	1	1	0	0	0	1		71h
		1	1	-	#	#	#	#	#	#	#	PTL_FLAG,I <sup>2</sup> C,BUSY,DATA_FLAG,PON,POF,BUSY	02h
29	Auto Measurement VCOM (AMV)	0	0	1	0	0	0	0	0	0	0		80h
		0	1	-	-	#	#	#	#	#	#	AMVT[1:0], XON, AMVS, AMV, AMVE	10h
30	Read VCOM Value (VV)	0	0	1	0	0	0	0	0	0	1		81h
		1	1	-	-	#	#	#	#	#	#	VV[5:0]	00h
31	VCM_DC Setting (VDCS)	0	0	1	0	0	0	0	0	1	0		82h
		0	1	-	-	#	#	#	#	#	#	VDCS[5:0]	00h
32	Partial Window (PTL)	0	0	1	0	0	1	0	0	0	0		90h
		0	1	-	-	-	-	-	-	-	-	HRST[8:3]	00h
		0	1	#	#	#	#	#	0	0	0		00h
		0	1	-	-	-	-	-	-	-	-	HRED[8:3]	00h
		0	1	#	#	#	#	#	1	1	1		07h
		0	1	-	-	-	-	-	-	-	-	VRST[8:0]	00h
		0	1	#	#	#	#	#	#	#	#		00h





#	Command	W/R	C/D	D7	D6	D5	D4	D3	D2	D1	D0	Registers	Default	
		0	1	-	-	-	-	-	-	-	#	VRED[8:0]	00h	
		0	1	#	#	#	#	#	#	#	#		00h	
		0	1	-	-	-	-	-	-	-	-	#	PT_SCAN	01h
33	Partial In (PTIN)	0	0	1	0	0	1	0	0	0	1		91h	
34	Partial Out (PTOUT)	0	0	1	0	0	1	0	0	1	0		92h	
35	Program Mode (PGM)	0	0	1	0	1	0	0	0	0	0		A0h	
		0	1	1	0	1	0	0	1	0	1	Check Code = A5h	A5h	
36	Active Program (APG)	0	0	1	0	1	0	0	0	0	1		A1h	
37	Read OTP (ROTP)	0	0	1	0	1	0	0	0	1	0		A2h	
		1	1	-	-	-	-	-	-	-	-	-	Read Dummy	N/A
		1	1	#	#	#	#	#	#	#	#	#	Data of Address = 000h	N/A
		1	1	..	..	..	..	..	..	..	..	..	..	N/A
		1	1	#	#	#	#	#	#	#	#	#	Data of Address = n	N/A
38	Power Saving (PWS)	0	0	1	1	1	0	0	0	1	1		E3h	
		0	1	#	#	#	#	#	#	#	#	#	VCOM_W[3:0],SD_W[3:0]	00h

**(1) Panel Setting (PSR) (Register: R00H)**

Action	W/R	C/D	D7	D6	D5	D4	D3	D2	D1	D0
Setting the panel	0	0	0	0	0	0	0	0	0	0
	0	1	RES1	RES0	REG_EN	BWR	UD	SHL	SHD_N	RST_N

RES [1:0]: Display Resolution setting (source x gate)

00b: 400x300 (Default)      Active source channels: S0~S399. Active gate channels: G0~G299.  
 01b: 320x300                Active source channels: S0~S319. Active gate channels: G0~G299.  
 10b: 320x240                Active source channels: S0~S319. Active gate channels: G0~G239.  
 11b: 200x300                Active source channels: S0~S199. Active gate channels: G0~G299.

REG\_EN: LUT selection

0: LUT from OTP. (Default)  
 1: LUT from register

BWR: Black / White / Red

0: Pixel with B/W/Red. (Default)  
 1: Pixel with B/W.

UD: Gate Scan Direction

0: Scan down.                First line to last line: Gn-1 → Gn-2 → Gn-3 →...→ G0  
 1: Scan up. (Default)      First line to last line: G0 → G1 → G2 →...→ Gn-1

SHL: Source Shift direction

0: Shift left.                First data to last data: Sn-1 → Sn-2 → Sn-3 →...→ S0  
 1: Shift right. (Default)    First data to last data: S0 → S1 → S2 →...→ Sn-1

SHD\_N: Booster Switch

0: Booster OFF, register data are kept, and SEG/BG/VCOM are kept 0V or floating.  
 1: Booster ON (Default)

When SHD\_N becomes LOW, charge pump will be turned OFF, register and SRAM data will keep until VDD OFF, and SD output and VCOM will be based on previous condition and keep floating. SHD\_N may have two conditions: 0V or floating.

RST\_N: Soft Reset

0: No effect. (Default)    Booster OFF, Register data are set to their default values, and SEG/BG/VCOM: 0V.

When RST\_N becomes LOW, the driver will be reset; all registers will be reset to their default value. All driver functions will be disabled. SD output and VCOM will be based on previous condition. It may have two conditions: 0V and floating.

**(2) Power Setting (PWR) (R01H)**

Action	W/R	C/D	D7	D6	D5	D4	D3	D2	D1	D0
Selecting Internal/External Power	0	0	0	0	0	0	0	0	0	1
	0	1	-	-	-	-	-	-	VDS_EN	VDG_EN
	0	1	-	-	-	-	-	VCOM_HV	VGHL_LV[1:0]	
	0	1	-	-	VDH[5:0]					
	0	1	-	-	VDL[5:0]					
	0	1	-	-	VDHR[5:0]					



VDS\_EN: Source power selection  
 0: External source power from VDH/VDL pins  
 1: Internal DC/DC function for generating VDH/VDL

VDG\_EN: Gate power selection  
 0: External gate power from VGH/VGL pins  
 1: Internal DC/DC function for generating VGH/VGL

VCOM\_HV: VCOM Voltage Level  
 0: VCOMH=VDH+VCOMDC, VCOML=VDL+VCOMDC  
 1: VCOML=VGH, VCOML=VGL

VGHL\_LV [1:0]: VGH / VGL Voltage Level selection

VGHL_LV	VGHL Voltage Level
00(Default)	VGH=16V, VGL= -16V
01	VGH=15V, VGL= -15V
10	VGH=14V, VGL= -14V
11	VGH=13V, VGL= -13V

VDH [5:0]: Internal VDH power selection for B/W pixel. (Default value: 100110b)

VDH	VDH_V	VDH	VDH_V
000000	2.4V	...	...
000001	2.6V	100110	10.0V
000010	2.8V	100111	10.2V
000011	3.0V	101000	10.4V
000100	3.2V	101001	10.6V
000101	3.4V	101010	10.8V
000110	3.6V	101011	11.0V
000111	3.8V	(others)	11.0V

VDL [5:0]: Internal VDL power selection for B/W pixel. (Default value: 100110b)

VDL	VDL_V	VDL	VDL_V
000000	-2.4V	...	...
000001	-2.6V	100110	-10.0V
000010	-2.8V	100111	-10.2V
000011	-3.0V	101000	-10.4V
000100	-3.2V	101001	-10.6V
000101	-3.4V	101010	-10.8V
000110	-3.6V	101011	-11.0V
000111	-3.8V	(others)	-11.0V

**(3) Power OFF (PWR) (R02H)**

Action	W/R	C/D	D7	D6	D5	D4	D3	D2	D1	D0
Turning OFF the power	0	0	0	0	0	0	0	0	1	0

After the Power Off command, the driver will power off following the Power Off Sequence. This command will turn off the charge pump, T-CON, source driver, gate driver, VCOM, and temperature sensor, but register data will be kept until VDD becomes OFF.

Source Driver output and VCOM will remain as the previous condition, which may have 2 conditions: 0V or floating.

**(4) Power OFF Sequence Setting (PFS) (R03H)**

Action	W/R	C/D	D7	D6	D5	D4	D3	D2	D1	D0
Setting Power OFF sequence	0	0	0	0	0	0	0	0	1	1
	0	1	-	-	T_VDS_OFF[1:0]	-	-	-	-	-

T\_VDS\_OFF [1:0]: Power OFF Sequence of VD<sub>H</sub> and VD<sub>L</sub>

00b:1 frame (Default) 01b:2 frames 10b: 3 frames 11b:4 frames

**(5) Power ON (PON) (R04H)**

Action	W/R	C/D	D7	D6	D5	D4	D3	D2	D1	D0
Turning ON the Power	0	0	0	0	0	0	0	1	0	0

After the Power ON command, the driver will be powered ON following the Power ON Sequence. Refer to the Power ON Sequence section. In the sequence, the temperature sensor will be activated for one-time sensing before enabling the booster.

**(6) Power ON Measure (PMES) (R05H)**

Action	W/R	C/D	D7	D6	D5	D4	D3	D2	D1	D0
Power ON Measure	0	0	0	0	0	0	0	1	0	1

This command enables the internal bandgap that will be cleared by the next POF.

**(7) Booster Soft Start (BTST) (R06H)**

Action	W/R	C/D	D7	D6	D5	D4	D3	D2	D1	D0
Starting Data Transmission	0	0	0	0	0	0	0	1	1	0
	0	1	BT_PHA 7	BT_PHA 6	BT_PHA 5	BT_PHA 4	BT_PHA 3	BT_PHA 2	BT_PHA 1	BT_PHA 0
	0	1	BT_PHB 7	BT_PHB 6	BT_PHB 5	BT_PHB 4	BT_PHB 3	BT_PHB 2	BT_PHB 1	BT_PHB 0
	0	1	-	-	BT_PHC 5	BT_PHC 4	BT_PHC 3	BT_PHC 2	BT_PHC 1	BT_PHC 0

BTPHA [7:6]: Soft start period of phase A.

**00b: 10mS** 01b: 20mS 10b: 30mS 11b: 40mS

BTPHA [5:3]: Driving strength of phase A.

000b: strength 1      001b: strength 2      **010b: strength 3**  
 011b: strength 4      100b: strength 5      101b: strength 6  
 110b: strength 7      111b: strength 8 (strongest)

BTPHA [2:0]: Minimum OFF time setting of GDR in phase B  
 000b: 0.27uS 001b: 0.34uS 010b: 0.40uS 011b: 0.54uS  
 100b: 0.80uS 101b: 1.54uS 110b: 3.34uS **111b: 6.58uS**

BTPHB [7:6]: Soft start period of phase B.  
**00b: 10mS** 01b: 20mS 10b: 30mS 11b: 40mS

BTPHB [5:3]: Driving strength of phase B  
 000b: strength 1 001b: strength 2 **010b: strength 3**  
 011b: strength4 100b: strength 5 101b: strength 6  
 110b: strength 7 111b: strength 8 (strongest)

BTPHB [2:0]: Minimum OFF time setting of GDR in phase B  
 000b: 0.27uS 001b: 0.34uS 010b: 0.40uS 011b: 0.54uS  
 100b: 0.80uS 101b: 1.54uS 110b: 3.34uS **111b: 6.58uS**

BTPHC [5:3]: Driving strength of phase C  
 000b: strength 1 001b: strength 2 **010b: strength 3**  
 011b: strength4 100b: strength 5 101b: strength 6  
 110b: strength 7 111b: strength 8 (strongest)

BTPHC [2:0]: Minimum OFF time setting of GDR in phase C  
 000b: 0.27uS 001b: 0.34uS 010b: 0.40uS 011b: 0.54uS  
 100b: 0.80uS 101b: 1.54uS 110b: 3.34uS **111b: 6.58uS**

(8) Deep Sleep (DSLPL) (R07H)

Action	W/R	C/D	D7	D6	D5	D4	D3	D2	D1	D0
Deep Sleep	0	0	0	0	0	0	0	1	1	1
	0	1	1	0	1	0	0	1	0	1

After this command is transmitted, the chip would enter the deep-sleep mode to save power.  
 The deep sleep mode would return to standby by hardware reset.  
 The only one parameter is a check code, the command would be executed if check code = 0xA5.

(9) Data Start Transmission 1 (R10H)

Action	W/R	C/D	D7	D6	D5	D4	D3	D2	D1	D0
Starting Data Transmission	0	0	0	0	0	1	0	0	0	0
	0	1	Pixel1	Pixel2	Pixel3	Pixel4	Pixel5	Pixel6	Pixel7	Pixel8
	0	1	..	..	..	..	..	..	..	..
	0	1	Pixel(n-7)	Pixel(n-6)	Pixel(n-5)	Pixel(n-4)	Pixel(n-3)	Pixel(n-2)	Pixel(n-1)	Pixel(n)

This command starts transmitting data and writes the data to SRAM. To complete data transmission, command DSP (Data Transmission Stop) must be issued. Then the chip will start to send data/VCOM for panel.

- In B/W mode, this command writes "OLD" data to SRAM.
- In B/W/Red mode, this command writes "B/W" data to SRAM.
- In Program mode, this command writes "OTP" data to SRAM for programming.

(10) Data Stop (DSP) (R11H)

Action	W/R	C/D	D7	D6	D5	D4	D3	D2	D1	D0
Stopping Data Transmission	0	0	0	0	0	1	0	0	0	1
	1	1	Data_flag	-	-	-	-	-	-	-

To stop data transmission, this command must be issued to check the data\_flag.

Data\_flag: Data flag of receiving user data.

0: Driver didn't receive all the data.

1: Driver has already received all the one-frame data (DTM1 and DTM2).

After "Data Start" (R10H) or "Data Stop" (R11H) commands and when data\_flag=1, the refreshing of the panel starts and the BUSY signal will become "0".

(11) Display Refresh Command (R12H)

Action	W/R	C/D	D7	D6	D5	D4	D3	D2	D1	D0
Refreshing the Display	0	0	0	0	0	1	0	0	1	0

After this command is issued, the driver will refresh the display (data/VCOM) according to SRAM data and LUT. After Display Refresh command, BUSY signal will become "0" and the refreshing of the panel starts.

(12) Image Process Command (IPC) (R13H)

Action	W/R	C/D	D7	D6	D5	D4	D3	D2	D1	D0
Image Process Setting	0	0	0	0	1	0	0	0	1	1
	0	1	-	-	-	IP_EN	-	IP_SEL[2:0]		

After this command is issued, image process engine will find thin lines/pixels from frame SRAM and update the frame SRAM for applying new gray level waveform.

IP\_EN: Image process enabled.

0: No action

1: Image process enabled (auto return to "0" after image process is finished)

IP\_SEL[2:0]: Image process selection.

000: Deal with 1-pixel width

001: Deal with 2-pixel width

010: Deal with 3-pixel width

011: Deal with 1-pixel and 2-pixel width

100: Deal with 1-pixel, 2-pixel, and 3-pixel width

Others: Deal with 1-pixel width

After "Image Process Command" (13H), BUSY signal will be low until image process is finished.

(13) VCOM LUT (LUTC) (R20H)

This command builds the Look-up Table for VCOM.

(14) W2W LUT (LUTWW) (R21H)

This command builds the Look-up Table for White-to-White.

(15) B2W LUT (LUTBW/LUTR) (R22H)

This command builds the Look-up Table for Black-to-White.

(16) W2B LUT (LUTWB/LUTW) (R23H)

This command builds the Look-up Table for White-to-Black.

(17) B2B LUT (LUTBB / LUTB) (R24H)

This command builds the Look-up Table for Black-to-Black.

(18) PLL Control (PLL) (R30H)

Action	W/R	C/D	D7	D6	D5	D4	D3	D2	D1	D0
Controlling PLL	0	0	0	0	1	1	0	0	0	0
	0	1	-	-	M[2:0]			N[2:0]		

This command controls the PLL clock frequency.

The PLL structure must support the following frame rates:

M	N	Frame Rate	M	N	Frame Rate	M	N	Frame Rate	M	N	Frame Rate
1	1	29 Hz	3	1	86 Hz	5	1	150 Hz	7	1	200 Hz
	2	14 Hz		2	43 Hz		2	72 Hz		2	100 Hz
	3	10 Hz		3	29 Hz		3	48 Hz		3	67 Hz
	4	7 Hz		4	21 Hz		4	36 Hz		4	50 Hz (Default)
	5	6 Hz		5	17 Hz		5	29 Hz		5	40 Hz
	6	5 Hz		6	14 Hz		6	24 Hz		6	33 Hz
	7	4 Hz		7	12 Hz		7	20 Hz		7	29 Hz
2	1	57 Hz	4	1	114 Hz	6	1	171 Hz			
	2	29 Hz		2	57 Hz		2	86 Hz			
	3	19 Hz		3	38 Hz		3	57 Hz			
	4	14 Hz		4	29 Hz		4	43 Hz			
	5	11 Hz		5	23 Hz		5	34 Hz			
	6	10 Hz		6	19 Hz		6	29 Hz			
	7	8 Hz		7	16 Hz		7	24 Hz			

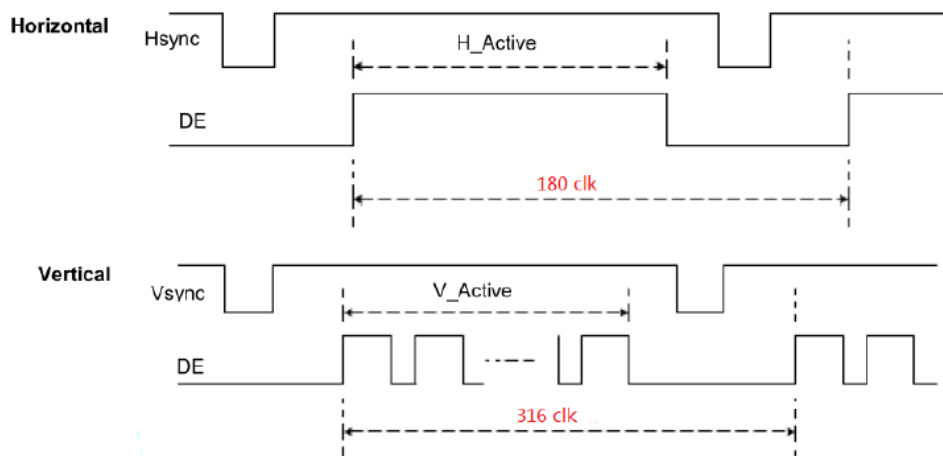

#### (19) Temperature Sensor Calibration (TSC) (R40H)

Action	W/R	C/D	D7	D6	D5	D4	D3	D2	D1	D0
Sensing Temperature	0	0	0	1	0	0	0	0	0	0
	1	1	D10/TS7	D9/TS6	D8/TS5	D7/TS4	D6/TS3	D5/TS2	D4/TS1	D3/TS0
	1	1	D2	D1	D0	-	-	-	-	-

This command reads the temperature sensed by the temperature sensor.

TS [7:0]: When TSE (R41h) is set to 0, this command reads the internal temperature sensor value.

D [10:0]: When TSE (R41h) is set to 1, this command reads the external LM75 temperature sensor value.

TS[7:0]/D[10:3]	Temperature (°C)	TS[7:0]/D[10:3]	Temperature (°C)	TS[7:0]/D[10:3]	Temperature (°C)
1110_0111	-25	0000_0000	0	0001_1001	25
1110_1000	-24	0000_0001	1	0001_1010	26
1110_1001	-23	0000_0010	2	0001_1011	27
1110_1010	-22	0000_0011	3	0001_1100	28
1110_1011	-21	0000_0100	4	0001_1101	29
1110_1100	-20	0000_0101	5	0001_1110	30
1110_1101	-19	0000_0110	6	0001_1111	31
1110_1110	-18	0000_0111	7	0010_0000	32



1110_1111	-17	0000_1000	8	0010_0001	33
1111_0000	-16	0000_1001	9	0010_0010	34
1111_0001	-15	0000_1010	10	0010_0011	35
1111_0010	-14	0000_1011	11	0010_0100	36
1111_0011	-13	0000_1100	12	0010_0101	37
1111_0100	-12	0000_1101	13	0010_0110	38
1111_0101	-11	0000_1110	14	0010_0111	39
1111_0110	-10	0000_1111	15	0010_1000	40
1111_0111	-9	0001_0000	16	0010_1001	41
1111_1000	-8	0001_0001	17	0010_1010	42
1111_1001	-7	0001_0010	18	0010_1011	43
1111_1010	-6	0001_0011	19	0010_1100	44
1111_1011	-5	0001_0100	20	0010_1101	45
1111_1100	-4	0001_0101	21	0010_1110	46
1111_1101	-3	0001_0110	22	0010_1111	47
1111_1110	-2	0001_0111	23	0011_0000	48
1111_1111	-1	0001_1000	24	0011_0001	49

(20) Temperature Sensor Enable (TSE) (R41H)

Action	W/R	C/D	D7	D6	D5	D4	D3	D2	D1	D0
Enable Temperature Sensor/Offset	0	0	0	1	0	0	0	0	0	1
	0	1	TSE	-	-	-	TO[3:0]			

This command selects the Internal and External temperature sensor.

TSE: Internal temperature sensor switch

0: Enable (Default)      1: Disable; using external sensor.

TO[3:0] Temperature offset.

TO[3:0]	Calculation	TO[3:0]	Calculation
0000 b	0	1000	-8
0001	1	1001	-7
0010	2	1010	-6
...	...	...	...
0110	6	1110	-2
0111	7	1111	-1

(21) Temperature Sensor Write (TSW) (R42H)

Action	W/R	C/D	D7	D6	D5	D4	D3	D2	D1	D0
Write External Temperature Sensor	0	0	0	1	0	0	0	0	1	0
	0	1	WATTR[7:0]							
	0	1	WMSB[7:0]							
	0	1	WLSB[7:0]							



This command reads the temperature sensed by the temperature sensor.

WATTR: D[7:6] I<sup>2</sup>C Write Byte Number

00b: 1 byte (head byte only)

01b: 2 bytes (head byte + pointer)

10b: 3 bytes (head byte + pointer + 1st parameter)

11b: 4 bytes (head byte + pointer + 1st parameter + 2nd parameter)

D[5:3]: User-defined address bits (A2, A1, A0)

D[2:0]: Pointer setting

WMSB[7:0]: MSByte of write-data to external temperature sensor.

WLSB[7:0]: LSByte of write-data to external temperature sensor.

#### (22) Temperature Sensor Read (TSR) (R43H)

Action	W/R	C/D	D7	D6	D5	D4	D3	D2	D1	D0
Read External Temperature Sensor	0	0	0	1	0	0	0	0	1	1
	1	1	RMSB[7:0]							
	1	1	RLSB[7:0]							

This command reads the temperature sensed by the temperature sensor.

RMSB[7:0]: MSByte read data from external temperature sensor.

RLSB[7:0]: LSByte read data from external temperature sensor.

#### (23) VCOM and Data Interval Setting (CDI) (R50H)

Action	W/R	C/D	D7	D6	D5	D4	D3	D2	D1	D0
Set Interval Between VCOM and Data	0	0	0	1	0	1	0	0	0	0
	0	1	VBD[1:0]		DDX[1:0]		CDI[3:0]			

This command indicates the interval of VCOM and data output. When setting the vertical back porch, the total blanking will be kept (20 H<sub>SYNC</sub>).

#### B/W mode (BWR=1)

DDX[0]	VBD[1:0]	LUT	DDX[0]	VBD[1:0]	LUT
0	00	Floating	1 (Default)	00	Floating
	01	LUTBW (1 → 0)		01	LUTWB (1 → 0)
	10	LUTWB (0 → 1)		10	LUTBW (0 → 1)
	11	Floating		11	Floating

DDX[1:0]: Display polarity.

DDX[1] for RED data, DDX[0] for BW data on the B/W/Red mode.

DDX[0] for B/W mode.

#### B/W mode (BWR=1)

DDX[0]	Data {New, Old}	LUT	DDX[0]	Data {New, Old}	LUT
00	00	LUTWW (0 → 0)	10	0	LUTBW (1 → 0)
	01	LUTBW (1 → 0)		1	LUTWB (0 → 1)
	10	LUTWB (0 → 1)	11	0	LUTWB (1 → 0)
	11	LUTBB (1 → 1)		1	LUTBW (0 → 1)
01(Default)	00	LUTBB (0 → 0)			
	01	LUTWB (0 → 1)			

	10	LUTBW (1 → 0)
	11	LUTWW (1 → 1)

**CDI[3:0]: VCOM and Data Interval**

CDI[3:0]	VCOM and Data Interval	CDI[3:0]	VCOM and Data Interval
0000 b	17 H <sub>SYNC</sub>	0110	11
0001	16	0111	10 (Default)
0010	15	...	...
0011	14	1101	4
0100	13	1110	3
0101	12	1111	2

**(24) Low Power Detection (LPD) (R51H)**

Action	W/R	C/D	D7	D6	D5	D4	D3	D2	D1	D0
Detect Low Power	0	0	0	1	0	1	0	0	0	1
	1	1	-	-	-	-	-	-	-	LPD

This command indicates the input power condition. Host can read this flag to learn the condition of the battery.

LPD: Interval Low Power Detection Flag

0: Low Power Input (VDD<2.5V)      1: Normal Status (Default)

**(25) TCON Setting (TCON) (R60H)**

Action	W/R	C/D	D7	D6	D5	D4	D3	D2	D1	D0
Set Gate/Source Non-Overlap Period	0	0	0	1	1	0	0	0	0	0
	0	1	S2G[3:0]				G2S[3:0]			

This command defines the non-overlap period of Gate and Source.

**S2G[3:0] or G2S[3:0]: Source to Gate / Gate to Source Non-overlap Period**

S2G[3:0] or G2S[3:0]	Period	S2G[3:0] or G2S[3:0]	Period
0000 b	4	...	...
0001	8	1011	48
0010	12 (Default)	1100	52
0011	16	1101	56
0100	20	1110	60
0101	24	1111	64

Period = 660 nS.

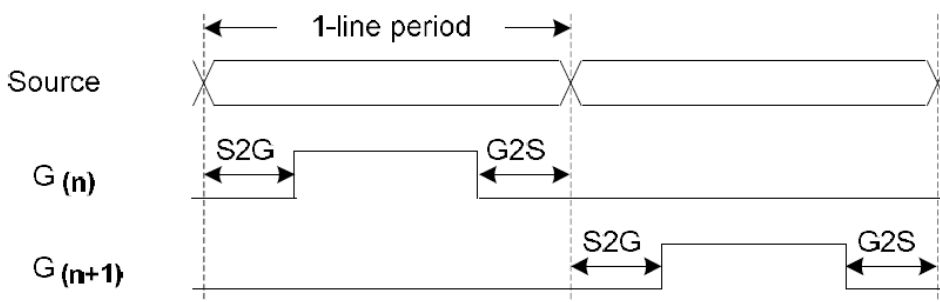

**(26) Resolution Setting (TRES) (R61H)**

Action	W/R	C/D	D7	D6	D5	D4	D3	D2	D1	D0
Set Display Resolution	0	0	0	1	1	0	0	0	0	1
	0	1	-	-	-	-	-	-	-	HRES[8]
	0	1	HRES[7:3]					0	0	0
	0	1	-	-	-	-	-	-	-	VRES[8]
	0	0	VRES[7:0]							

This command defines the alternative resolution and this setting is of higher priority than the RES[1:0] in R00H (PSR).

HRES[8:3]: Horizontal Display Resolution

VRES[8:0]: Vertical Display Resolution

Active Channel Calculation:

GD: First active gate = G0 (Fixed); LAST active gate = VRES[8:0]-1

SD: First active source = S0 (Fixed); LAST active source = HRES[8:3]\*8-1

**(27) GSST Setting (GSST) (R65H)**

Action	W/R	C/D	D7	D6	D5	D4	D3	D2	D1	D0
Gate/Source Start Setting	0	0	0	1	1	0	0	1	0	1
	0	1	-	-	-	-	-	-	-	HST8
	0	1	HST[7:3]					0	0	0
	0	1	-	-	-	-	-	-	-	VST[8]
	0	1	VST[7:0]							

This command defines the First Active Gate and First Active Source of active channels.

HST[8:3]: First active source. (Default: S0)

VST[8:0]: First active gate. (Default: G0)

**(28) Get Status (FLG) (R71H)**

Action	W/R	C/D	D7	D6	D5	D4	D3	D2	D1	D0
Read Flags	0	0	0	1	1	1	0	0	0	1
	1	1	-	PTL_flag	I <sup>2</sup> C_ERR	I <sup>2</sup> C_BUSY	data_flag	PON	POF	BUSY

This command reads the IC status.

PTL\_FLAG: Partial display status (high: partial mode)

I<sup>2</sup>C\_ERR: I<sup>2</sup>C master error status

I<sup>2</sup>C\_BUSY: I<sup>2</sup>C master BUSY status (low active)

data\_flag: Driver has already received all the one frame data

PON: Power ON status

POF: Power OFF status

BUSY: Driver busy status (low active)



(29) Auto Measure VCOM (AMV) (R80H)

Action	W/R	C/D	D7	D6	D5	D4	D3	D2	D1	D0
Automatically Measure VCOM	0	0	1	0	0	0	0	0	0	0
	0	1	-	-	AMVT[1:0]		XON	AMVS	AMV	AMVE

This command reads the IC status.

AMVT[1:0]: Auto Measure VCOM Time  
00b: 3s           01b: 5s (Default)  
10b: 8s           11b:10s

XON: All Gate ON of AMV

0: Gate normally scans during Auto Measure VCOM period. (Default)  
1: All Gate ON during Auto Measure VCOM period.

AMVS: Source Output of AMV

0: Source output 0V during Auto Measure VCOM period. (Default)  
1: Source output VDHR during Auto Measure VCOM period.

AMV: Analog Signal

0: Get VCOM value with the VV command (R18h) (Default)  
1: Get VCOM value in analog signal. (external analog to digital converter)

AMVE: Auto Measure VCOM Enable (Disable)

0: No effect  
1: Trigger Auto VCOM sensing

(30) VCOM Value (VV) (R81H)

Action	W/R	C/D	D7	D6	D5	D4	D3	D2	D1	D0
Automatically Measure VCOM	0	0	1	0	0	0	0	0	0	1
	1	1	-	-	VV[5:0]					

This command gets the VCOM value.

VV[5:0]: VCOM Value Output

VV[5:0]	VCOM Value
00 0000b	-0.10 V
00 0001b	-0.15 V
00 0010b	-0.20 V
:	:
11 1010b	-3.00 V

(31) VCOM-DC Setting (VDCS) (R82H)

Action	W/R	C/D	D7	D6	D5	D4	D3	D2	D1	D0
Set VCM_DC	0	0	1	0	0	0	0	0	1	0
	0	1	-	-	VDCS[5:0]					

This command set VCOM\_DC value.

**VDCS[5:0]: VCOM-DC Setting**

VDCS[5:0]	VCOM Value
00 0000b	-0.10 V (Default)
00 0001b	-0.15 V
00 0010b	-0.20 V
:	:
11 1010b	-3.00 V

**(32) Partial Window (PTL) (R90H)**

Action	W/R	C/D	D7	D6	D5	D4	D3	D2	D1	D0
Set Partial Window	0	0	1	0	0	1	0	0	0	0
	0	1	-	-	-	-	-	-	-	HRST[8]
	0	1	HRST[7:3]					0	0	0
	0	1	-	-	-	-	-	-	-	HRED[8]
	0	1	HRED[7:3]					1	1	1
	0	1	-	-	-	-	-	-	-	VRST[8]
	0	1	VRST[7:0]							
	0	1	-	-	-	-	-	-	-	VRED[8]
	0	1	VRED[7:0]							
	0	1	-	-	-	-	-	-	-	PT_SCAN

This command sets partial window.

HRST[8:3]: Horizontal start channel bank. (value 00h~31h)

HRED[7:3]: Horizontal end channel bank. (value 00h~31h). HRED must be greater than HRST.

VRST[8:0]: Vertical start line. (value 000h~12Bh)

VRED[8:0]: Vertical end line. (value 000h~12Bh). VRED must be greater than VRST.

PT\_SCAN: 0: Gates scan only inside of the partial window.

1: Gates scan both inside and outside of the partial window. (default)

**(33) Partial In (PTIN) (R91H)**

Action	W/R	C/D	D7	D6	D5	D4	D3	D2	D1	D0
Partial In	0	0	1	0	0	1	0	0	0	1

This command makes the display enter partial mode.

**(34) Partial Out (PTOUT) (R92H)**

Action	W/R	C/D	D7	D6	D5	D4	D3	D2	D1	D0
Partial Out	0	0	1	0	0	1	0	0	1	0

This command makes the display exit partial mode and enter normal mode.

**(35) Program Mode (PGM) (RA0H)**

Action	W/R	C/D	D7	D6	D5	D4	D3	D2	D1	D0
Enter Program Mode	0	0	1	0	1	0	0	0	0	0
	0	1	1	0	1	0	0	1	0	1

After this command is issued, the chip will enter the program mode.

The mode would return to standby by hardware reset.

The only one parameter is a check code, the command would be executed if check code = 0xA5.

**(36) Active Program Mode (APG) (RA1H)**

Action	W/R	C/D	D7	D6	D5	D4	D3	D2	D1	D0
Active Program OTP	0	0	1	0	1	0	0	0	0	1

After this command is transmitted, the programming state machine will be activated.  
 The BUSY flag will fall to 0 until the programming is completed.

**(37) Read OTP Data (ROTP) (RA2H)**

Action	W/R	C/D	D7	D6	D5	D4	D3	D2	D1	D0
Read OTP Data for Check	0	0	1	0	1	0	0	0	1	0
	1	1	Dummy							
	1	1	The data of address 0x000 in the OTP							
	1	1	The data of address 0x001 in the OTP							
	1	1	..							
	1	1	The data of address (n-1) in the OTP							
	1	1	The data of address (n) in the OTP							

This command is used for reading the content of OTP for checking the data of programming.

The value of (n) is dependent on the amount of programmed data, the max address = 0xFFF.

The sequence of programming OTP:

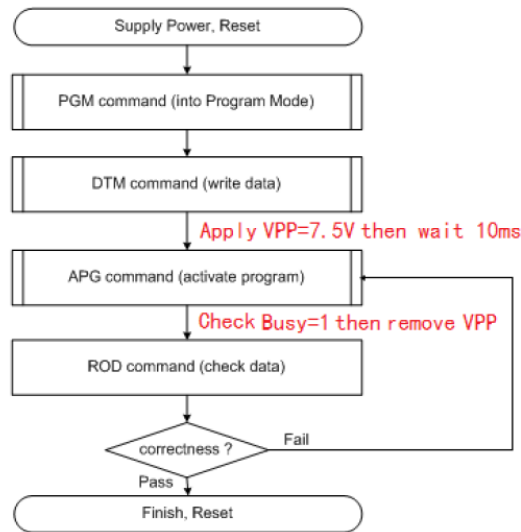

**(38) Power Saving (PWS) (RE3H)**

Action	W/R	C/D	D7	D6	D5	D4	D3	D2	D1	D0
Power Saving for VCOM & Source	0	0	1	1	1	0	0	0	1	1
	0	1	VCOM_W[3:0]				SD_W[3:0]			

This command is set for saving power during fresh period. If the output voltage of VCOM / Source is from negative to positive or from positive to negative, the power saving mechanism will be activated. The active period width is defined by the following two parameters.

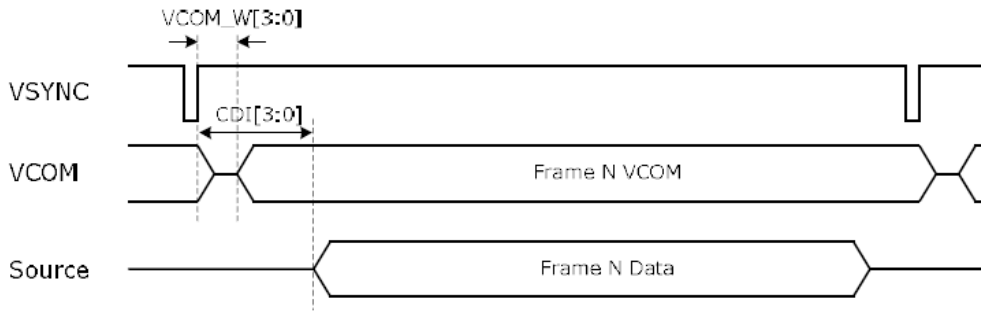

VCOM\_W[3:0]: VCOM power saving width (unit = line period)



SD\_W[3:0]: Source power saving width (unit = 660nS)

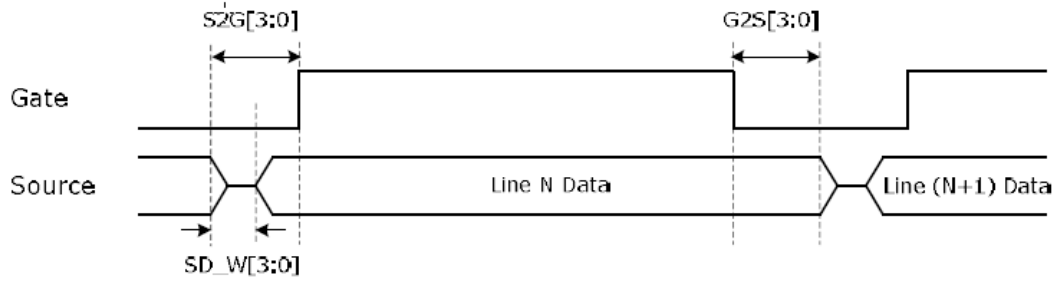

## 7. Electrical Characteristics

### 7.1. Absolute Maximum Rating

Parameter	Symbol	Rating	Unit
Logic Supply Voltage	$V_{CI}$	-0.3 to +6.0	V
Logic Input Voltage	$V_{IN}$	-0.3 to $V_{CI} + 2.4$	V
Operating Temp. range	$T_{OPR}$	0 to +50	°C
Storage Temp. range	$T_{STG}$	-25 to +70	°C
Humidity Range	RH	40~70	%

**IMPORTANT:** Use a UV protective film when operating the module in direct sunlight.

### 7.2. Panel DC Characteristics

The following specifications apply for:  $V_{SS} = 0V$ ,  $V_{CI} = 3.3V$ ,  $T_A = 25^\circ C$

Parameter	Symbol	Conditions	Min	Typ	Max	Unit
Ground	$V_{SS}$	-	-	0	-	V
Supply Voltage	$V_{CI}$	-	2.3	3.3	3.6	V
High Level Input Voltage	$V_{IH}$	Digital Input Pins	$0.7V_{CI}$	-	$V_{CI}$	V
Low Level Input Voltage	$V_{IL}$	Digital Input Pins	0	-	$0.3V_{CI}$	V
High Level Output Voltage	$V_{OH}$	Digital Input Pins, $I_{OH} = 400\mu A$	$V_{CI} - 0.4$	-	-	V
Low Level Output Voltage	$V_{OL}$	Digital Input Pins, $I_{OL} = -400\mu A$	0	-	0.4	V
Image Update Current	$I_{UPDATE}$	-	-	8	10	mA
Standby Panel Current	$I_{STANDBY}$	-	-	-	5	$\mu A$
Power Panel (Update)	$P_{UPDATE}$	-	-	26.4	40	mW
Standby Power Panel	$P_{STBY}$	-	-	-	0.0165	mW
Operating Temperature	-	-	0	-	50	°C
Storage Temperature	-	-	-25	-	70	°C
Image update Time at 25°C	-	-	-	6	8	sec
Deep sleep mode current	$I_{VCI}$	DC/DC off No clock No input load Ram data not retain	-	2	5	$\mu A$
Sleep mode current	$I_{VCI}$	DC/DC off No clock No input load Ram data retain	-	35	50	$\mu A$

The typical power consumption is measured with the following pattern transition: from horizontal 2 gray scale pattern to vertical 2 gray scale pattern, shown below.

Note: The standby power is the consumed power when the panel controller is in standby mode. The listed electrical/optical characteristics are only guaranteed under the controller & waveform provided by Crystalfontz.  $V_{COM}$  is recommended to be set in the range of assigned value  $\pm 0.1V$ .

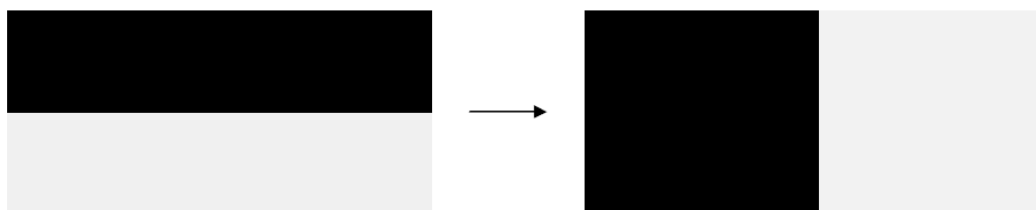



### 7.3. Panel AC Characteristics

#### 7.3.1. Oscillator Frequency

The following specifications apply for:  $V_{SS} = 0V$ ,  $V_{CI} = 3.3V$ ,  $T_A = 25^\circ C$

Parameter	Symbol	Conditions	Min	Typ	Max	Unit
Internal Oscillator Frequency	$F_{osc}$	$V_{CI}=2.3$ to $3.6V$	-	1.625	-	MHz

#### 7.3.2. MCU Interface Selection

In this module, there are 4-wire SPI and 3-wire SPI that can communicate with MCU. The MCU interface mode can be set by hardware selection on BS1 pins. When it is "Low", 4-wire SPI is selected. When it is "High", 3-wire SPI (9 bits SPI) is selected.

Pin Name	Data/Command Interface		Control Signal		
Bus Interface	D1	D0	CS#	D/C#	RES#
SPI4	SDIN	SCLK	CS#	D/C#	RES#
SPI3	SDIN	SCLK	CS#	LOW	RES#

Table 7-1: MCU Interface Assignment Under Different Bus Interface Mode

#### 7.3.3. MCU Serial Interface (4-Wire SPI)

The 4-wire SPI consists of serial clock SCLK, serial data SDIN, D/C#, CS#. In SPI mode, D0 acts as SCLK, D1 acts as SDIN.

Function	CS#	D/C#	SCLK
Write Command	L	L	↑
Write Data	L	H	↑

Table 7-2: Control Pins of 4-Wire Serial Peripheral Interface

Note: ↑stands for rising edge of signal

SDIN is shifted into an 8-bit shift register in the order of D7, D6...D0. The data byte in the shift register is written to the Graphic Display Data RAM (RAM) or command register in the same clock. Under serial mode, only write operations are allowed.

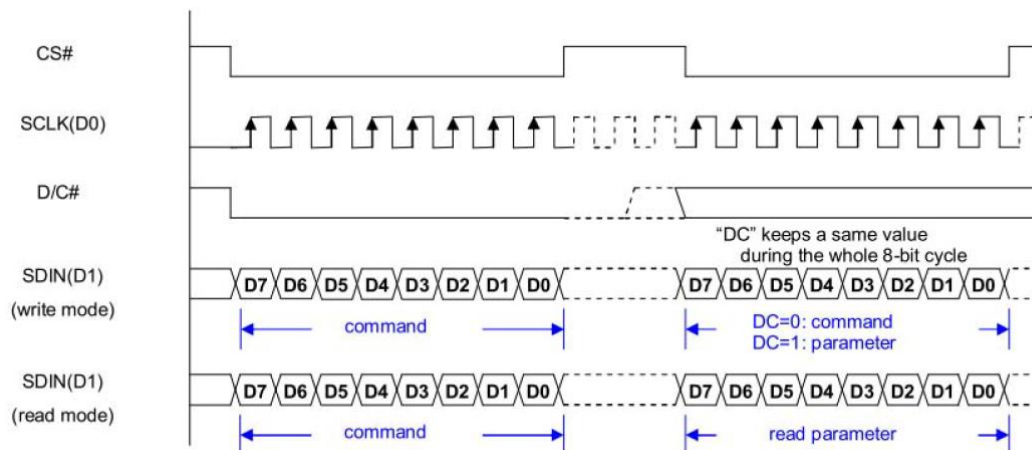

Figure 7-1: Write Procedure in 4-Wire Serial Peripheral Interface Mode

### 7.3.4. MCU Serial Interface (3-Wire SPI)

The 3-wire serial interface consists of serial clock SCLK, serial data in SDIN and CS#. In 3-wire SPI mode, D0 acts as SCLK, D1 acts as SDIN. The pin D/C# can be connected to an external ground.

The operation is similar to 4-wire serial interface while D/C# pin is not used. There are altogether 9-bits that will be shifted into the shift register on every ninth clock in sequence: D/C# bit, D7 to D0 bit. The D/C# bit (first bit of the sequential data) will determine the following data byte in shift register is written to the Display Data RAM (D/C# bit = 1) or the command register (D/C# bit = 0). Under serial mode, only write operations are allowed.

Function	CS#	D/C#	SCLK
Write Command	LOW	Tie LOW	↑
Write Data	LOW	Tie LOW	↑

Table 7-3: Control Pins of 3-Wire Serial Peripheral Interface

Note: ↑stands for rising edge of signal

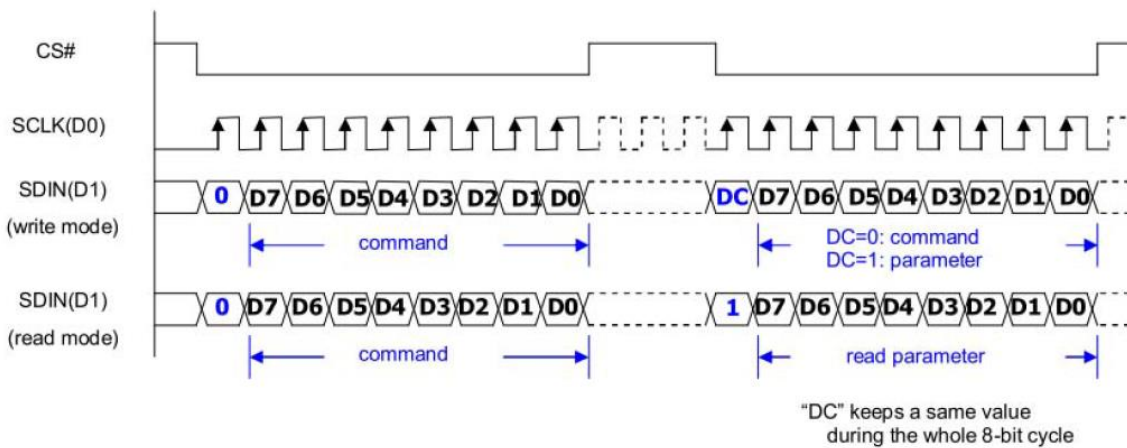
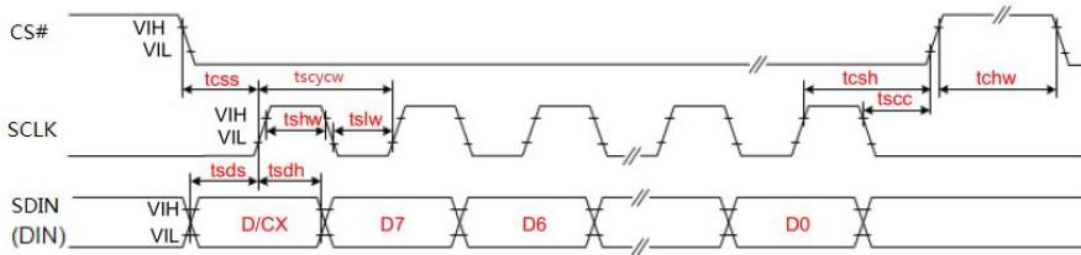
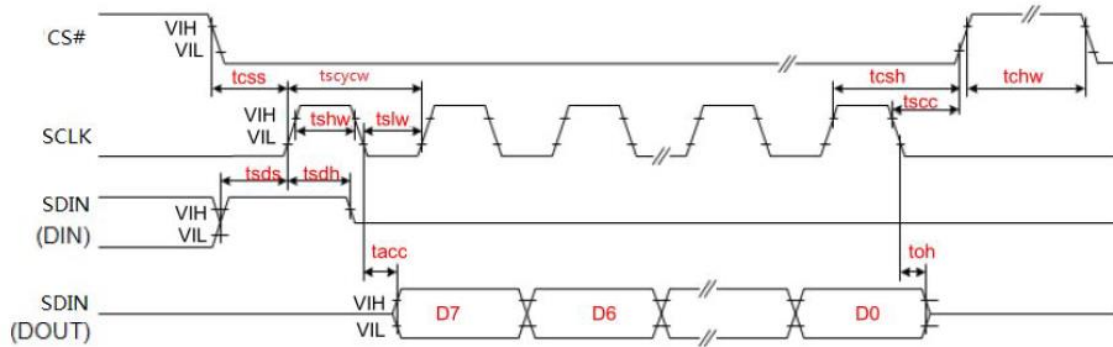

Figure 7-2: Write Procedure in 3-Wire Serial Peripheral Interface Mode

### 7.3.5. Timing Characteristics of Serial Interface



3-wire Serial Interface – Write



3-wire Serial Interface – Read

Symbol	Signal	Parameter	Min	Typ	Max	Unit
$t_{css}$	CS#	Chip Select Setup Time	60	-	-	ns
$t_{csh}$		Chip Select Hold Time	65	-	-	ns
$t_{scc}$		Chip Select Setup Time	20	-	-	ns
$t_{chw}$		Chip Select Setup Time	40	-	-	ns
$t_{scycw}$	SCLK	Serial Clock Cycle (Write)	100	-	-	ns
$t_{shw}$		SCLK "H" Pulse Width (Write)	35	-	-	ns
$t_{slw}$		SCLK "L" Pulse Width (Write)	35	-	-	ns
$t_{scycr}$		Serial Clock Cycle (Read)	150	-	-	ns
$t_{shr}$		SCLK "H" Pulse Width (Read)	60	-	-	ns
$t_{slr}$		SCLK "L" Pulse Width (Read)	60	-	-	ns
$t_{sds}$	SDIN (DIN) (DOUT)	Data Setup Time	30	-	-	ns
$t_{sdh}$		Data Hold Time	30	-	-	ns
$t_{acc}$		Access Time	-	-	10	ns
$t_{oh}$		Output Disable Time	15	-	-	ns



### 7.4. Power Consumption

Parameter	Symbol	Conditions	TYP	Max	Unit	Remark
Panel Power Consumption During Update	-	25°C	26.4	40	mW	-
Power Consumption in Standby Mode	-	25°C	-	0.0165	mW	-

### 7.5. Reference Circuit

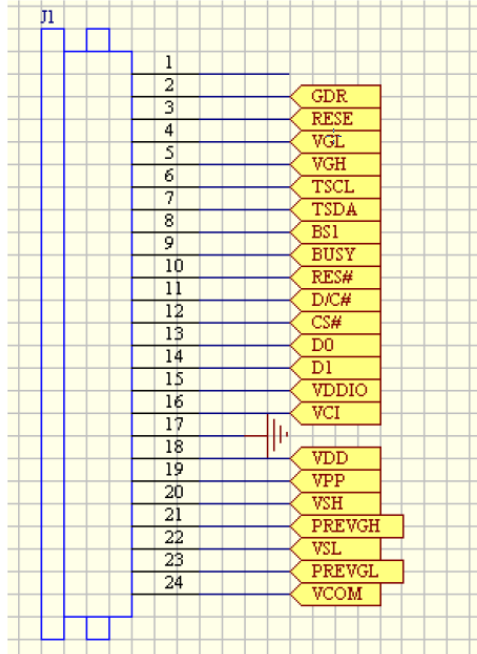

Figure 7-5 (1)

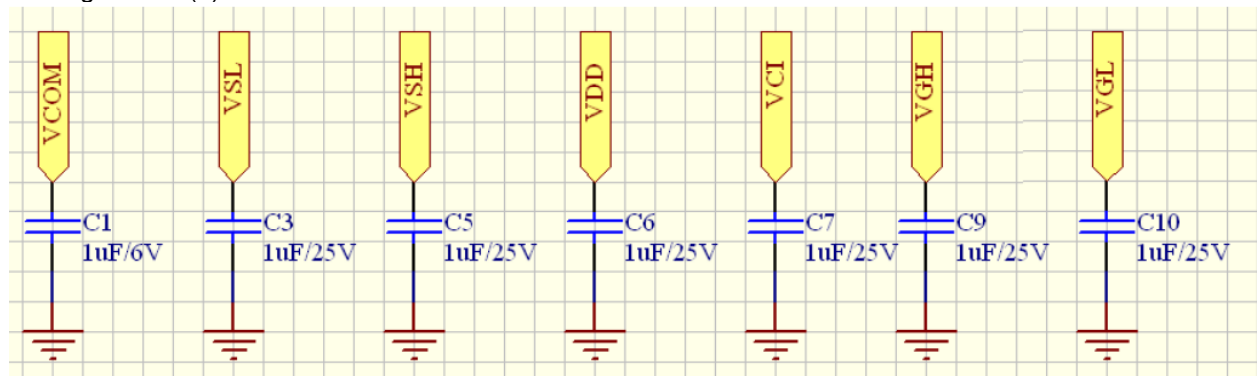



Figure 7-5 (2)

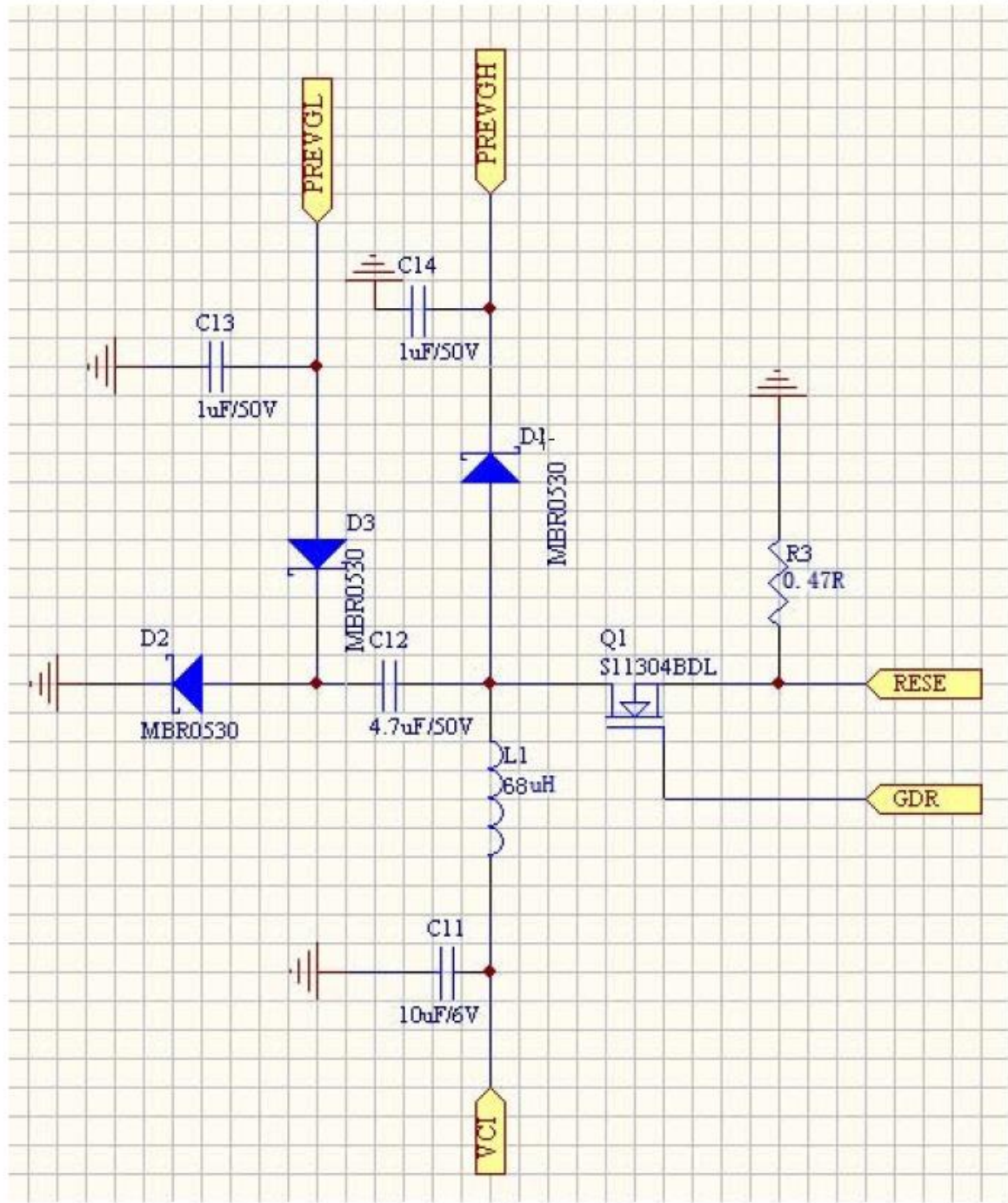

Figure 7-5 (3)

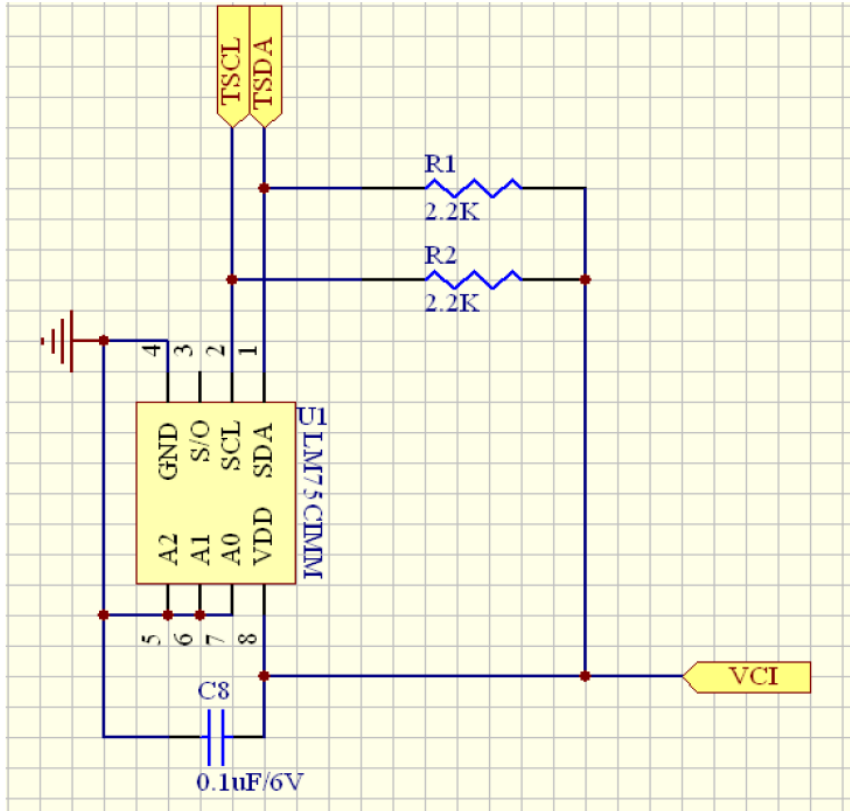

Figure 7-5 (4)



## 8. Typical Operating Sequence

### 8.1. Normal Operation Flow

#### 8.1.1. BWR Mode & LUT from Register

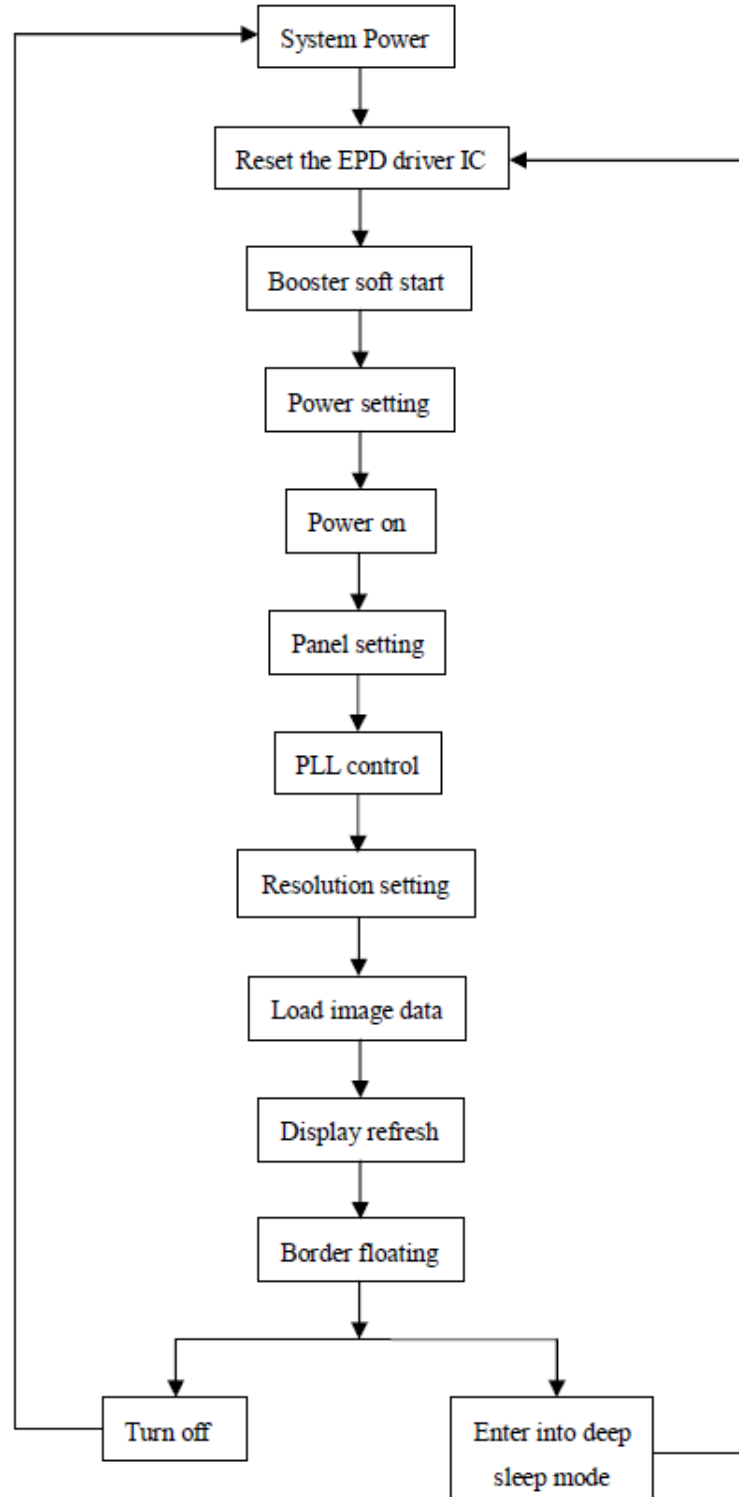



### 8.1.2. BWR Mode & LUT from OTP

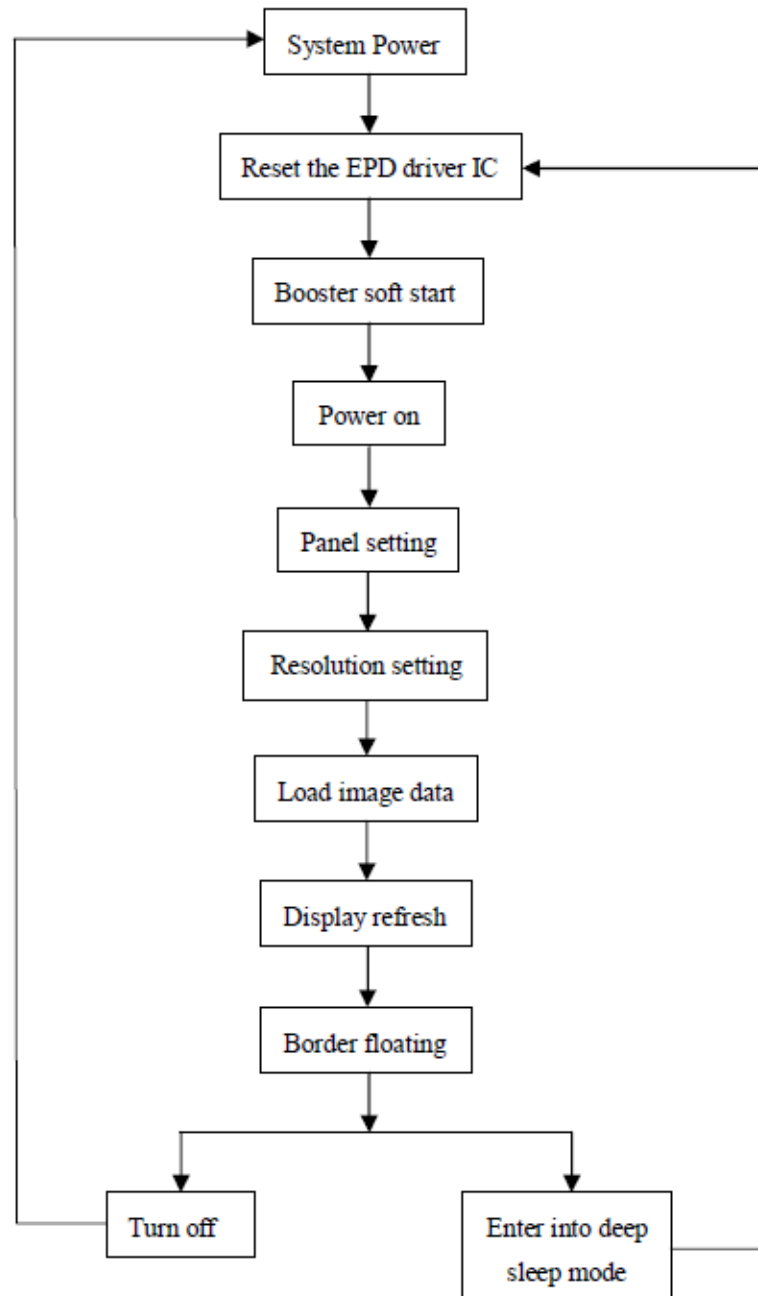





## 8.2. Reference Program Code

### 8.2.1. BWR Mode & LUT from Register

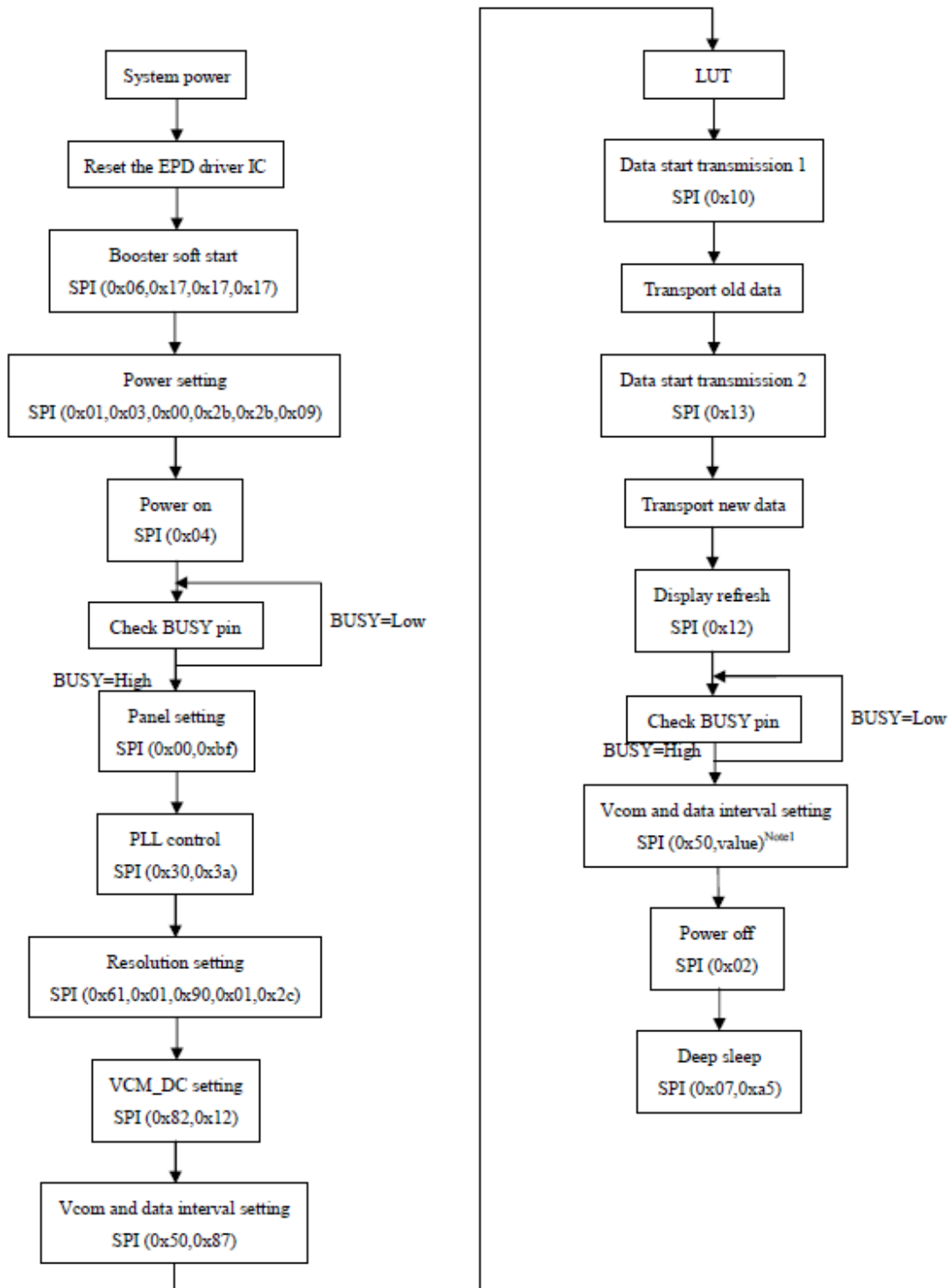

**NOTE:** Set border to floating.



### 8.2.2. BWR Mode & LUT from OTP

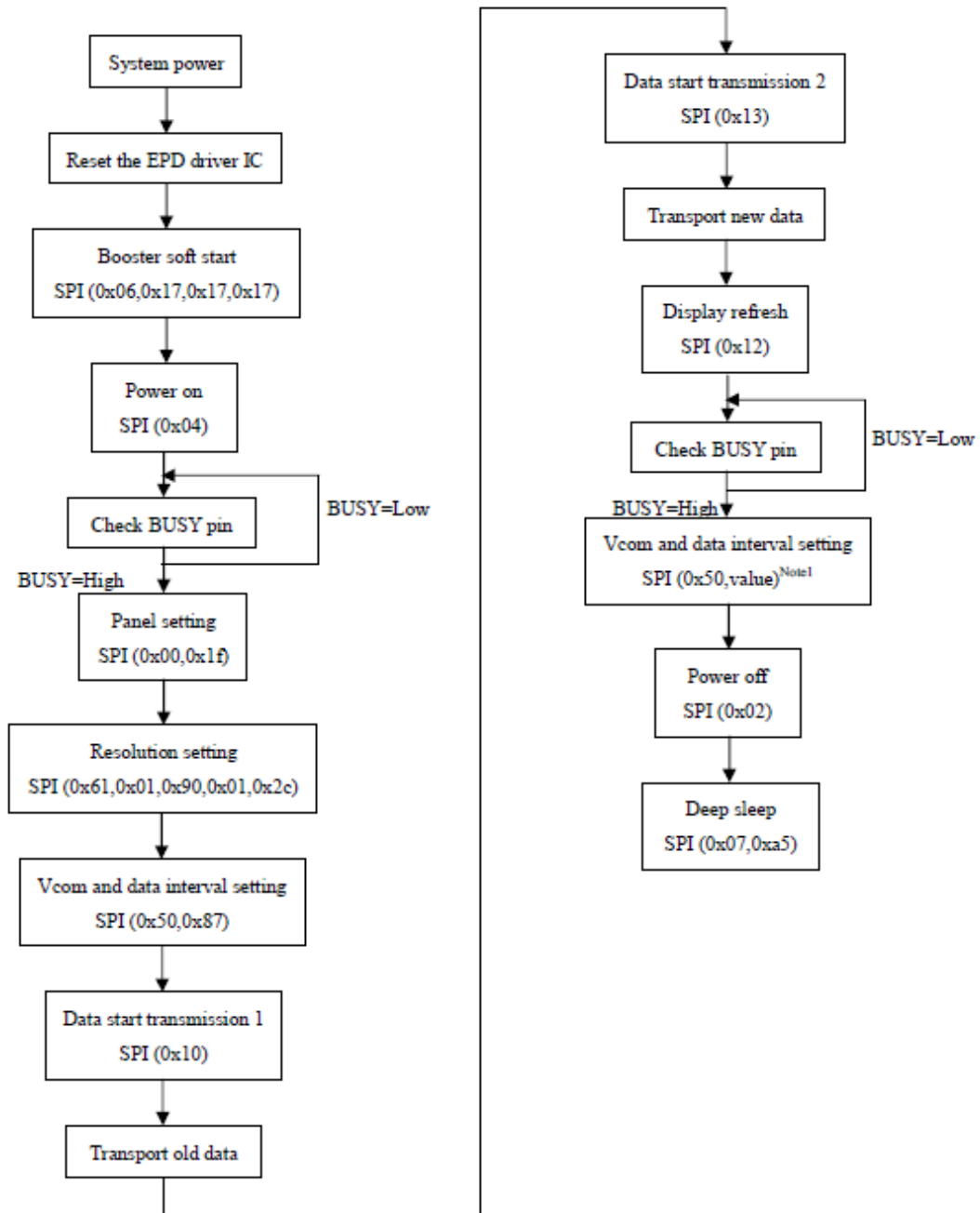

**NOTE:** Set border to floating.



## 9. Optical Characteristics

### 9.1. Specifications

Measurements are made with the illumination under an angle of 45 degrees, the detection is perpendicular unless otherwise specified.

T=25°C

Symbol	Parameter	Conditions	Min	Type	Max	Unit	Note
R	Reflectance	White	30	35	-	%	Note 9-1
Gn	2Gray Level	-	-	$DS + (WS-DS) \times n (m-1)$	-	L*	-
CR	Contrast Ratio	Indoor	8		-	-	-
Lifetime	-	0°C~50°C	-	1,000,000 times or 5 years	-	-	Note 9-2

WS: White State, DS: Dark State

Gray State from Dark to White: DS, WS

m: 2

Note (9-1): Luminance meter: Eye – One Pro Spectrophotometer

Note (9-2): Panel life is not guaranteed when worked in temperatures below 0 degrees or above 50 degrees. Each update interval time should be at a minimum of 180 seconds.

### 9.2. Definition of Contrast Ratio

The contrast ratio (CR) is the ratio between the reflectance in a full white area (R1) and the reflectance in a dark area (Rd) ():

R1: White Reflectance      Rd: Dark Reflectance

$CR = R1/Rd$

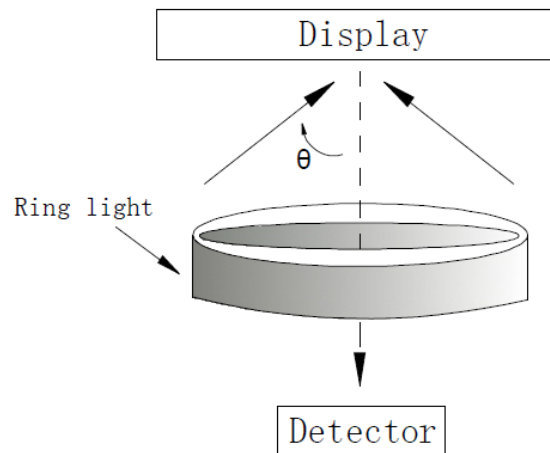



### 9.3. Reflection Ratio

The reflection ratio is expressed as:

$$R = \text{Reflectance Factor}_{\text{white board}} \times (L_{\text{CENTER}} / L_{\text{WHITE BOARD}})$$

$L_{\text{CENTER}}$  is the luminance measured at center in a white area ( $R=G=B=1$ ).  $L_{\text{WHITE BOARD}}$  is the luminance of a standard white board. Both are measured with equivalent illumination source. The viewing angle shall be no more than 2 degrees.

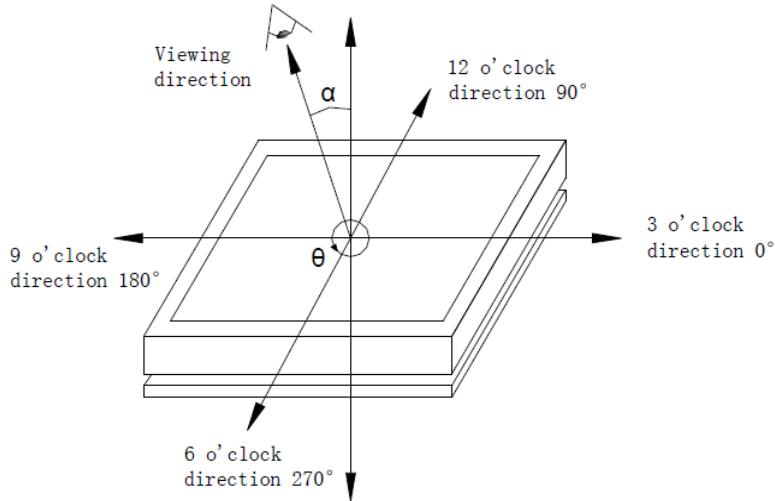

### 9.4. Bi-Stability

The Bi-Stability standard is as follows:

Bi-Stability	Result		
		AVG	MAX
24-Hour Luminance Drift	White state $\Delta L^*$	-	3
	Black state $\Delta L^*$	-	3

## 10. Mechanical Drawing

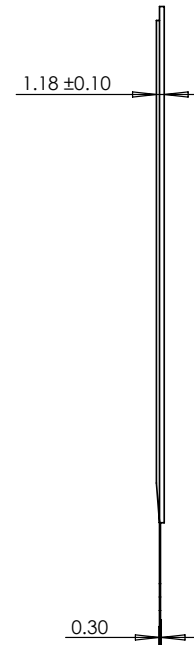
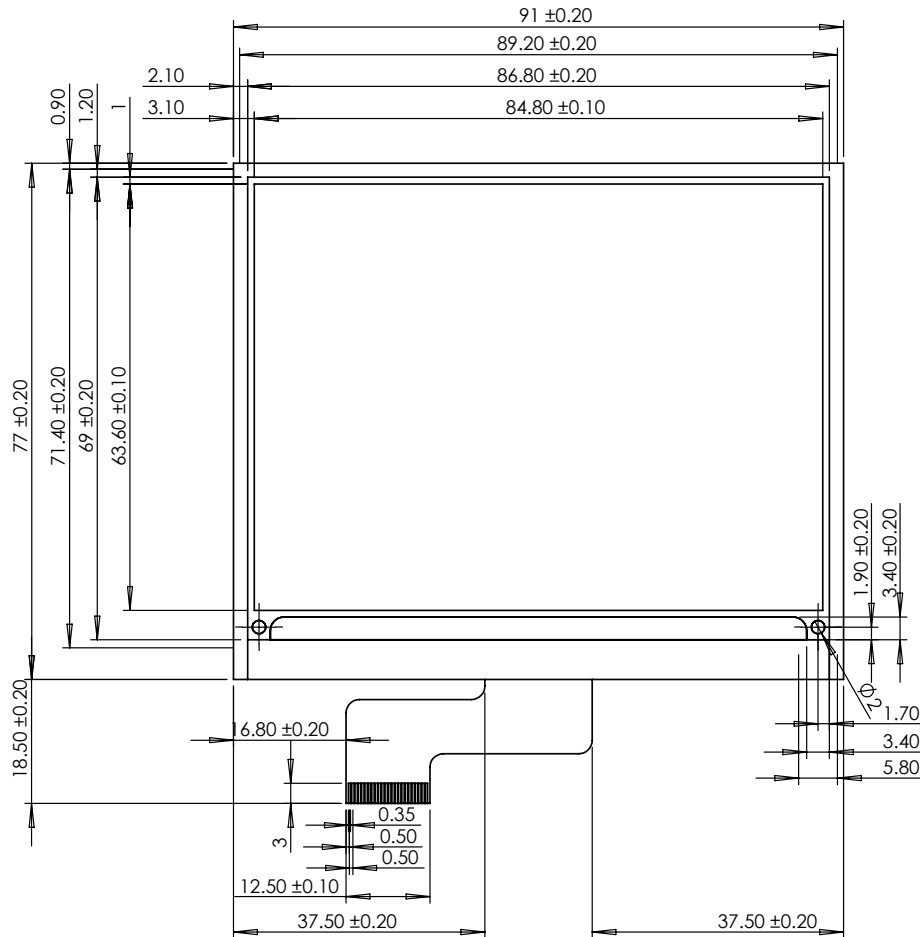

Pin	Function
1	NC
2	GDR
3	RESE
4	VGL
5	VGH
6	TSCL
7	TSDA
8	BSI
9	BUSY
10	RES#
11	D/C#
12	CS#
13	SCI
14	SDA
15	VDDIO
16	VCI
17	VSS
18	VDD
19	VPP
20	VSH
21	PREVGH
22	VSL
23	PREVGL
24	VCOM

Units: millimeters  
Tolerance: ±0.15

# 11. ePaper Breakout Board Schematic



REV	ENGINEER	DATE	REMARKS
0v0	BAC	2018-04-04	Initial Creation
0v1	BAC	2018-05-17	Ind val, C12 val, JP_0P47 open, CN FPC
-	-	-	-
-	-	-	-
-	-	-	-

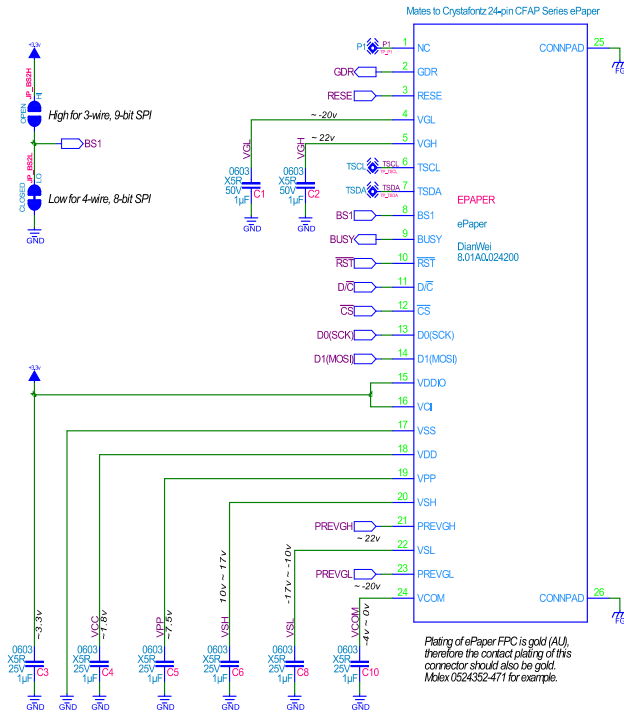
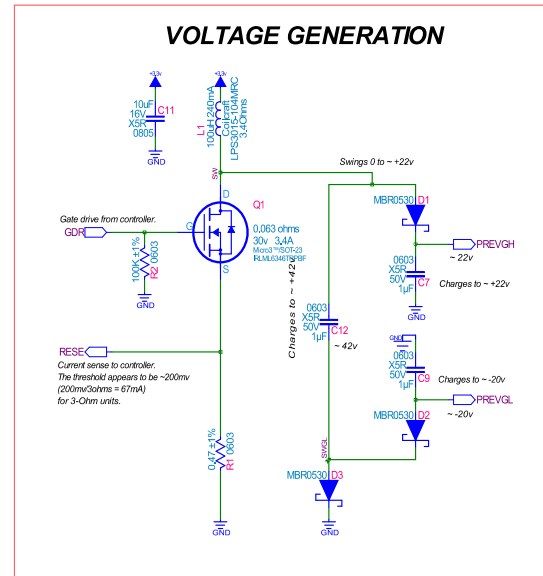
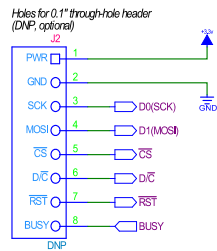
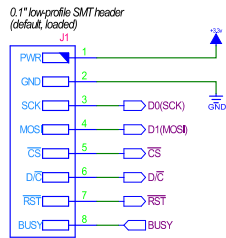

 **Crystalfontz America, Inc.** Copyright ©2018 Crystalfontz America, Inc.

CFA-10084: ePaper Adapter Board 24-pin (0.47 ohm)

Page 1/1: Schematic

PRODUCT NAME:	PRODUCT REVISION/PCB NUMBER:	PCB REVISION:
CFA-10084	0v1 PCB-10084	0v1