



OLED DISPLAY MODULE DATASHEET



Datasheet Release Date 2019-10-21 for
CFAL12864G-024W

Revision 1v1

CrystalFontz America, Inc.

12412 East Saltese Avenue
Spokane Valley, WA 99216-0357
Phone: 888-206-9720
Fax: 509-892-1203

Email: support@crystalfontz.com

URL: www.crystalfontz.com

1. General Information

Datasheet Revision History

Datasheet Release: 2019-10-21
Datasheet for the CFAL12864G-024W OLED graphic display module.

Product Change Notifications

You can check for or subscribe to [Part Change Notices](#) for this display module on our website.

Variations

Slight variations between lots are normal (e.g., contrast, color, or intensity).

Volatility

This display module has volatile memory.

Disclaimer

Certain applications using CrystalFontz America, Inc. products may involve potential risks of death, personal injury, or severe property or environmental damage (“Critical Applications”). CRYSTALFONTZ AMERICA, INC. PRODUCTS ARE NOT DESIGNED, INTENDED, AUTHORIZED, OR WARRANTED TO BE SUITABLE FOR USE IN LIFE-SUPPORT APPLICATIONS, DEVICES OR SYSTEMS OR OTHER CRITICAL APPLICATIONS. Inclusion of CrystalFontz America, Inc. products in such applications is understood to be fully at the risk of the customer. In order to minimize risks associated with customer applications, adequate design and operating safeguards should be provided by the customer to minimize inherent or procedural hazard. Please contact us if you have any questions concerning potential risk applications.

CrystalFontz America, Inc. assumes no liability for applications assistance, customer product design, software performance, or infringements of patents or services described herein. Nor does CrystalFontz America, Inc. warrant or represent that any license, either express or implied, is granted under any patent right, copyright, or other intellectual property right of CrystalFontz America, Inc. covering or relating to any combination, machine, or process in which our products or services might be or are used.

All specifications in datasheets on our website are, to the best of our knowledge, accurate but not guaranteed. Corrections to specifications are made as any inaccuracies are discovered.

Company and product names mentioned in this publication are trademarks or registered trademarks of their respective owners.

Copyright © 2019 by CrystalFontz America, Inc., 12412 East Saltese Avenue, Spokane Valley, WA 99216 U.S.A.



2. General Description

This is a chip-on-glass OLED monochrome graphic display module with a ZIF FPC and has a built in SSD1309IC. This display module is lightweight, ultra-thin with low power consumption. This display is white; however, it is also available in yellow.

3. Features

- 128*64 Dot Matrix
- Built-in Controller SSD1309ZC
- +3V Power Supply
- 1/64 Duty
- Interface: 6800, 8080, SPI, I²C
- Polarizer

4. Mechanical Data

Item	Standard View	Unit
Module Dimension	60.5 x 37.0 x 2.15	mm
Viewing Area	57.01 x 28.91	mm
Active Area	55.01 x 27.49	mm
Pixel Pitch	0.43 x 0.43	mm
Pixel Size	0.40 x 0.40	mm
Weight	9.2	g

5. Mechanical Drawing

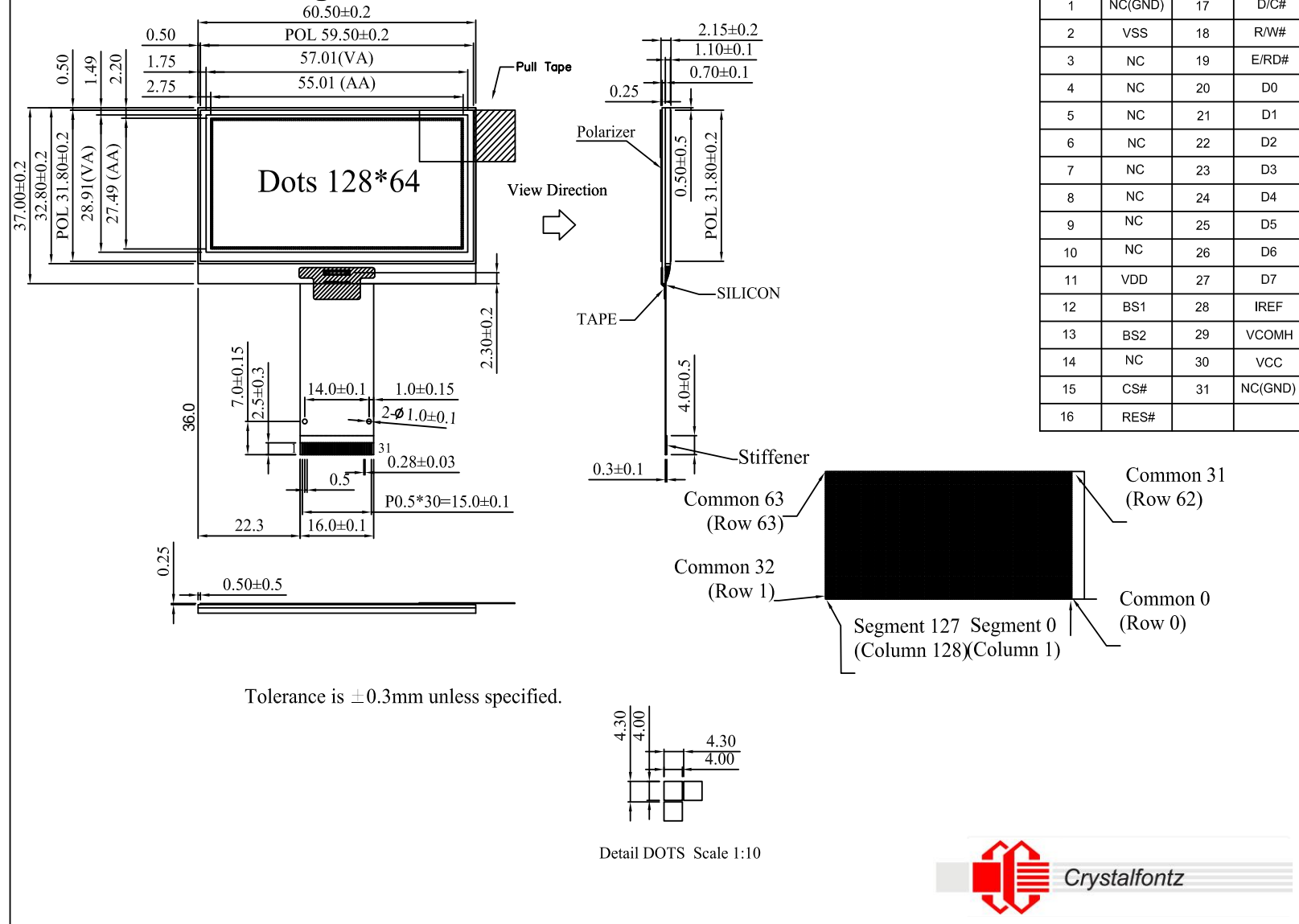

6. Interface PIN Function

PIN No.	Symbol	Function															
1	NC	No connection, ground															
2	V _{SS}	Ground															
3-10	NC	No connection															
11	V _{DD}	Power supply pin for core logic operation															
12	BS1	<p>MCU bus interface selection pins. Select appropriate logic setting as described in the following table. BS2, BS1 and BS0 are pin select:</p> <table border="1"> <thead> <tr> <th></th> <th>BS1</th> <th>BS2</th> </tr> </thead> <tbody> <tr> <td>I²C</td> <td>1</td> <td>0</td> </tr> <tr> <td>4-wire serial</td> <td>0</td> <td>0</td> </tr> <tr> <td>8-bit 6800 Parallel</td> <td>0</td> <td>1</td> </tr> <tr> <td>8-bit 8080 Parallel</td> <td>1</td> <td>1</td> </tr> </tbody> </table>		BS1	BS2	I ² C	1	0	4-wire serial	0	0	8-bit 6800 Parallel	0	1	8-bit 8080 Parallel	1	1
	BS1	BS2															
I ² C	1	0															
4-wire serial	0	0															
8-bit 6800 Parallel	0	1															
8-bit 8080 Parallel	1	1															
13	BS2	<p>Note: 0 is connected to V_{SS} 1 is connected to V_{DD}</p>															
14	NC	No connection															
15	CS#	Chip select input connecting to the MCU. The chip is enabled for MCU communication only when CS# is pulled LOW (active LOW).															
16	RES#	Reset signal input. When RES# is pulled LOW, initialization of the chip is executed. Keep this pin pulled HIGH during normal operation.															
17	D/C#	<p>Data/Command control pin for connecting to the MCU. When the pin is pulled HIGH, the data at D[7:0] will be interpreted as data. When the pin is pulled LOW, the data at D[7:0] will be transferred to a command register. In I²C mode, this pin acts as SA0 for slave address selection. When 3-wire serial interface is selected, this pin must be connected to V_{SS}.</p>															
18	R/W# WR#	<p>Read / write control input pin connecting to the MCU interface. When 6800 interface mode is selected, this pin is the Read/Write (R/W#) selection input. Read mode will be carried out when this pin is pulled HIGH and write mode when LOW. When 8080 interface mode is selected, this pin will be the Write (WR#) input. Data write operation is initiated when this pin is pulled LOW and the chip is selected. When serial or I²C interface mode is selected, this pin must be connected to V_{SS}.</p>															
19	E RD#	<p>MCU interface input. When 6800 interface mode is selected, this pin will be used as the Enable (E) signal. Read/write operation is initiated when this pin is pulled HIGH and the chip is selected. When 8080 interface mode is selected, this pin receives the Read (RD#) signal. Read operation is initiated when this pin is pulled LOW and the chip is selected. When serial or I²C interface modes is selected, this pin must be connected to V_{SS}.</p>															
20~27	D0~D7 SCLK SDIN	<p>Bi-directional data bus connecting to the MCU data bus. Unused pins are recommended to tie LOW. When serial interface mode is selected, D0 will be the serial</p>															



PIN No.	Symbol	Function
	SDAout SDAin SCL	clock input: SCLK; D1 will be the serial data input: SDIN and D2 should be kept NC. When I²C interface mode is selected, D2, D1 should be tied together and serve as SDAout, SDAin in application and D0 is the serial clock input, SCL.
28	I _{REF}	Segment output current reference pin. I _{REF} is supplied externally, and can be supplied by V _{SS} through a resistor.
29	V _{COMH}	COM signal deselected voltage level. A capacitor should be connected between this pin and V _{SS} .
30	V _{CC}	Power supply for panel driving voltage. This is also the most positive power voltage supply pin.
31	NC(GND)	No connection

7. Schematic

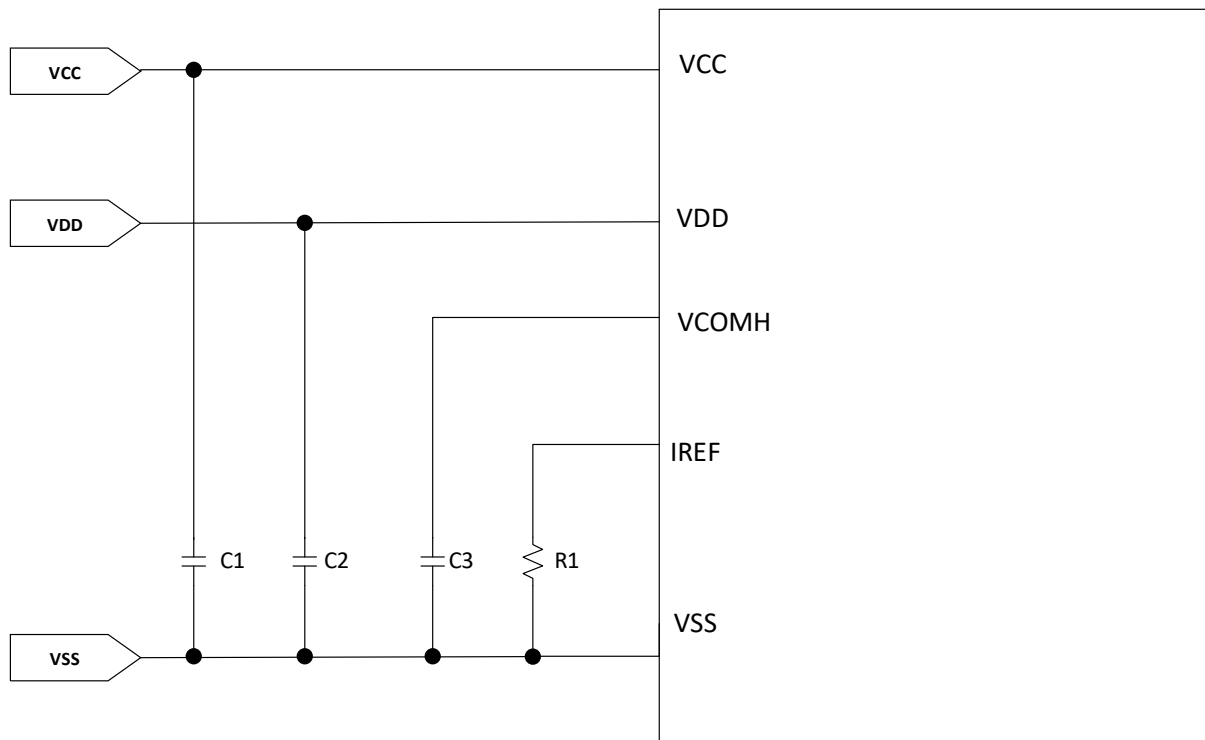

$$V_{IREF} = V_{CC} - 3V = 13V - 3V = 10V$$

$$I_{REF} = 10\mu A$$

$$R1 = V_{IREF} / I_{REF} = 1M\Omega \text{ for } V_{CC} = 13 \text{ volts}$$

$$C1 = C2 = 2.2\mu F$$

$$C4 = 1.0\mu F$$



8. Absolute Maximum Ratings

Parameter	Symbol	Min	Max	Unit	Notes
Supply Voltage for Logic	V _{DD}	-0.3	4	V	(1)(2)(3)
Supply Voltage for Display	V _{CC}	0	15	V	(1)(2)(3)
Operating Temperature	T _{OP}	-40	+80	°C	-
Storage Temperature	T _{STG}	-40	+80	°C	-

Notes:

- (1) All of the above voltages are on the basis of V_{SS} = 0V.
- (2) These are stress ratings only. Extended exposure to the absolute maximum ratings listed above may affect device reliability or cause permanent damage.
- (3) Functional operation should be restricted to the limits in the Electrical Characteristics table below.

9. Electrical Characteristics

Item	Symbol	Condition	Min	Typical	Max	Unit
Supply Voltage for Logic	V _{DD}	-	2.8	3.0	3.3	V
Supply Voltage for Display	V _{CC}	-	12.5	13	13.5	V
High-level Input	V _{IH}	-	0.8 x V _{DD}	-	-	V
Low-level Input	V _{IL}	-	-	-	0.2 x V _{DD}	V
High-level Output	V _{OH}	-	0.9 x V _{DD}	-	-	V
Low-level Output	V _{OL}	-	-	-	0.1 x V _{DD}	V
50% Check Board Operating Current		V _{CC} = 13.0V	15	18	22	mA

10. Optical Characteristics

Item	Symbol	Condition	Min	Typical	Max	Unit
View Angle	(V) θ		160			deg
	(H) ϕ		160			deg
Contrast Ratio	CR	Dark	2000:1		-	-
Response Time	T rise	-		10		μ s
	T fall	-		10		μ s
Display with 50% Check Board Brightness			70	90		cd/m ²
CIE _x (White)	(CIE1931)		0.26	0.28	0.30	
CIE _y (White)	(CIE1931)		0.30	0.32	0.34	

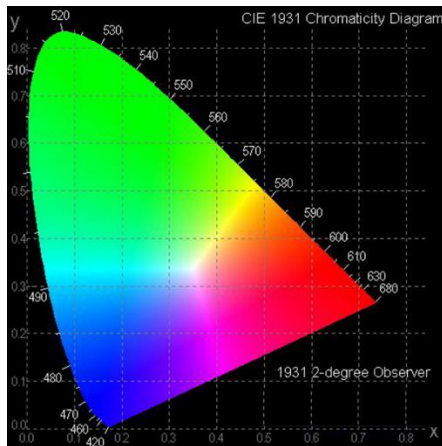

11. OLED Lifetime

Item	Conditions	Min	Typical	Notes
Operating Lifetime	T _a =25°C Initial 50% check board brightness Typical Value	20,000 Hrs	-	(1)(2)(3)

Notes:

- (1) Lifetime is defined as the amount of time when the luminance has decayed to <50% of the initial value.
- (2) This analysis method uses life data obtained under accelerated conditions to extrapolate an estimated Probability Density Function (PDF) for the product under normal use conditions.
- (3) Screen saving mode will extend OLED lifetime.

12. Precautions in Use of OLED Modules

12.1. Modules

- Avoid applying excessive shocks to module or making any alterations or modifications to it.
- Do not make extra holes on the printed circuit board, modify its shape or change the components of OLED display module.
- Do not disassemble the OLED display module.
- Do not operate the OLED display module above the absolute maximum rating.
- Do not drop, bend or twist the OLED display module.
- Soldering: only to the I/O terminals.
- Store in an anti-static electricity container and clean environment.
- It is common to use the "screen saver" to extend the lifetime of the OLED display module.
 - Do not use the fixed information for long periods of time in real application.
 - Do not use fixed information in OLED panel for long periods of time to extend "screen burn" effect time.
- CrystalFontz has the right to change the passive components, including R2 and R3 adjust resistors. (Resistors, capacitors and other passive components will have different appearance and color caused by the different supplier.)
- CrystalFontz have the right to change the PCB Rev. (In order to satisfy the supplying stability, management optimization and the best product performance, etc., under the premise of not affecting the electrical characteristics and external dimensions, CrystalFontz has the right to modify the version.)

12.2. Handling Precautions

- Since the display panel is made of glass, do not apply mechanical impacts such as dropping from a high position.
- If the display panel is accidentally broken, and the internal organic substance leaks out, be careful not to inhale or touch the organic substance.
- If pressure is applied to the display surface or its neighborhood of the OLED display module, the cell structure may be damaged, so be careful not to apply pressure to these sections.
- The polarizer covering the surface of the OLED display module is soft and can be easily scratched. Please be careful when handling the OLED display module.
- Clean the surface of the polarizer covering the OLED display module if it becomes soiled using following adhesion tape.
 - Scotch Mending Tape No. 810 or an equivalent
 - Never breathe the soiled surface or wipe the surface using a cloth containing solvent such as ethyl alcohol, since the surface of the polarizer will become cloudy.
 - The following liquids/solvents may spoil the polarizer:
 - Water
 - Ketone
 - Aromatic Solvents
- Hold the OLED display module very carefully when placing the OLED display module into the system housing.
- Do not apply excessive stress or pressure to the OLED display module. And, do not over bend the film with electrode pattern layouts. These stresses will influence the display performance. Also, be sure to secure the sufficient rigidity for the outer cases.

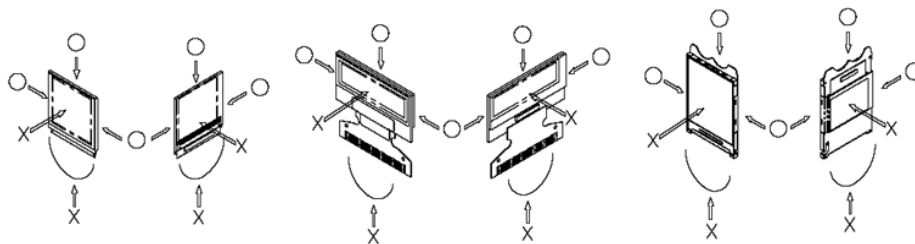

- Do not apply stress to the LSI chips and the surrounding molded sections.
- Do not disassemble or modify the OLED display module.
- Do not apply input signals while the logic power is off.



- Pay sufficient attention to the working environments when handling the OLED display module to prevent occurrence of element breakage accidents by static electricity.
 - Be sure to make human body grounding when handling OLED display modules.
 - Be sure to ground tools to use for assembly such as soldering irons.
 - To suppress generation of static electricity, avoid carrying out assembly work under dry environments.
 - Protective film is being applied to the surface of the display panel of the OLED display module. Be careful since static electricity may be generated when exfoliating the protective film.
- Protection film is being applied to the surface of the display panel and removes the protection film before assembling it. At this time, if the OLED display module has been stored for a long period of time, residue adhesive material of the protection film may remain on the surface of the display panel after the film has been removed. In such a case, remove the residue material by the method discussed above.
- If electric current is applied when the OLED display module is being dewed or when it is placed under high humidity environments, the electrodes may become corroded. If this happens proceed with caution when handling the OLED display module.

12.3. Storage Precautions

- When storing the OLED display modules put them in static electricity preventive bags to avoid exposure to direct sunlight and fluorescent lamps. Also avoid high temperature and high humidity environments and low temperatures (less than 0°C) environments. (We recommend you store these modules in the packaged state when they were shipped from Crystalfontz). Be careful not to let water drops adhere to the packages or bags, and do not let dew gather on them.
- If electric current is applied when water drops are adhering to the surface of the OLED display module the OLED display module may have become dewed. If a dewed OLED display module is placed under high humidity environments it may cause the electrodes to become corroded. If this happens proceed with caution when handling the OLED display module.

12.4. Designing Precautions

- The absolute maximum ratings are the ratings that cannot be exceeded for OLED display module. If these values are exceeded, panel damage may happen.
- To prevent occurrence of malfunctioning by noise pay attention to satisfy the VIL and VIH specifications and, at the same time, to make the signal line cable as short as possible.
- We recommend that you install excess current preventive unit (fuses, etc.) to the power circuit (VDD). (Recommend value: 0.5A)
- Pay sufficient attention to avoid occurrence of mutual noise interference with the neighboring devices.
- As for EMI, take necessary measures on the equipment side.
- When fastening the OLED display module, fasten the external plastic housing section.
- If the power supply to the OLED display module is forcibly shut down, by such errors as taking out the main battery while the OLED display panel is in operation, we cannot guarantee the quality of this OLED display module.
 - Connection (contact) to any other potential than the above may lead to rupture of the IC.

12.5. Disposing Precautions

- Request the qualified companies to handle the industrial wastes when disposing of the OLED display modules. Or, when burning them, be sure to observe the environmental and hygienic laws and regulations.

12.6. Other Precautions

- When an OLED display module is operated for a long period of time with a fixed pattern, the fixed pattern may remain as an after image or a slight contrast deviation may occur.
 - If the operation is interrupted and left unused for a while, normal state can be restored.
 - This will not cause a problem in the reliability of the module.
- To protect the OLED display module from performance drops by static electricity rapture, etc., do not touch the following sections whenever possible while handling the OLED display modules.
 - Pins and electrodes
 - Pattern layouts such as the TCP & FPC



- With this OLED display module, the OLED driver is being exposed. Generally speaking, semiconductor elements change their characteristics when light is radiated according to the principle of the solar battery. Consequently, if this OLED driver is exposed to light, malfunctioning may occur.
 - Design the product and installation method so that the OLED driver may be shielded from light in actual usage.
 - Design the product and installation method so that the OLED driver may be shielded from light during the inspection processes.
- Although this OLED display module stores the operation state data by the commands and the indication data, when excessive external noise, etc. enters into the module, the internal status may be changed. Therefore, it is necessary to take appropriate measures to suppress noise generation or to protect from influences of noise on the system design.
- We recommend that you construct its software to make periodical refreshment of the operation statuses (re-setting of the commands and re-transference of the display data), to cope with catastrophic noise.
- Resistors, capacitors, and other passive components will have different appearance and color caused by the different supplier.
- Crystalfontz has the right to upgrade and modify the product function.
- The limitation of FPC bending:

