



OLED DISPLAY MODULE DATASHEET



Datasheet Release Date 2021-07-22
for
CFAL32128A0-0171B-WC

Crystalfontz America, Inc.

12412 East Saltese Avenue
Spokane Valley, WA 99216-0357
Phone: 888-206-9720
Fax: 509-892-1203

Email: support@crystalfontz.com
URL: <https://www.crystalfontz.com>



CONTENTS

1. General Information	3
2. Module Description	4
3. Features	4
4. Mechanical Data	4
5. Mechanical Drawing.....	5
6. Schematic.....	6
7. Interface Pin Function	7
8. Absolute Maximum Ratings	8
9. Optical Characteristics	8
10. Electrical Characteristics.....	8
11. Touch Implementation Notes	9
12. Interface Data Diagrams	9
12.1. 4-Wire SPI.....	9
12.2. I2C	9
13. Power ON and OFF Sequences.....	10
13.1. Power ON.....	10
13.1. Power OFF.....	11
14. OLED Module Precautions.....	12
14.1. Modules.....	12
14.2. Handling Precautions	12
14.3. Storage Precautions.....	13
14.4. Designing Precautions.....	13
14.5. Disposing Precautions.....	13
14.6. Other Precautions	13



1. General Information

Datasheet Revision History

Datasheet Release: 2021-07-22
Datasheet for the CFAL32128A0-0171B-WC OLED graphic display module.

Product Change Notifications

You can check for or subscribe to [Part Change Notices](#) for this display module on our website.

Variations

Slight variations between lots are normal (e.g., contrast, color, or intensity).

Volatility

This display module has volatile memory.

Disclaimer

Certain applications using Crystalfontz America, Inc. products may involve potential risks of death, personal injury, or severe property or environmental damage ("Critical Applications"). CRYSTALFONTZ AMERICA, INC. PRODUCTS ARE NOT DESIGNED, INTENDED, AUTHORIZED, OR WARRANTED TO BE SUITABLE FOR USE IN LIFE-SUPPORT APPLICATIONS, DEVICES OR SYSTEMS OR OTHER CRITICAL APPLICATIONS. Inclusion of Crystalfontz America, Inc. products in such applications is understood to be fully at the risk of the customer. In order to minimize risks associated with customer applications, adequate design and operating safeguards should be provided by the customer to minimize inherent or procedural hazard. Please contact us if you have any questions concerning potential risk applications.

Crystalfontz America, Inc. assumes no liability for applications assistance, customer product design, software performance, or infringements of patents or services described herein. Nor does Crystalfontz America, Inc. warrant or represent that any license, either express or implied, is granted under any patent right, copyright, or other intellectual property right of Crystalfontz America, Inc. covering or relating to any combination, machine, or process in which our products or services might be or are used.

All specifications in datasheets on our website are, to the best of our knowledge, accurate but not guaranteed. Corrections to specifications are made as any inaccuracies are discovered.

Company and product names mentioned in this publication are trademarks or registered trademarks of their respective owners.

Copyright © 2021 by Crystalfontz America, Inc., 12412 East Saltese Avenue, Spokane Valley, WA 99216 U.S.A.



2. Module Description

This is a white monochrome OLED display module that supports 4-key touch plus up and down swipe detection. This display includes in-cell capacitive touch detection. This display has a built in Solomon Systech SSD7317 controller. Please see the [Solomon Systech SSD7317 LCD Controller Datasheet](#) for further reference.

Additional resources including 3D models, the most up-to-date datasheet, and sample code can be found on the product page for this part: crystalfontz.com/product/cfal32128a00171bwc

3. Features

- 32*128 Dot Matrix
- Built-in Controller: SSD7317 (or equivalent)
- +3V Power Supply
- Polarized
- 1/32 Duty
- 4 key touch, plus 2 out-cell
- Interface: SPI, I2C

4. Mechanical Data

Item	Specification (mm)	Specification (inch, reference)
Overall Size (Including tail)	15.75 (W) x 65.5 (H) x 2.0 (D)	0.620 (W) x 2.579 (H) x 0.079 (D)
Display Size	15.75 (W) x 50.5 (H) x 2.0 (D)	0.620 (W) x 1.99 (H) x 0.079 (D)
Active Area	10.54 (W) x 42.22 (H)	0.415 (W) x 1.662 (H)
Pixel Size	0.27 (W) x 0.27(H)	0.011 (W) x 0.011 (H)
Pixel Pitch	0.33 (W) x 0.33 (H)	0.013 (W) x 0.013 (H)
Weight (Typical)	3.4 gram	0.12 ounces

5. Mechanical Drawing

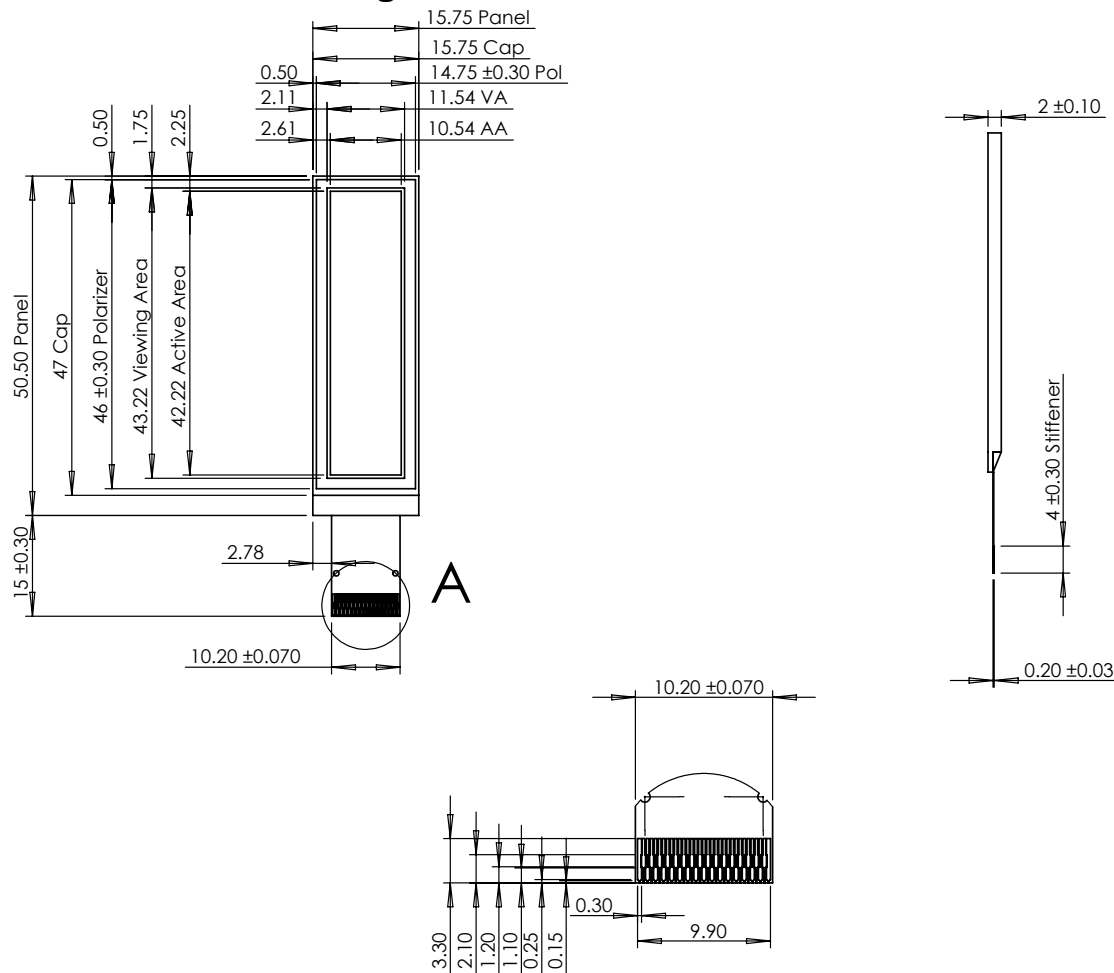

DETAIL A

SCALE 2 : 1

Units: millimeters
Tolerance: ±0.2



PIN No.	Symbol
1	NC (GND)
2	RXT1
3-6	RX0-RX3
7	VCI
8	VSS
9	VCC
10	VCOMH
11	VSL
12	VLSS
13	DCDCENO
14	DCDCENI
15	VDD
16	FR
17	DCS#
18	TCS#
19	RES#
20	TRES#
21	D/C#
22	IRQ
23-25	TD0-TD2
26-28	D0-D2
29	BS1
30	BS3
31	IREF
32	RXT2
33	NC (GND)

6. Schematic

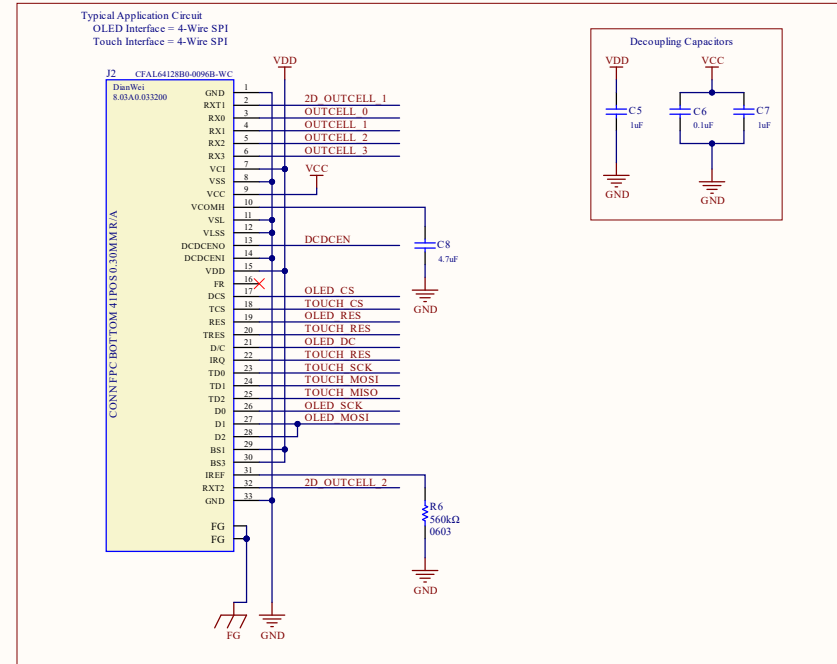
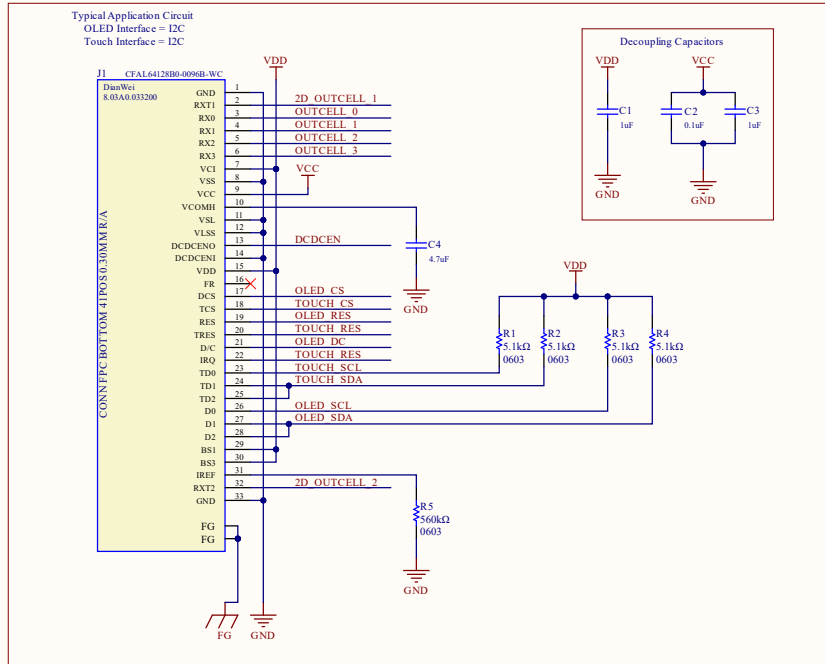

Company	Crystalfontz America, Inc.	Copyright © 2020
		Crystalfontz America, Inc.
Typical Application Circuit with ZIF Connector		
Page 1 / 1 : Full Schematic		
PCB NUMBER	PCB REVISION:	Size: B
In Cell	N/A	
File: In Cell Typical Application.SchDoc		



7. Interface Pin Function

PIN No.	Symbol	Function																				
1	NC (GND)	Reserved.																				
2	RXT1	2D Out-cell 1																				
3-6	RX0-RX3	Connect to external touch keys for out-cell touch																				
7	V _{Cl}	Power supply for touch analog driving. Connect to external source. Must be greater than or equal to V _{DD} .																				
8	V _{SS}	Ground. Connect to external ground.																				
9	V _{CC}	Power Supply for Display. Most positive voltage. Connect to external source.																				
10	V _{COMH}	Voltage output high level for COM signals. Connect capacitor (typ. 4.7μF) between this pin and GND.																				
11	V _{SL}	Segment voltage reference pin. When external V _{SL} is not used, connect externally to V _{LSS} . When external V _{SL} is used, connect with resistor and diode to ground (see controller datasheet).																				
12	V _{LSS}	Analog Ground pin. Connect externally to V _{SS} .																				
13	DCDCENO	Enable output pin for external DCDC circuit. NC if not used.																				
14	DCDCENI	Enable input pin for external DCDC circuit. Tie low if not used.																				
15	V _{DD}	Power supply for Logic. Connect to external source.																				
16	FR	Frame Frequency Triggering signal. This pin is for testing. Leave open when not in use.																				
17	DCS#	Display chip select. The chip is enabled for MCU communication when DCS# is pulled low																				
18	TCS#	Touch chip select. The chip is enabled for MCU communication when TCS# is pulled low																				
19	RES#	Display power reset. When the pin is low, the chip is initialized.																				
20	TRES#	Touch power reset. When the pin is low, the chip is initialized.																				
21	D/C#	Data/Command control pin. In SPI mode when this pin is high, the data at SDI will be interpreted as data; when the pin is low, data will be interpreted as a command. In I2C mode this pin acts as SA0 for slave address selection.																				
22	IRQ	Interrupt signal for touch reporting																				
23-25	TD0-TD2	Serial Data Input/Output and clock for Touch In SPI mode TD2 serves as SDOOUT, TD1 serves as SDIN, and TD0 serves as the serial clock SCLK. In I2C mode TD2 and TD1 should be tied together and serve as SDA and TD0 is the serial clock SCL. External pull up resistors (typ. 5.1kΩ) required.																				
26-28	D0-D2	Serial Data Input/Output and clock for Display In SPI mode D2 and D1 should be tied together to serve as SDIN, and D0 serves as the serial clock SCLK. In I2C mode D2 and D1 should be tied together and serve as SDA and D0 is the serial clock SCL. External pull up resistors (typ. 5.1kΩ) required.																				
29	BS1	MCU Interface Selection <table border="1"> <thead> <tr> <th>BS3</th> <th>BS1</th> <th>Touch</th> <th>Display</th> </tr> </thead> <tbody> <tr> <td>0</td> <td>0</td> <td>4-wire SPI</td> <td>4-wire SPI</td> </tr> <tr> <td>0</td> <td>1</td> <td>4-wire SPI</td> <td>I2C</td> </tr> <tr> <td>1</td> <td>0</td> <td>I2C</td> <td>4-wire SPI</td> </tr> <tr> <td>1</td> <td>1</td> <td>I2C</td> <td>I2C</td> </tr> </tbody> </table>	BS3	BS1	Touch	Display	0	0	4-wire SPI	4-wire SPI	0	1	4-wire SPI	I2C	1	0	I2C	4-wire SPI	1	1	I2C	I2C
BS3	BS1		Touch	Display																		
0	0		4-wire SPI	4-wire SPI																		
0	1		4-wire SPI	I2C																		
1	0	I2C	4-wire SPI																			
1	1	I2C	I2C																			
30	BS3																					
31	I _{REF}	This pin is the brightness adjustment current reference pin. Connect a resistor between this pin and ground (typ. 560kΩ). The current should not exceed 18.75μA.																				
32	RXT2	2D Out-cell 2																				
33	NC (GND)	Reserved.																				



8. Absolute Maximum Ratings

Parameter	Symbol	Min	Max	Unit
Supply Voltage for Logic	V _{DD}	-0.3	4.0	V
Supply Voltage for Display	V _{CC}	0	15	V
Supply Voltage for Touch	V _{CI}	-0.3	4.0	V
Operating Temperature	T _{OP}	-40	+70	°C
Storage Temperature	T _{STG}	-40	+85	°C
Lifetime (250 cd/m ²)		15,000		hours

Note: These are stress ratings only. Extended exposure to the absolute maximum ratings listed above may affect device reliability or cause permanent damage. Functional operation should be restricted to the limits in the Electrical Characteristics table below.

9. Optical Characteristics

Item	Symbol	Min	Typ	Max	Unit
Brightness	L _{br}	100	120	-	Cd/m ²
C.I.E. 1931 (White)	(x) (y)	0.23 0.26	0.27 0.30	0.31 0.34	
Dark Room Contrast	CR		>10,000:1		
Viewing Angle			Free		

10. Electrical Characteristics

Item	Symbol	Condition	Min	Typ	Max	Unit
Supply Voltage for Logic	V _{DD}		1.65	3.0	3.5	V
Supply Voltage for Touch	V _{CI}		3.0	-	3.5	V
Supply Voltage for Display	V _{CC}		11.5	12	12.5	V
High-level Input	V _{IH}		0.8*V _{DD}	-	V _{DD}	V
Low-level Input	V _{IL}		0	-	0.2*V _{DD}	V
High-level Output	V _{OH}	I _{OUT} =100μA, 3.3MHz	0.8*V _{DD}	-	V _{DD}	V
Low-level Output	V _{OL}	I _{OUT} =100μA, 3.3MHz	0	-	0.2*V _{DD}	V
Operating Current for V _{CI} +V _{DD}	I _{CIDD}		-	1.6	2.4	mA
Operating Current for V _{CC}	I _{CC}	30% display on	-	4.8	6.0	mA
		50% display on	-	7.8	9.8	mA
		100% display on	-	13.6	17.0	mA
Sleep Mode Current for V _{CI} +V _{DD}	I _{CIDD,sleep}		-	35	55	μA
Sleep Mode Current for V _{CC}	I _{CC,sleep}		-	1	10	μA



11. Touch Implementation Notes

The in-cell touch sensing is extremely sensitive to noise including even the slightest movement of the panel or materials within 3mm of the panel in any direction. **The OLED panel must be firmly fixed in place relative to any conductive items before the touch controller is initialized.** Any movement of the panel in relation to these conductive items, even a fraction of a millimeter, can interfere with touch sensing and require the touch controller be reinitialized. It is recommended to fix a non-conductive insulation plane such as an air gap (min. 3mm) or plastic (min. 5mm) between the module and PCB.

If the out-cell inputs are not being used, disable them following the touch controller initialization to prevent false touch reports. More information is available in the [SSD7317 controller datasheet](#) appendices and shown in the [demo code available on Crystalfontz's Github](#). The demo code also includes examples on touch sensing feature enabling, touch sensitivity configuration, low power modes and more.

12. Interface Data Diagrams

12.1. 4-Wire SPI

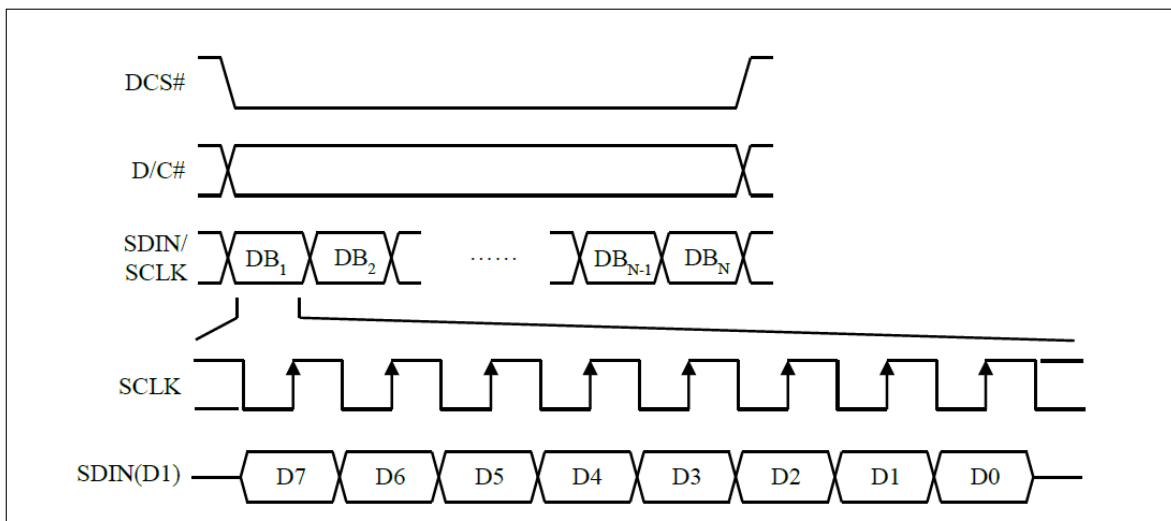

12.2. I2C

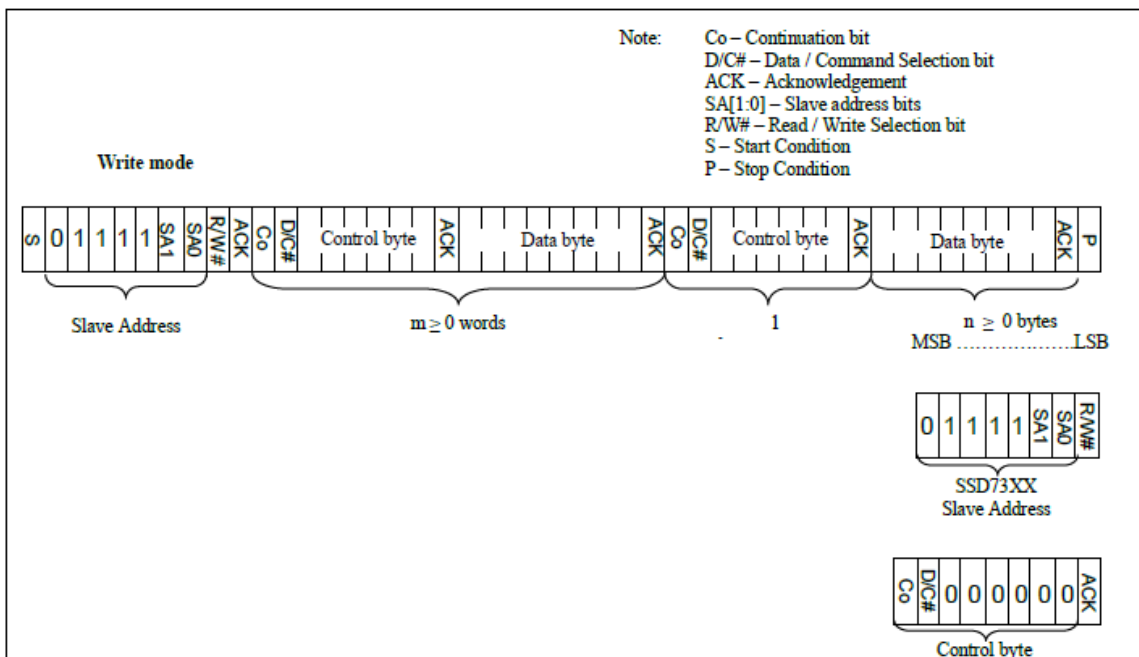



13. Power ON and OFF Sequences

13.1. Power ON

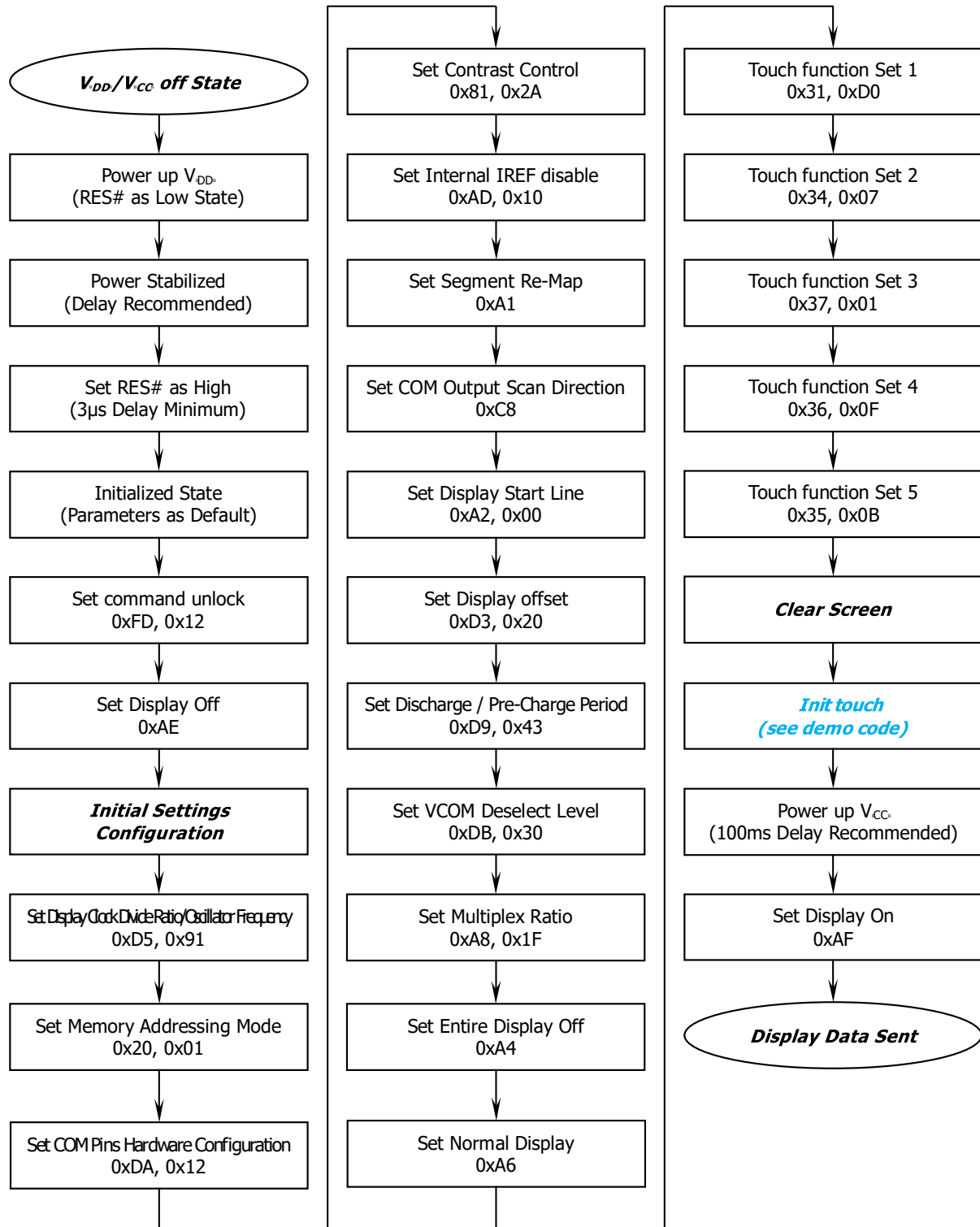

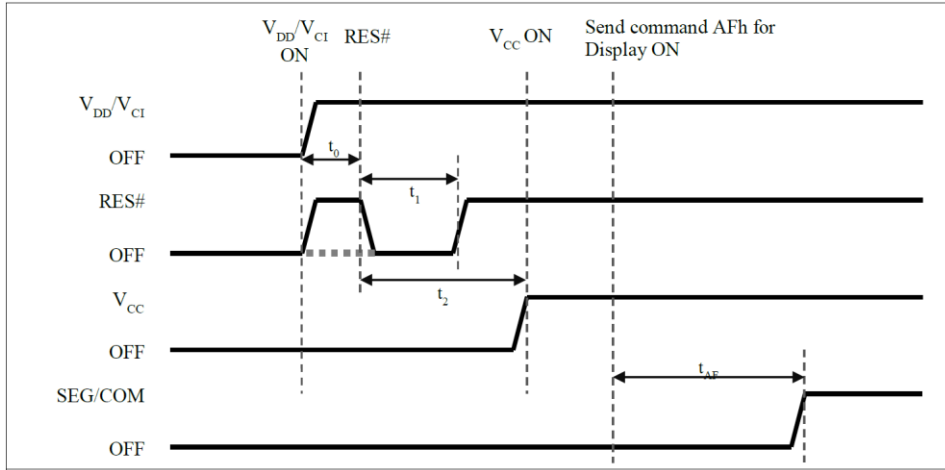

Note: Register values are reset after t_1 .

13.2. Power OFF

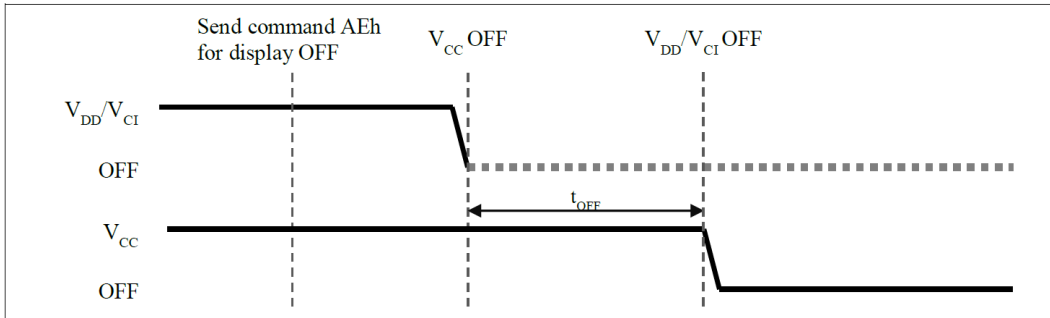
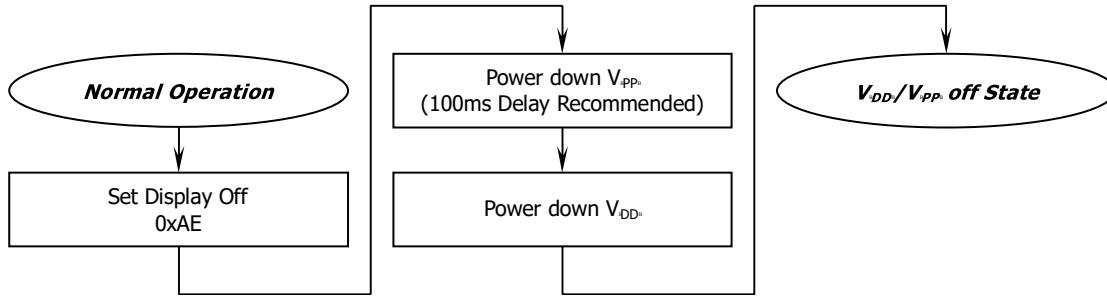

Note: V_{CC} should be floated when OFF.

13.3. Low Power Mode

Enter

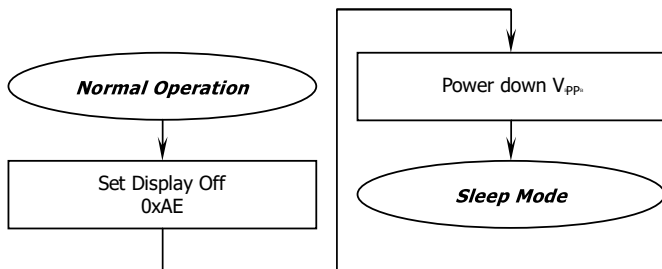

Exit

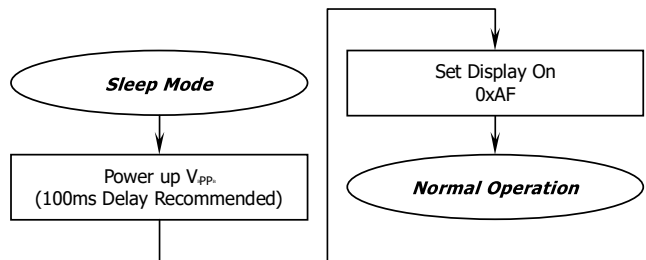



14. OLED Module Precautions

The precautions below should be followed when using OLED modules to help ensure personal safety, module performance, and compliance of environmental regulations.

14.1. Modules

- Avoid applying excessive shocks to module or making any alterations or modifications to it.
- Do not make extra holes on the printed circuit board, modify its shape or change the components of OLED display module.
- Do not disassemble the OLED display module.
- Do not operate the OLED display module above the absolute maximum rating.
- Do not drop, bend or twist the OLED display module.
- Soldering: only to the I/O terminals.
- Store in an anti-static electricity container and clean environment.
- It is common to use the "screen saver" to extend the lifetime of the OLED display module.
 - Do not use the fixed information for long periods of time in real application.
 - Do not use fixed information in OLED panel for long periods of time to extend "screen burn" effect time.
- Crystalfontz has the right to change the passive components. (Resistors, capacitors and other passive components will have different appearance and color caused by the different supplier.)
- Crystalfontz has the right to change the PCB Rev. (In order to satisfy the supplying stability, management optimization and the best product performance, etc., under the premise of not affecting the electrical characteristics and external dimensions, Crystalfontz has the right to modify the version.)

14.2. Handling Precautions

- Since the display panel is made of glass, do not apply mechanical impacts such as dropping from a high position.
- If the display panel is accidentally broken, and the internal organic substance leaks out, be careful not to inhale or touch the organic substance.
- If pressure is applied to the display surface or its neighborhood of the OLED display module, the cell structure may be damaged, so be careful not to apply pressure to these sections.
- The polarizer covering the surface of the OLED display module is soft and can be easily scratched. Please be careful when handling the OLED display module.
- Clean the surface of the polarizer covering the OLED display module if it becomes soiled using following adhesion tape.
 - Scotch Mending Tape No. 810 or an equivalent
 - Never breathe the soiled surface or wipe the surface using a cloth containing solvent such as ethyl alcohol, since the surface of the polarizer will become cloudy.
 - The following liquids/solvents may spoil the polarizer:
 - Water
 - Ketone
 - Aromatic Solvents
- Hold the OLED display module very carefully when placing the OLED display module into the system housing.
- Do not apply excessive stress or pressure to the OLED display module. And, do not over bend the film with electrode pattern layouts. These stresses will influence the display performance. Also, be sure to secure the sufficient rigidity for the outer cases.

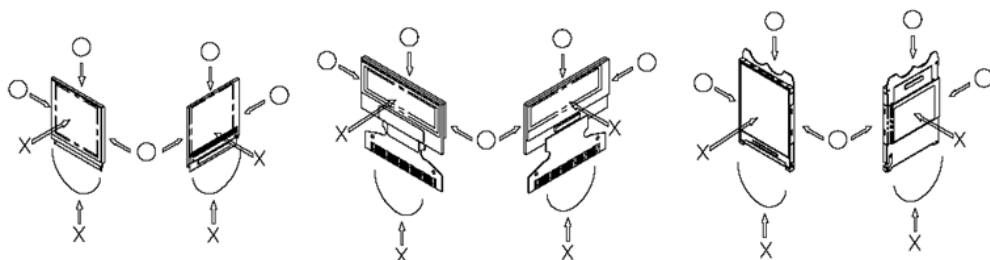



- Do not apply stress to the LSI chips and the surrounding molded sections.
- Do not disassemble or modify the OLED display module.
- Do not apply input signals while the logic power is off.
- Pay sufficient attention to the working environments when handling the OLED display module to prevent occurrence of element breakage accidents by static electricity.
 - Be sure to make human body grounding when handling OLED display modules.
 - Be sure to ground tools to use for assembly such as soldering irons.
 - To suppress generation of static electricity, avoid carrying out assembly work under dry environments.
 - Protective film is being applied to the surface of the display panel of the OLED display module. Be careful since static electricity may be generated when exfoliating the protective film.
- Protection film is being applied to the surface of the display panel and removes the protection film before assembling it. At this time, if the OLED display module has been stored for a long period of time, residue adhesive material of the protection film may remain on the surface of the display panel after the film has been removed. In such a case, remove the residue material by the method discussed above.
- If electric current is applied when the OLED display module is being dewed or when it is placed under high humidity environments, the electrodes may become corroded. If this happens proceed with caution when handling the OLED display module.

14.3. Storage Precautions

- When storing the OLED display modules put them in static electricity preventive bags to avoid exposure to direct sunlight and fluorescent lamps. Also avoid high temperature and high humidity environments and low temperatures (less than 0°C) environments. (We recommend you store these modules in the packaged state when they were shipped from Crystalfontz). Be careful not to let water drops adhere to the packages or bags, and do not let dew gather on them.
- If electric current is applied when water drops are adhering to the surface of the OLED display module the OLED display module may have become dewed. If a dewed OLED display module is placed under high humidity environments it may cause the electrodes to become corroded. If this happens proceed with caution when handling the OLED display module.

14.4. Designing Precautions

- The absolute maximum ratings are the ratings that cannot be exceeded for OLED display module. If these values are exceeded, panel damage may happen.
- To prevent occurrence of malfunctioning by noise pay attention to satisfy the V_{IL} and V_{IH} specifications and, at the same time, to make the signal line cable as short as possible.
- We recommend that you install excess current preventive unit (fuses, etc.) to the power circuit (V_{DD}). (Recommend value: 0.5A)
- Pay sufficient attention to avoid occurrence of mutual noise interference with the neighboring devices.
- As for EMI, take necessary measures on the equipment side.
- When fastening the OLED display module, fasten the external plastic housing section.
- If the power supply to the OLED display module is forcibly shut down, by such errors as taking out the main battery while the OLED display panel is in operation, we cannot guarantee the quality of this OLED display module.
 - Connection (contact) to any other potential than the above may lead to rupture of the IC.

14.5. Disposing Precautions

- Request the qualified companies to handle the industrial wastes when disposing of the OLED display modules. Or, when burning them, be sure to observe the environmental and hygienic laws and regulations.

14.6. Other Precautions

- When an OLED display module is operated for a long period of time with a fixed pattern, the fixed pattern may remain as an after image or a slight contrast deviation may occur.
 - If the operation is interrupted and left unused for a while, normal state can be restored.



- This will not cause a problem in the reliability of the module.
- To protect the OLED display module from performance drops by static electricity rapture, etc., do not touch the following sections whenever possible while handling the OLED display modules.
 - Pins and electrodes
 - Pattern layouts such as the TCP & FPC
- With this OLED display module, the OLED driver is being exposed. Generally speaking, semiconductor elements change their characteristics when light is radiated according to the principle of the solar battery. Consequently, if this OLED driver is exposed to light, malfunctioning may occur.
 - Design the product and installation method so that the OLED driver may be shielded from light in actual usage.
 - Design the product and installation method so that the OLED driver may be shielded from light during the inspection processes.
- Although this OLED display module stores the operation state data by the commands and the indication data, when excessive external noise, etc. enters into the module, the internal status may be changed. Therefore, it is necessary to take appropriate measures to suppress noise generation or to protect from influences of noise on the system design.
- We recommend that you construct its software to make periodical refreshment of the operation statuses (re-setting of the commands and re-transference of the display data), to cope with catastrophic noise.
- Resistors, capacitors, and other passive components will have different appearance and color caused by the different supplier.
- Crystalfontz has the right to upgrade and modify the product function.
- The limitation of FPC bending:

